

# **iR3530/iR2230 User's Guide**



# Manuals for the Machine

The manuals for this machine are divided as follows. Please refer to them for detailed information. The manuals supplied with optional equipment are included in the list below. Depending on the system configuration and product purchased, some manuals may not be needed.



Guides with this symbol are printed manuals.



Guides with this symbol are PDF manuals included on the accompanying CD-ROM.

- **Quick Reference for Basic Operation**

For Basic Operations → Basic Features  
For Additional Functions → To Suit Your Needs

- **Basic Information**

- **Basic Operations**
- **Troubleshooting**

- **Copying and Mail Box Instructions**

- **Fax Instructions**

- **Setting Up the Network Connection and Installing the CD-ROM Software**

- **Remote User Interface Instructions**

- **Network Connectivity and Setup Instructions**

- **Network ScanGear Installation and Instructions**

- **PS/PCL/UFR II Printer Instructions**

- **UFR II Printer Instructions**

- **PCL Printer Driver Installation and Instructions**

- **PS Printer Driver Installation and Instructions**

**Easy Operation Guide**



**User's Guide  
(This Document)**



**Reference Guide**



**Copying and Mail Box  
Guide**



**Facsimile Guide**



**Network Quick Start  
Guide**



**Remote UI Guide**



**Network Guide**



**Network ScanGear  
User's Guide**



**PS/PCL/UFR II Printer  
Guide**



**UFR II Printer Guide**



**PCL Driver Guide**



**PS Driver Guide**



- **Mac OS X PS Printer Driver Installation and Instructions**
- **UFR II Printer Driver Installation and Instructions**
- **Mac OS X UFR II Printer Driver Installation and Instructions**
- **Fax Driver Installation and Instructions**

**Mac PS Driver Guide**



**UFR II Driver Guide**



**Mac UFR II Driver Guide**



**Fax Driver Guide**



- 
- To view the manual in PDF format, Adobe Reader/Adobe Acrobat Reader is required. If Adobe Reader/Adobe Acrobat Reader is not installed on your system, please download it from the Adobe Systems Incorporated website.
  - Considerable effort has been made to ensure that this manual is free of inaccuracies and omissions. However, as we are constantly improving our products, if you need an exact specification, please contact Canon.

# Contents

---

<b>Preface</b> .....	<b>vi</b>
<b>How To Use This Manual</b> .....	<b>vi</b>
Symbols Used in This Manual .....	vi
<b>Legal Notices</b> .....	<b>vii</b>
CE .....	vii
Laser Safety .....	vii
Additional Information .....	viii
International ENERGY STAR Program .....	ix
WEEE Directive .....	ix
EMC Directive .....	ix
R&TTE Directive .....	x
Super G3 .....	x
Abbreviations Used in This Manual .....	x
Trademarks .....	xi
Copyright .....	xi
Disclaimers .....	xi
Legal Limitations on the Usage of Your Product and the Use of Images .....	xii
<b>▲ Important Safety Instructions</b> .....	<b>xiii</b>
Installation .....	xiii
Power Supply .....	xiv
Handling .....	xv
Maintenance and Inspections .....	xviii
Consumables .....	xix
Other Warnings .....	xix
<b>About the Instruction Manual CD-ROM</b> .....	<b>xx</b>
Contents of Instruction Manual CD-ROM .....	xx
Instruction Manual CD-ROM .....	xx
Super G3 FAX Board CD-ROM .....	xx
<b>User Manual CD-ROM Menu</b> .....	<b>xxi</b>
System Requirements .....	xxi
Using The CD-ROM Menu .....	xxii
<b>Periodic Inspection of the Breaker</b> .....	<b>xxiii</b>
Checking the Breaker .....	xxiii

## Chapter 1 Before You Start Using This Machine

---

<b>Installation Location and Handling</b> .....	<b>1-2</b>
Installation Precautions .....	1-2
Avoid Installing the Machine in the Following Locations .....	1-2
Select a Safe Power Supply .....	1-4
Provide Adequate Installation Space .....	1-6
Moving the Machine .....	1-7
Handling Precautions .....	1-7
<b>What This Machine Can Do</b> .....	<b>1-10</b>
<b>System Configuration and Parts</b> .....	<b>1-13</b>

---

Optional Equipment . . . . .	1-13
External View and Internal View . . . . .	1-14
Control Panel Parts . . . . .	1-15
Touch Panel Display . . . . .	1-16
<b>Main Power and Control Panel Power . . . . .</b>	<b>1-18</b>
How to Turn ON the Main Power . . . . .	1-18
<b>Things You Must Do Before Using This Machine . . . . .</b>	<b>1-20</b>
Selecting the Type of Telephone Line . . . . .	1-20
Setting the Current Date and Time . . . . .	1-22
Registering This Machine's Fax Number . . . . .	1-25
Registering Sender Names . . . . .	1-26
Registering the Unit's Name . . . . .	1-28
<b>Displaying a Help Screen . . . . .</b>	<b>1-29</b>

## **Chapter 2 Routine Maintenance**

---

Loading Paper . . . . .	2-2
Replacing the Toner Cartridge . . . . .	2-5

## **Chapter 3 Troubleshooting**

---

Clearing Paper Jams . . . . .	3-2
List of Error Messages . . . . .	3-6
List of Error Codes without Messages . . . . .	3-6

## **Chapter 4 Appendix**

---

Multifunctional Operations . . . . .	4-2
Available Paper Stock . . . . .	4-4
Check Sheet for the Periodic Inspection of the Breaker . . . . .	4-6

# Preface

Thank you for purchasing the Canon iR3530/iR2230. Please read this manual thoroughly before operating the machine in order to familiarize yourself with its capabilities, and to make the most of its many functions. After reading this manual, store it in a safe place for future reference.

This paper manual contains the things you must read before using this machine and basic operations. For the further details of the operations, please refer to the attached CD-ROM manual.

## How To Use This Manual

---

### Symbols Used in This Manual

The following symbols are used in this manual to explain procedures, restrictions, handling precautions, and instructions that should be observed for safety.



#### **WARNING**

Indicates a warning concerning operations that may lead to death or injury to persons if not performed correctly. In order to use the machine safely, always pay attention to these warnings.



#### **CAUTION**

Indicates a caution concerning operations that may lead to injury to persons, or damage to property if not performed correctly. In order to use the machine safely, always pay attention to these cautions.



#### **IMPORTANT**

Indicates operational requirements and restrictions. Be sure to read these items carefully in order to operate the machine correctly, and to avoid damage to the machine.



#### **NOTE**

Indicates a clarification of an operation, or contains additional explanations for a procedure. Reading these notes is highly recommended.

# Legal Notices

---

**CE**



This CE Marking shows compliance of this equipment with Directive 73/23/EEC and Directive 89/336/EEC both as amended by Directive 93/68/EEC.

## Laser Safety

This product is certified as a Class I laser product under IEC60825-1:1993 and EN60825-1:1994. This means that the product does not produce hazardous laser radiation.

Since radiation emitted inside the product is completely confined within protective housings and external covers, the laser beam cannot escape from the machine during any phase of user operation. Do not remove protective housings or external covers, except as directed by the equipment's Reference Guide.



## International ENERGY STAR Program



As an ENERGY STAR® Partner, Canon Inc. has determined that this machine meets the ENERGY STAR® Program for energy efficiency.

The International ENERGY STAR® Office Equipment Program is an international program that promotes energy saving through the use of computers and other office equipment. The program backs the development and dissemination of products with functions that effectively reduce energy consumption. It is an open system in which business proprietors can participate voluntarily. The targeted products are office equipment, such as computers, displays, printers, facsimiles, and copiers. The standards and logos are uniform among participating nations.

## WEEE Directive



European Union (and EEA) only.

This symbol indicates that this product is not to be disposed of with your household waste, according to the WEEE Directive (2002/96/EC) and your national law. This product should be handed over to a designated collection point, e.g., on an authorized one-for-one basis when you buy a new similar product or to an authorized collection site for recycling waste electrical and electronic equipment (EEE). Improper handling of this type of waste could have a possible negative impact on the environment and human health due to potentially hazardous substances that are generally associated with EEE. At the same time, your cooperation in the correct disposal of this product will contribute to the effective usage of natural resources. For more information about where you can drop off your waste equipment for recycling, please contact your local city office, waste authority, approved WEEE scheme or your household waste disposal service. For more information regarding return and recycling of WEEE products, please visit [www.canon-europe.com/environment](http://www.canon-europe.com/environment).

(EEA: Norway, Iceland and Liechtenstein)

## EMC Directive

This equipment conforms with the essential requirements of EC Directive 89/336/EEC.

We declare that this product conforms with the EMC requirements of EC Directive 89/336/EEC at nominal mains input 230V, 50Hz although the rated input of the product is 220V-240V, 50/60Hz.

- Use of shielded cable is necessary to comply with the technical requirements of EMC Directive.

## R&TTE Directive



This equipment (F143300) conforms with the essential requirements of EC Directive 1999/5/EC and is usable in EU.

We declare that this product conforms with the EMC requirements of EC Directive 1999/5/EC at nominal mains input 230 V, 50 Hz although the rated input of the product is 220 V-240 V, 50/60Hz.

Use of shielded cable is necessary to comply with the technical requirements of EMC Directive.

If you move to another EU country and are experiencing trouble please call the Canon Help Desk.

(For Europe Only)  
Canon Inc./Canon Europa N.V.

## Super G3



Super G3 is a phrase used to describe the new generation of fax machines that use ITU-T V.34 standard 33.6 Kbps\* modems. Super G3 High Speed Fax machines allow transmission times of approximately 3 seconds\* per page which results in reduced telephone line charges.

\* Approximately 3 seconds per page fax transmission time based on CCITT/ITU-T No.1 Chart, (JBIG, Standard Mode) at 33.6 Kbps modem speed. The Public Switched Telephone Network (PSTN) currently supports 28.8 Kbps modem speeds or slower, depending on telephone line conditions.

## Abbreviations Used in This Manual

In this manual, product names and model names are abbreviated as follows:

Microsoft® Windows® 98 operating system:	Windows 98
Microsoft® Windows® Millennium Edition operating system:	Windows Me
Microsoft® Windows NT® operating system:	Windows NT
Microsoft® Windows® 2000 operating system:	Windows 2000
Microsoft® Windows® XP operating system:	Windows XP
Microsoft® Windows Server™ 2003 operating system:	Windows Server 2003
Microsoft® Windows® operating system:	Windows

## Trademarks

Canon, the Canon logo and iR are trademarks of Canon Inc.

Adobe, Adobe Acrobat, PostScript, and PostScript 3 are trademarks of Adobe Systems Incorporated.

Macintosh and Mac OS are trademarks of Apple Computer, Inc.

Microsoft, Windows, and Windows NT are registered trademarks of Microsoft Corporation in the United States and other countries.

Windows Server is a trademark of Microsoft Corporation in the United States and other countries.

Other product and company names herein may be the trademarks of their respective owners.

## Copyright

Copyright 2005 by Canon Inc. All rights reserved.

No part of this publication may be reproduced or transmitted in any form or by any means, electronic or mechanical, including photocopying and recording, or by any information storage or retrieval system without the prior written permission of Canon Inc.

## Disclaimers

The information in this document is subject to change without notice.

CANON INC. MAKES NO WARRANTY OF ANY KIND WITH REGARD TO THIS MATERIAL, EITHER EXPRESS OR IMPLIED, EXCEPT AS PROVIDED HEREIN, INCLUDING WITHOUT LIMITATION, THEREOF, WARRANTIES AS TO MARKETABILITY, MERCHANTABILITY, FITNESS FOR A PARTICULAR PURPOSE OF USE OR AGAINST INFRINGEMENT OF ANY PATENT. CANON INC. SHALL NOT BE LIABLE FOR ANY DIRECT, INCIDENTAL, OR CONSEQUENTIAL DAMAGES OF ANY NATURE, OR LOSSES OR EXPENSES RESULTING FROM THE USE OF THIS MATERIAL.

## Legal Limitations on the Usage of Your Product and the Use of Images

Using your product to scan, print or otherwise reproduce certain documents, and the use of such images as scanned, printed or otherwise reproduced by your product, may be prohibited by law and may result in criminal and/or civil liability. A non-exhaustive list of these documents is set forth below. This list is intended to be a guide only. If you are uncertain about the legality of using your product to scan, print or otherwise reproduce any particular document, and/or of the use of the images scanned, printed or otherwise reproduced, you should consult in advance with your legal advisor for guidance.

- Paper Money
- Checks or Drafts Issued by Governmental Agencies
- Internal Revenue Stamps (cancelled or uncanceled)
- Money Orders
- Motor Vehicle Licenses and Certificates of Title
- Bonds or Other Certificates of Indebtedness
- Certificates of Deposit
- Travelers Checks
- Stock Certificates
- Postage Stamps (cancelled or uncanceled)
- Food Stamps
- Copyrighted Works/Works of Art without Permission of Copyright Owner
- Identifying Badges or Insignias
- Passports
- Selective Service or Draft Papers
- Immigration Papers

# Important Safety Instructions

---

Please read these "Important Safety Instructions" thoroughly before operating the machine. As these instructions are intended to prevent injury to the user or other persons or destruction of property, always pay attention to these instructions. Also, since it may result in unexpected accidents or injuries, do not perform any operation unless otherwise specified in the manual. Improper operation or use of this machine could result in personal injury and/or damage requiring extensive repair that may not be covered under your Limited Warranty.

## Installation

### WARNING

- Do not install the machine near alcohol, paint thinner, or other flammable substances. If flammable substances come into contact with electrical parts inside the machine, it may result in a fire or electrical shock.
- Do not place the following items on the machine. If these items come into contact with a high-voltage area inside the machine, it may result in a fire or electrical shock.

If these items are dropped or spilled inside the machine, immediately turn OFF the main power switch, and disconnect the power cord from the power outlet. Then, contact your local authorized Canon dealer.

- Necklaces and other metal objects
- Cups, vases, flowerpots, and other containers filled with water or liquids

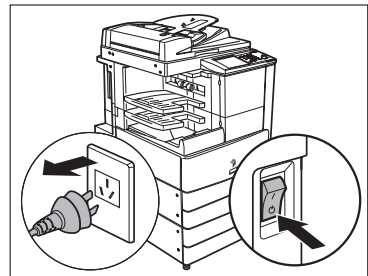

## CAUTION

- Do not install the machine in unstable locations, such as unsteady platforms or inclined floors, or in locations subject to excessive vibrations, as this may cause the machine to fall or tip over, resulting in personal injury.
- Never block the ventilation slots and louvers on the machine. These openings are provided for proper ventilation of working parts inside the machine. Blocking these openings can cause the machine to overheat. Never place the machine on a soft surface, such as a sofa or rug.
- Do not install the machine in the following locations:
  - A damp or dusty location
  - A location near water faucets or water
  - A location exposed to direct sunlight
  - A location subject to high temperatures
  - A location near open flames
- Do not remove the machine's leveling feet after the machine has been installed, as this may cause the machine to fall or tip over, resulting in personal injury.

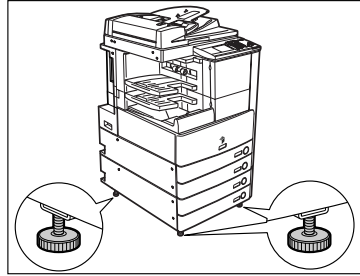

## Power Supply

### WARNING

- Do not damage or modify the power cord. Also, do not place heavy objects on the power cord, or pull on or excessively bend it, as this could cause electrical damage and result in a fire or electrical shock.
- Keep the power cord away from a heat source; failure to do this may cause the power cord coating to melt, resulting in a fire or electrical shock.
- Do not connect or disconnect the power cord with wet hands, as this may result in electrical shock.
- Do not connect the power cord to a multiplug power strip, as this may cause a fire or electrical shock.
- Do not bundle up or tie the power cord in a knot, as this may result in a fire or electrical shock.
- Insert the power plug completely into the power outlet, as failure to do so may result in a fire or electrical shock.

- Do not use power cords other than the power cord provided, as this may result in a fire or electrical shock.
- As a general rule, do not use extension cords. Using an extension cord may result in a fire or electrical shock. If an extension cord must be used, however, use one rated for voltages of 220-240 V AC, 50/60 Hz and over, untie the cord binding, and insert the power plug completely into the extension cord outlet to ensure a firm connection between the power cord and the extension cord.

### CAUTION

- Do not use power supplies with voltages other than those specified herein, as this may result in a fire or electrical shock.
- Always grasp the power plug when disconnecting the power cord. Pulling on the power cord may expose or snap the core wire, or otherwise damage the power cord. If the power cord is damaged, this could cause current to leak, resulting in a fire or electrical shock.
- Leave sufficient space around the power plug so that it can be unplugged easily. If objects are placed around the power plug, you will be unable to unplug it in an emergency.

## Handling

### WARNING

- Do not attempt to disassemble or modify the machine. There are high-temperature and high-voltage components inside the machine which may result in a fire or electrical shock.
- If the machine makes strange noises, or gives off smoke, heat, or strange smells, immediately turn OFF the main power switch, and disconnect the power cord from the power outlet. Then, contact your local authorized Canon dealer. Continued use of the machine in this condition may result in a fire or electrical shock.
- Do not use highly flammable sprays near the machine. If gas from these sprays comes into contact with the electrical components inside the machine, it may result in a fire or electrical shock.
- To avoid damage to the power cord and creating a fire hazard, always turn OFF the main power switch, and unplug the interface cable when moving the machine. Otherwise, the power cord or interface cable may be damaged, resulting in a fire or electrical shock.
- Do not drop paper clips, staples, or other metal objects inside the machine. Also, do not spill water, liquids, or flammable substances (alcohol, benzene, paint thinner, etc.) inside the machine. If these items come into contact with a high-voltage area inside the machine, it may result in a fire or electrical shock. If these items are dropped or spilled inside the machine, immediately turn OFF the main power switch, and disconnect the power cord from the power outlet. Then, contact your local authorized Canon dealer.

## CAUTION

- Do not place heavy (2 kg or more) objects on the machine, as they may tip over or fall resulting in personal injury.
- Close the feeder/platen cover gently to avoid catching your hands, as this may result in personal injury.
- Do not press down hard on the feeder/platen cover when using the platen glass to make copies of thick books. Doing so may damage the platen glass and result in personal injury.
- Do not touch the finisher while the machine is printing, as this may result in personal injury.
- Even if the machine is not operating, do not touch the rollers in the paper output areas, such as the one on the left side of the machine. The rollers may suddenly move to output prints, and catch your hands or clothing, which may result in personal injury.
- If a finisher is attached to the machine, do not place your hand in the part of the tray where stapling is performed or where the rollers are located, as this may result in personal injury.

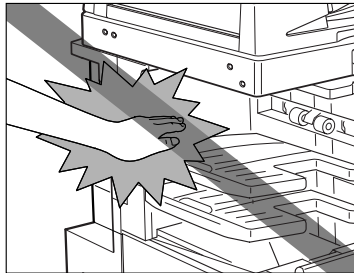
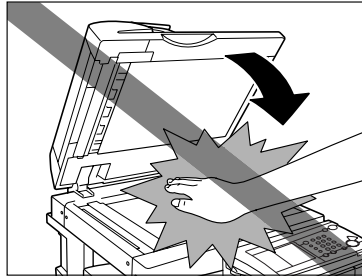

Finisher-S1

- The laser beam can be harmful to human bodies. Since radiation emitted inside the product is completely confined within protective housings and external covers, the laser beam cannot escape from the machine during any phase of user operation. Read the following remarks and instructions for safety.

- Never open covers other than those instructed in this manual.
- Do not remove the following caution labels which are attached to the machine.

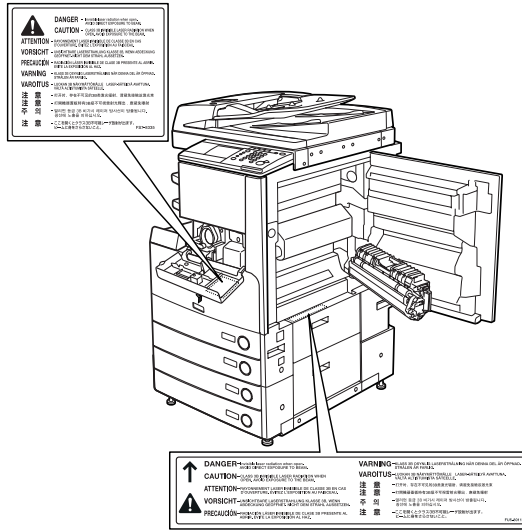

- This product is certified as a Class I laser product under IEC60825-1:1993.
- If the laser beam escapes from the machine, exposure may cause serious damage to your eyes.
- Turn OFF the control panel power switch for safety when the machine will not be used for a long period of time, such as overnight. Also, turn OFF the main power switch, and disconnect the power cord for safety when the machine will not be used for an extended period of time, such as during consecutive holidays.

# Maintenance and Inspections

## WARNING

- When cleaning the machine, first turn OFF the main power switch, then disconnect the power cord. Failure to observe these steps may result in a fire or electrical shock.
- Disconnect the power cord from the power outlet regularly, and clean the area around the base of the power plug's metal pins and the power outlet with a dry cloth to ensure that all dust and grime is removed. If the power cord is connected for a long period of time in a damp, dusty, or smoky location, dust can build up around the power plug and become damp. This may cause a short circuit and result in a fire.
- Clean the machine using a slightly dampened cloth with a mild detergent mixed with water. Do not use alcohol, benzene, paint thinner, or other flammable substances. Check detergent for flammability prior to use. If flammable substances come into contact with a high-voltage area inside the machine, it may result in a fire or electrical shock.
- There are some areas inside the machine which are subject to high-voltages. When removing jammed paper or when inspecting the inside of the machine, do not allow necklaces, bracelets, or other metal objects to touch the inside of the machine, as this may result in burns or electrical shock.
- Do not burn or throw used toner cartridges into open flames, as this may cause the toner remaining inside the cartridges to ignite, resulting in burns or a fire.

## CAUTION

- The fixing unit and its surroundings inside the machine may become hot during use. When removing jammed paper or when inspecting the inside of the machine, do not touch the fixing unit and its surroundings, as doing so may result in burns or electrical shock.
- When removing jammed paper or replacing the toner cartridge, take care not to allow the toner to come into contact with your hands or clothing, as this will dirty your hands or clothing. If they become dirty, wash them immediately with cold water. Washing them with warm water will set the toner, and make it impossible to remove the toner stains.
- When removing paper which has become jammed inside the machine, remove the jammed paper gently to prevent the toner on the paper from scattering and getting into your eyes or mouth. If the toner gets into your eyes or mouth, wash them immediately with cold water and immediately consult a physician.
- When loading paper or removing jammed originals or paper, take care not to cut your hands on the edges of the originals or paper.
- When removing a used toner cartridge, remove the cartridge carefully to prevent the toner from scattering and getting into your eyes or mouth. If the toner gets into your eyes or mouth, wash them immediately with cold water and immediately consult a physician.

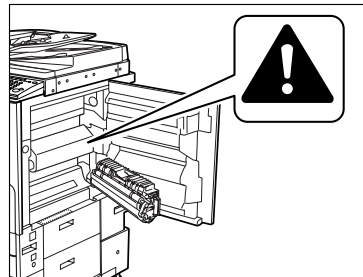

## Consumables

### WARNING

- Do not burn or throw used toner cartridges into open flames, as this may cause the toner remaining inside the cartridges to ignite, resulting in burns or a fire.
- Do not store toner cartridges or copy paper in places exposed to open flames, as this may cause the toner or paper to ignite, resulting in burns or a fire.
- When discarding used toner cartridges, put the cartridges in a bag to prevent the toner remaining inside the cartridges from scattering, and dispose of them in a location away from open flames.

### CAUTION

Keep toner and other consumables out of the reach of small children. If these items are ingested, consult a physician immediately.

## Other Warnings

### WARNING

For cardiac pacemaker users:

This product generates a low level magnetic field. If you use a cardiac pacemaker and feel abnormalities, please move away from the product and consult your doctor.

# About the Instruction Manual CD-ROM

---

## Contents of Instruction Manual CD-ROM

### ***Instruction Manual CD-ROM***

This contains the English, French, Italian, and German versions of the following guides.

#### ■ **Easy Operation Guide**

- **Basic Features**  
Contains the basic operation instructions of the Copy, Mail Box, Fax, Remote UI, and Printer functions.
- **To Suit Your Needs**  
Contains the basic settings of the Additional Functions screen.

#### ■ **Reference Guide**

Contains the basic operation instructions, daily maintenance, and troubleshooting instructions.

#### ■ **Copying and Mail Box Guide**

Contains the Copying and Mail Box function instructions.

#### ■ **Remote UI Guide**

Contains the Remote User Interface instructions.

#### ■ **Network Guide**

Contains the Network Connectivity and setup instructions.

### ***Super G3 FAX Board CD-ROM***

This contains the English, French, Italian, and German versions of the following guides.

#### ■ **Facsimile Guide**

Contains the Facsimile function instructions.

#### **NOTE**

*The Super G3 FAX Board CD-ROM come with the optional Super G3 FAX Board.*

# User Manual CD-ROM Menu

---

The User Manual CD-ROM Menu is software that enables you to select and view PDF Manuals included on the CD-ROM via your computer screen. Follow the instructions below to use the User Manual CD-ROM Menu.

## System Requirements

The User Manual CD-ROM Menu can be used in the following system environments.

	Windows	Macintosh
OS	Windows 98/Me Windows NT (Service Pack 3 or later) Windows 2000 (Service Pack 3 or later) Windows XP (Service Pack 1a) Windows Server 2003	Mac OS 9.x Mac OS X
Memory	The memory required to run the above operating systems	
Computer	A computer that can run the above operating systems	
Display	A resolution of 1024 x 768 pixels or higher	



### IMPORTANT

*Depending on the configuration of your computer, some functions may not operate correctly. If the PDF manual does not open from the CD-ROM Menu, open the PDF file directly from the [uk\_english] or [asia-pacific\_english] folder on the User Manual CD-ROM.*

## Using The CD-ROM Menu

This section describes how to use the CD-ROM Menu. When you insert the User Manual CD-ROM provided into the CD-ROM drive, the Language Selection screen is displayed. Clicking a language on this screen displays the following menu. (The sample screen shot shown here is for Windows users.)



### NOTE

*For Macintosh users, double-click the [START] icon to start the CD-ROM Menu. The Language Selection screen is displayed.*



#### ① BROWSE MANUAL

You can read any of the listed guides by clicking on the desired guide. After clicking on the desired guide, Acrobat Reader starts, and the PDF manual is displayed.

#### ② RETURN

Return to the Language Selection menu.

#### ③ EXIT

Exit the CD-ROM menu.

The screen shot shown above may differ from the one you actually see, depending on the machine you are using.

# Periodic Inspection of the Breaker

This machine has a breaker that detects excess current or leakage current. Be sure to test the breaker once or twice a month using the following procedure.

## IMPORTANT

- Make sure that the main power is turned OFF, before inspecting the breaker.
- If a malfunction occurs after an inspection, contact your local authorized Canon dealer.

## Checking the Breaker

### **1** Push the test button with the tip of a ball-point pen, or similar object.

#### IMPORTANT

*Briefly push the test button.*

### **2** Confirm that the breaker lever is switched to the OFF ("○" side) position.

#### IMPORTANT

- Do not use the test button to turn the power ON and OFF.
- If the breaker lever does not switch to the OFF ("○" side) position, repeat step 1.
- If the breaker lever does not switch to the OFF ("○" side) position, despite carrying out the above procedure two or three times, contact your local authorized Canon dealer.

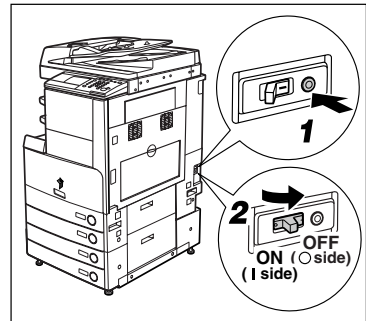

**3** Move the breaker lever to ON ("I" side).

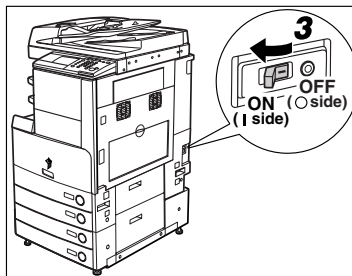

**4** Press the main power switch to the "I" side.

**5** Fill in the check sheet, located on p. 4-6, to document your periodic inspections of the breaker.

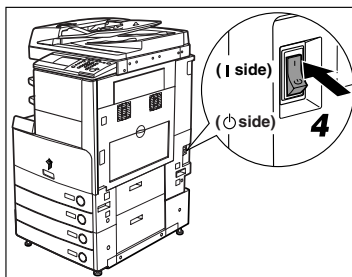

# Before You Start Using This Machine

# 1

## CHAPTER

This chapter describes what you should know before using this machine, such as parts and their functions, and how to turn ON the main power.

---

Installation Location and Handling . . . . .	1-2
Installation Precautions . . . . .	1-2
Handling Precautions . . . . .	1-7
What This Machine Can Do . . . . .	1-10
System Configuration and Parts . . . . .	1-13
Optional Equipment . . . . .	1-13
External View and Internal View . . . . .	1-14
Control Panel Parts . . . . .	1-15
Touch Panel Display . . . . .	1-16
Main Power and Control Panel Power . . . . .	1-18
How to Turn ON the Main Power . . . . .	1-18
Things You Must Do Before Using This Machine . . . . .	1-20
Selecting the Type of Telephone Line . . . . .	1-20
Setting the Current Date and Time . . . . .	1-22
Registering This Machine's Fax Number . . . . .	1-25
Registering Sender Names . . . . .	1-26
Registering the Unit's Name . . . . .	1-28
Displaying a Help Screen . . . . .	1-29

# Installation Location and Handling

This section describes precautions for installation location and handling. We recommend that you read this section prior to using this machine.

## Installation Precautions

### *Avoid Installing the Machine in the Following Locations*

■ **Avoid locations subject to extremes of temperature and humidity, whether low or high.**

For example, avoid installing the machine near water faucets, hot water heaters, humidifiers, air conditioners, heaters, or stoves.

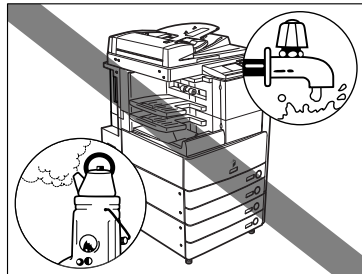

■ **Avoid installing the machine in direct sunlight.**

If this is unavoidable, use curtains to shade the machine. Be sure that the curtains do not block the machine's ventilation slots or louvers, or interfere with the electrical cord or power supply.

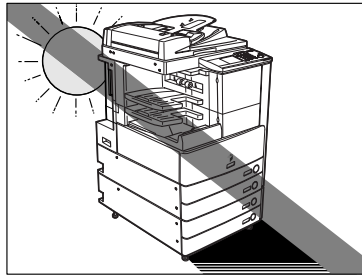

**■ Avoid poorly ventilated locations.**

This machine generates a slight amount of ozone during normal use. Although sensitivity to ozone may vary, this amount is not harmful. Ozone may be more noticeable during extended use or long production runs, especially in poorly ventilated rooms. It is recommended that the room be appropriately ventilated, sufficient to maintain a comfortable working environment, in areas of machine operation.

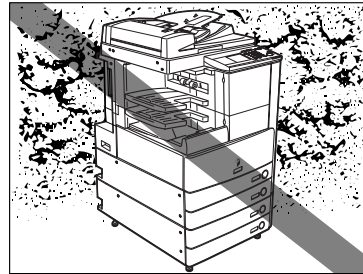
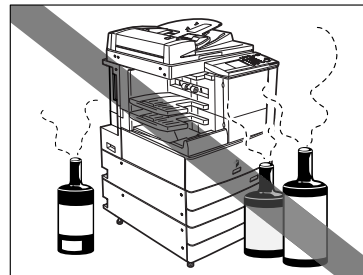
**■ Avoid locations where a considerable amount of dust accumulates.****■ Avoid locations where ammonia gas is emitted.****■ Avoid locations near volatile or flammable materials, such as alcohol or paint thinner.****■ Avoid locations that are subject to vibration.**

For example, avoid installing the machine on unstable floors or stands.

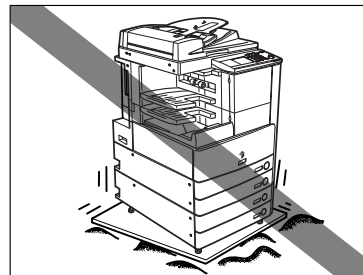

- **Avoid exposing the machine to rapid changes in temperature.**

If the room in which the machine is installed is cold but rapidly heated, water droplets (condensation) may form inside the machine. This may result in a noticeable degradation in the quality of the copied image, the inability to properly scan an original, or the copies having no printed image at all.

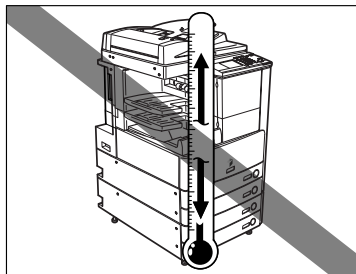

- **Avoid installing the machine near computers or other precision electronic equipment.**

Electrical interference and vibrations generated by the machine during printing can adversely affect the operation of such equipment.

- **Avoid installing the machine near televisions, radios, or similar electronic equipment.**

The machine might interfere with sound and picture signal reception. Insert the power plug into a dedicated power outlet, and maintain as much space as possible between the machine and other electronic equipment.

- **Do not remove the machine's leveling feet.**

Do not remove the machine's leveling feet after the machine has been installed. If you put weight on the front of the machine while the drawers or units within the machine are pulled out, the machine may fall forward. To prevent this from happening, make sure that the machine's leveling feet are in place.

### ***Select a Safe Power Supply***

- **Plug the machine into a 220-240 V AC outlet.**

- **Make sure that the power supply for the machine is safe, and has a steady voltage.**

- **Do not connect other electrical equipment to the same power outlet to which the machine is connected.**

- Do not connect the power cord to a multiplug power strip, as this may cause a fire or electrical shock.
- The power cord may become damaged if it is often stepped on or if heavy objects are placed on it. Continued use of a damaged power cord can lead to an accident, such as a fire or electrical shock.

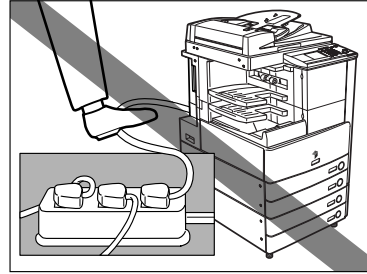

## Provide Adequate Installation Space

- Provide enough space on each side of the machine for unrestricted operation.

No optional equipment is attached.

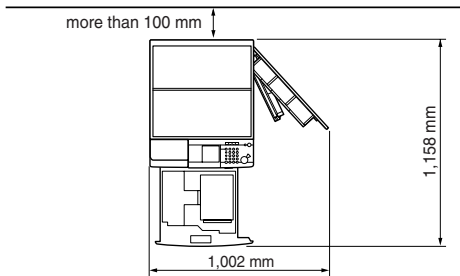

The optional Feeder (DADF-N1) and Finisher-S1 are attached.

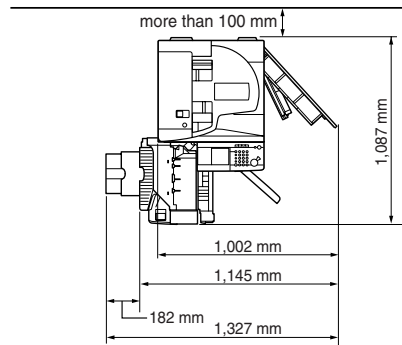

## ***Moving the Machine***

- If you intend to move the machine, contact your local authorized Canon dealer beforehand.

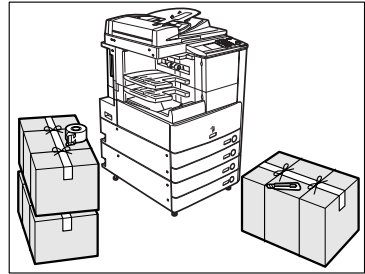

## **Handling Precautions**

- Do not attempt to disassemble or modify the machine.

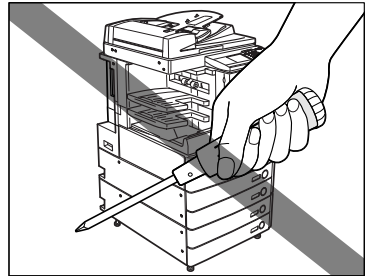

- Some parts inside the machine are subject to high-voltages and temperatures. Take adequate precautions when inspecting the inside of the machine. Do not carry out any inspections not described in this manual.

- Be careful not to spill liquid or drop any foreign objects, such as paper clips or staples inside the machine. If a foreign object comes into contact with electrical parts inside the machine, it might cause a short circuit and result in a fire or electrical shock.

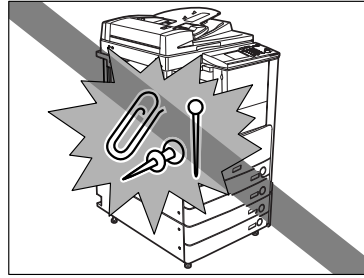

- If there is smoke, or unusual noise, immediately turn the main power switch OFF, disconnect the power cord from the outlet, and call your local authorized Canon dealer. Using the machine in this state may cause a fire or electrical shock. Also, avoid placing objects around the power plug so that the machine can be disconnected whenever necessary.

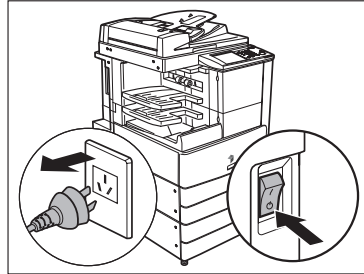

- Do not turn the main power switch OFF or open the front covers while the machine is in operation. This might result in paper jams.
- Do not use flammable sprays, such as spray glue, near the machine. There is a danger of ignition.

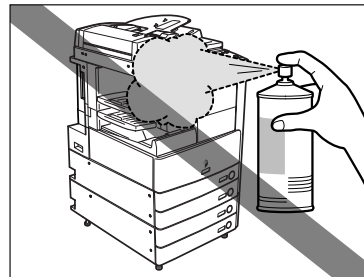

■ This machine generates a slight amount of ozone during normal use. Although sensitivity to ozone may vary, this amount is not harmful. Ozone may be more noticeable during extended use or long production runs, especially in poorly ventilated rooms. It is recommended that the room be appropriately ventilated, sufficient to maintain a comfortable working environment, in areas of machine operation.

■ For safety reasons, turn OFF the control panel power switch of the machine when it will not be used for a long period of time, such as overnight. As an added safety measure, turn OFF the main power switch, and disconnect the power cord when the machine will not be used for an extended period of time, such as during consecutive holidays.

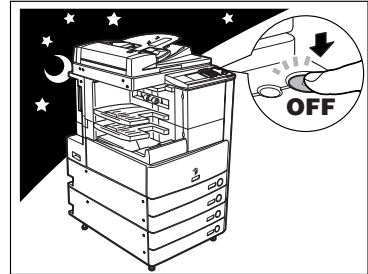

■ Use a telephone cable 3 m long or less.

**! CAUTION**

Canon recommends that data stored on the product's hard disk drive be duplicated or backed up to prevent its loss in the event of failure or other malfunction of the hard disk drive. Neither Canon nor any service provider will be liable for damages for loss of data stored on the product's hard disk drive. (See the terms of the product's Limited Warranty for more details.)

# What This Machine Can Do

**All the elements you will ever need in a digital multitasking machine.**

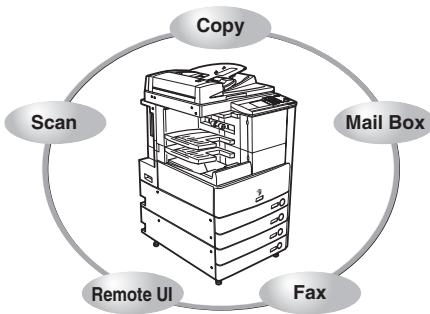

The iR3530/iR2230 incorporates a rich array of input and output features that can greatly enhance your efficiency. Equipped with features that meet the needs of document work in a digitized office, the iR3530/iR2230 represents the ultimate in digital multitasking machines.

## Copying

See the *Copying and Mail Box Guide*

In addition to normal copying functions, convenient new functions, such as "Sample Set" which helps to avoid copy errors, and "Different Size Originals" for copying originals of different sizes together in one copy operation, are provided to increase your productivity.

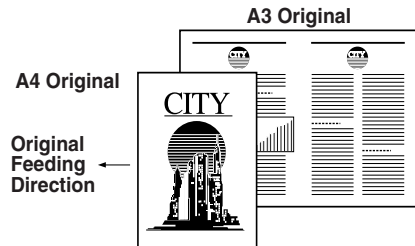

## Mail Box Function (optional)\*

See the *Copying and Mail Box Guide*

The Mail Box function enables you to save image or document data that has been scanned from the scanner unit, or created on a PC to the machine's internal hard disk. The saved data can be printed at a specified time, or merged with separately saved data or data created on a PC for simultaneous processing.

\* The optional iR System Expansion Kit is required.

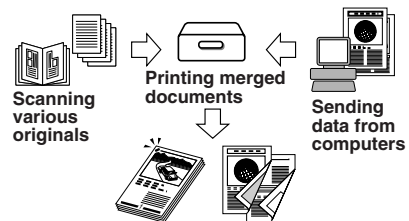

---

**Faxing (optional)\*****See the *Facsimile Guide***

---

In addition to normal facsimile functions, the machine offers you Super G3 compatibility, which enables you to transmit documents at high speeds, greatly reducing transmission costs as compared to conventional facsimile machines. In a mobile environment, you can also receive faxes remotely from the machine outside of the office.

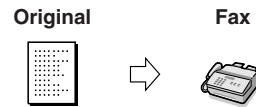

\* The optional iR System Expansion Kit and Super G3 FAX Board are required.

---

**Printing (optional)\* See the *PS/PCL/UFR II Printer Guide* or *UFR II Printer Guide***

---

You can upgrade this machine to a high-speed network printer by installing the optional UFR II Printer Kit. This kit incorporates UFR II (Ultra Fast Rendering II) Technology, which utilizes Canon's original printing algorithm to minimize file processing and achieve maximum performance.

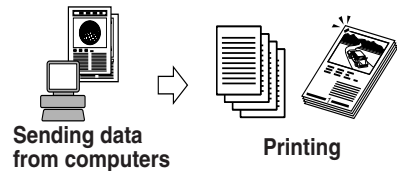

In addition to the capabilities of the UFR II Printer Kit, the optional Printer Kit supports PCL5e/6 emulation printing solutions.

The optional Multi-PDL Printer Kit supports not only UFR II and PCL but also PostScript3 emulation printing solutions, thus is well-suited for users who are using Adobe applications.

\* The optional iR System Expansion Kit and any one of the optional UFR II Printer Kit, Printer Kit , or Multi-PDL Printer Kit are required. Only one printer kit can be installed.

**Using the Remote User Interface (optional)\***

See the *Remote UI Guide*

You can control functions, such as confirming the status of the machine, job operations, and printing instructions for data saved in inboxes, all from your PC's web browser.

\* The optional iR System Expansion Kit is required.

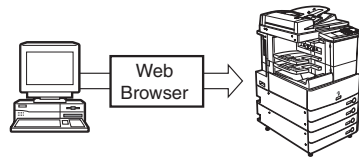

**Scanning (optional)\***

See the *Network ScanGear User's Guide*

Scanning image data into computers is a function that is available if the iR3530/iR2230 is upgraded with printer and network capabilities. You can scan images of up to A3 in size at a resolution of 600 x 600 dpi.

\* The optional iR System Expansion Kit and any one of the optional UFR II Printer Kit, Printer Kit, or Multi-PDL Printer Kit are required.

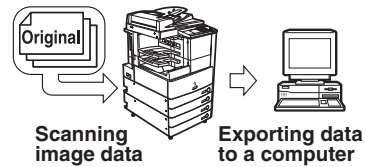

# System Configuration and Parts

## Optional Equipment

1

Before You Start Using This Machine

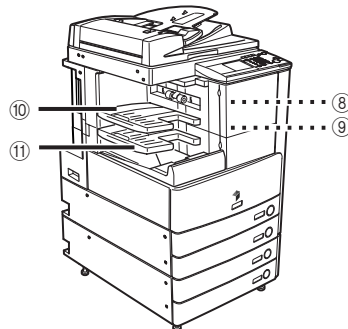
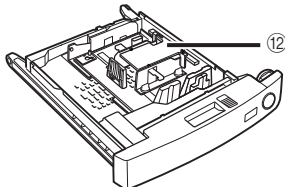
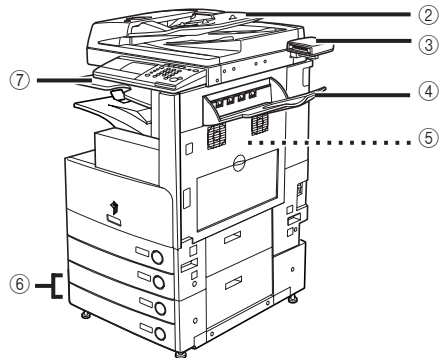
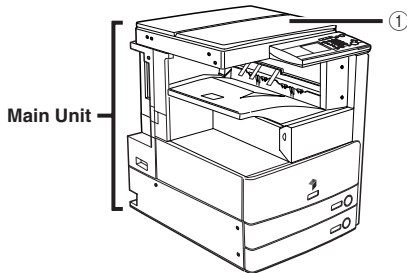

- ① Platen Cover Type H
- ② Feeder (DADF-N1)
- ③ Card Reader-C1
- ④ Copy Tray-J1
- ⑤ 3 Way Unit-A1
- ⑥ Cassette Feeding Unit-Y2
- ⑦ Inner 2 Way Tray-D1
- ⑧ Staple-J1
- ⑨ Puncher Unit-Q1
- ⑩ Additional Finisher Tray-B1

- ⑪ Finisher-S1
- ⑫ Envelope Feeder Attachment-C1

# External View and Internal View

1

Before You Start Using This Machine

- ① Feeder (DADF-N1)
- ② Control Panel
- ③ Main Unit's Right Cover
- ④ Stack Bypass
- ⑤ Main Power Switch
- ⑥ Test Button
- ⑦ Breaker
- ⑧ Paper Drawer's Right Cover
- ⑨ Paper Drawer 2
- ⑩ Paper Drawer 1
- ⑪ Output Tray
- ⑫ Output Tray Guide

The optional Feeder (DADF-N1) and Cassette Feeding Unit-Y2 are attached.

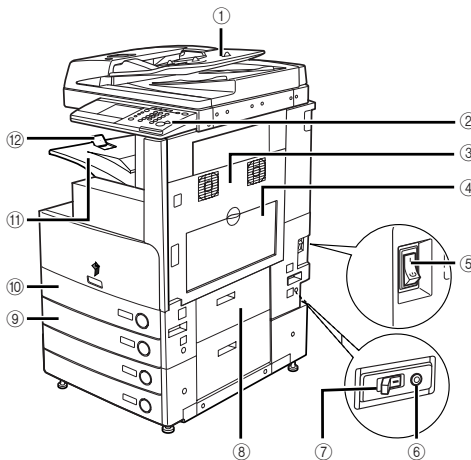

- ⑬ Platen Glass
- ⑭ Fixing Unit's Upper Cover
- ⑮ Duplexing Unit
- ⑯ Toner Supply Port Cover
- ⑰ Toner Cartridge

The optional Feeder (DADF-N1) and Cassette Feeding Unit-Y2 are attached.

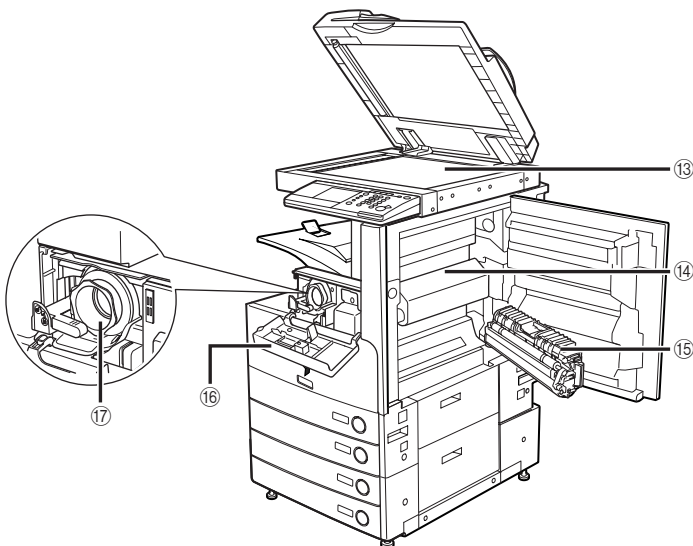

# Control Panel Parts

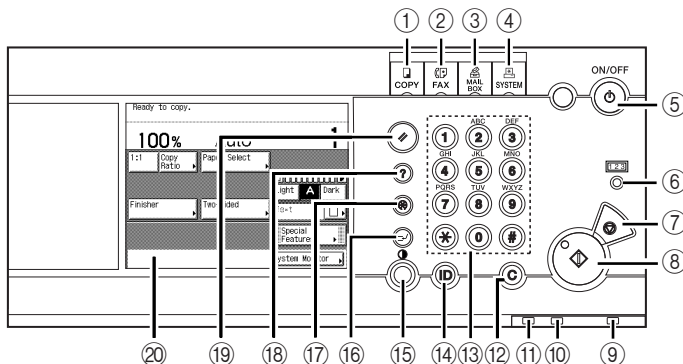

- ① **COPY key**  
Press to use the Copy function. The Copy Basic Features screen appears on the touch panel display.
- ② **FAX key**  
Press to use the Fax function. The Fax Basic Features screen appears on the touch panel display.
- ③ **MAIL BOX key**  
Press to use the Mail Box function. The Inbox Selection screen appears on the touch panel display.
- ④ **SYSTEM key**  
Press when the network scan function is enabled.
- ⑤ **Control Panel Power Switch (Sub Power Supply)**  
Press to turn the control panel ON or OFF. When turned OFF, the machine is in the Sleep mode.
- ⑥ **Counter Check key**  
Press to display the copy and print count total on the touch panel display.
- ⑦ **Stop key**  
Press to stop a job in progress, such as a scan job, copy job, or fax job (scanning only).
- ⑧ **Start key**  
Press to start an operation.
- ⑨ **Main Power Indicator**  
Lights when the main power is turned ON.
- ⑩ **Error Indicator**  
Flashes or lights if there is an error in the machine. When the Error indicator flashes, follow the instructions that appear on the touch panel display. When the Error indicator maintains a steady red light, contact your local authorized Canon dealer.
- ⑪ **Processing/Data Indicator**  
Flashes or blinks green when the machine is performing operations, and maintains a steady green light, when fax data is stored in memory.
- ⑫ **Clear key**  
Press to clear entered values or characters.
- ⑬ **Numeric keys**  
Press to enter numerical values.
- ⑭ **ID key**  
Press when setting or enabling Department ID Management.
- ⑮ **Display Contrast Dial**  
Use to adjust the brightness of the touch panel display.
- ⑯ **Interrupt key**  
Press to interrupt a continuous copying job when you need to make priority copies.
- ⑰ **Additional Functions key**  
Press to specify additional functions.
- ⑱ **Help key**  
Press to display explanations of modes or functions on the touch panel display.
- ⑲ **Reset key**  
Press to restore the standard settings of the machine.
- ⑳ **Touch Panel Display**  
The settings screen for each function is shown on this display.

# Touch Panel Display

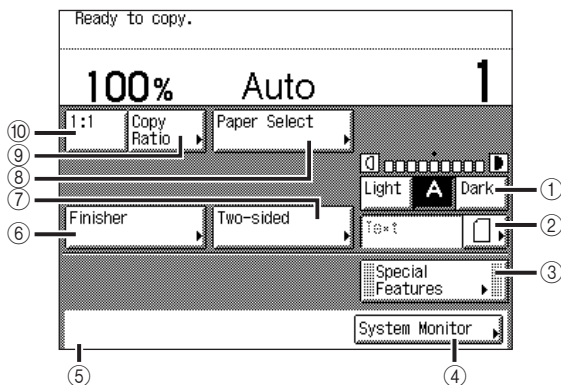

## ① Adjust Contrast

Press [Light] or [Dark] to manually control the copy exposure. Press [A] to select or cancel the automatic exposure control.

## ② Original Type Selection

Press to make copies according to the type of original ([Text], [Text/Photo], [Printed Img.], or [Photo]).

## ③ Special Features

Press to select a Special Features mode.

## ④ System Monitor

Press to check the progress of a copy job, change the order of printing, or cancel printing.

## ⑤ Job/Print Status Display Area

The progress of jobs and copy operations, and the status of devices and consumables are displayed here.

## ⑥ Finisher

Press to select the Collate, Group, or Staple mode.

## ⑦ Two-sided

Press to make [1▶2-Sided], [2▶2-Sided], [2▶1-Sided], or [Book▶2-Sided] copies.

## ⑧ Paper Select

Press to select the paper size/type and the paper source.

## ⑨ Copy Ratio

Press to reduce or enlarge the copy size.







## ⑩ 1:1





Press to make copies in the same size as your original.

- You can set the initial screen (the first screen that appears when the machine is turned ON) from the Additional Functions screen. The initial screen can be the Copy, Fax, Mail Box, or System Monitor screen.

 **NOTE**

The meanings of the icons that appears in the Job/Print Status Display Area (on the bottom left of the screen) are described below:

Icon (Type of Job)	Description
	Copy Job
	Fax Job
	Mail Box Job
	Printer Job
	Report Job
	Network Scan Job
	Additional Functions Job

Icon (Machine Status)	Description
	Error
	Paper Jam
	Staple Jam
	Replace Toner Cartridge

# Main Power and Control Panel Power

The machine is provided with two power switches, a main power switch and a control panel power switch, as well as a breaker that detects excess current or leakage current.

## How to Turn ON the Main Power

- 1 Make sure that the power plug is firmly inserted into the power outlet.

### WARNING

Do not connect or disconnect the power cord with wet hands, as this may result in electrical shock.

- 2 Press the main power switch to the "I" side. The main power switch is located on the right side of the machine.

For instructions on turning OFF the main power, see "How to Turn OFF the Main Power," in the *Reference Guide*.

The main power indicator on the control panel lights when the main power switch is turned ON.

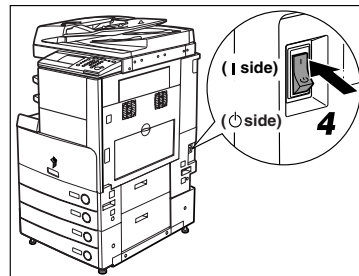

### IMPORTANT

If the main power indicator on the control panel does not light even though the main power switch is ON, be sure to check the breaker to see if it is OFF. (See "When the Power Does Not Turn ON," in the *Reference Guide*.)

### 3 The screens on the right are displayed while the system software is loading.

- ❑ The Start Up screen is displayed until the machine is ready to scan.

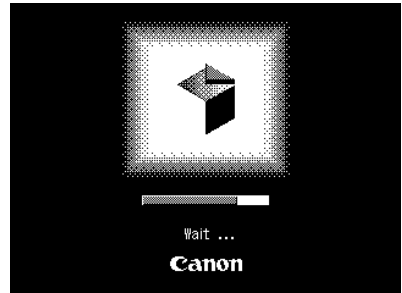

- ❑ The screen on the right is displayed when the machine is ready to scan.  
The machine is ready to scan in approximately 15 seconds (at a room temperature of 20°C) after the screen on the right appears (approximately 30 seconds if the optional iR System Expansion Kit is installed).

#### IMPORTANT

- If you turn OFF the main power, wait at least 10 seconds before turning the main power back ON.
- Do not turn the main power OFF if the optional Super G3 FAX Board is attached, and you want to be able to send or receive or fax documents. Sending or receiving fax documents cannot be done when the power is turned OFF.

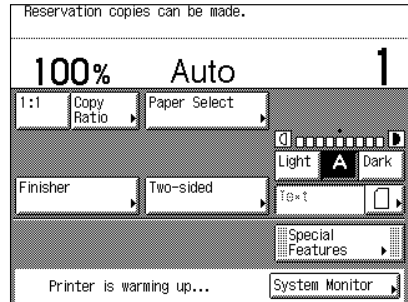

# Things You Must Do Before Using This Machine

This section describes the important setting registrations and procedures that must be done before the machine is used for sending operations. For the further details of the operations, see "Things You Must Do Before Using This Machine" in the *Facsimile Guide*.

## IMPORTANT

*If you attempt to use the machine without registering the necessary information correctly, the machine may not function properly.*

## Selecting the Type of Telephone Line

Set the type of telephone line that is connected to the machine.

### NOTE

- For this setting, the optional Super G3 FAX Board is required.
- The default setting is 'Tone'.

**1** Press  → [Custom Fax Settings].

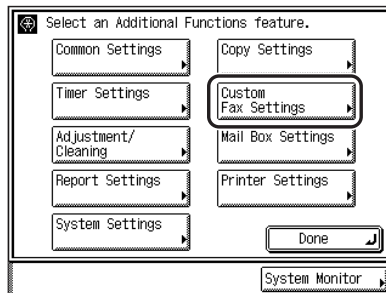

**2** Press [User Settings].

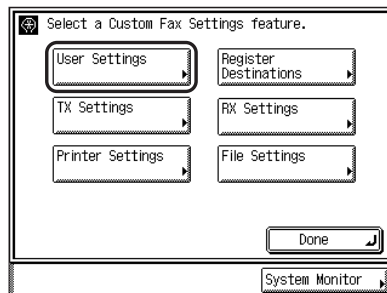

**3** Press [▼] or [▲] until [Tel Line Type] appears → press [Tel Line Type].

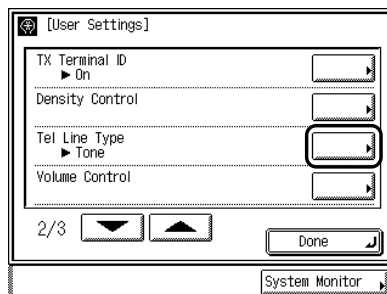

**4** Select the type of telephone line → press [OK].

The selected mode is set.

**5** Press [Done] repeatedly until the Basic Features screen appears.

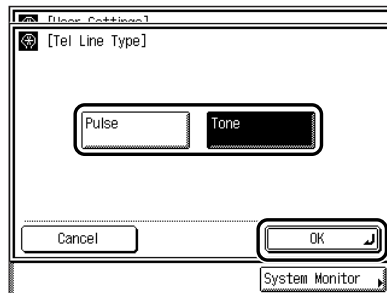

## Setting the Current Date and Time

You can set the current date and time. The current date and time settings are used as standard timer settings for functions that require them.

- **GMT:** The time at the Greenwich Observatory in England is called GMT (Greenwich Mean Time).
- **Time Zone:** The standard time zones of the world are expressed globally in terms of the difference in hours ( $\pm$  up to 12 hours) from GMT ( $\pm$  0 hours). A time zone is a region throughout which this time difference is the same.
- **Daylight Saving Time:** In some countries, time is advanced throughout the summer season. The period in which this is applied is called "Daylight Saving Time."

 **NOTE**

*You can also specify to automatically synchronize the date and time with a server on the network from the Additional Functions screen. (See Chapter 3, "Using a TCP/IP Network," in the Network Guide.)*

**1** Press  → [Timer Settings].

**2** Press [Date & Time Settings].

 **NOTE**

*If the desired setting is not displayed, press [▼] or [▲] to scroll to the desired setting.*

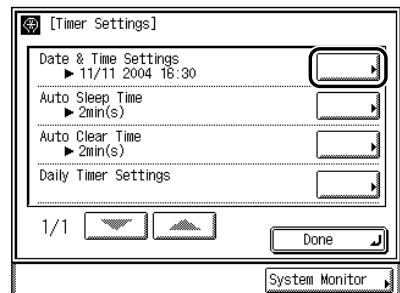

### 3 Enter the current date (day, month, year) and time using $\text{\textcircled{0}}$ - $\text{\textcircled{9}}$ (numeric keys).

#### ● If you are setting the Time Zone:

- Press [Time Zone Settings] → select the time zone where the machine is located → press [OK].

#### NOTE

- The default setting is 'GMT 0:00'.
- If the desired time zone is not displayed, press [▼] or [▲] to scroll through the list.

#### ● If you are setting Daylight Saving Time:

- Press [DaylightSaving Time Settings] → [On] → [Start Date].

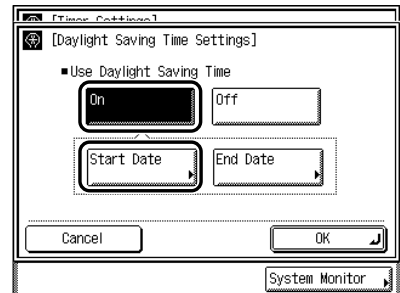
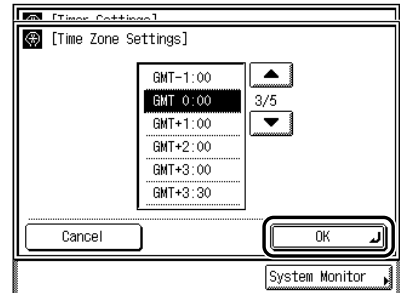
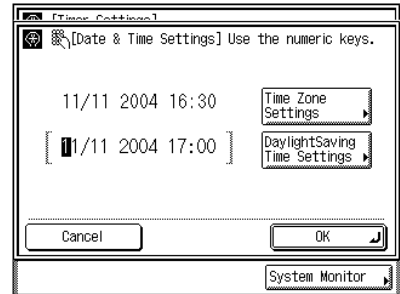

- ❑ Select the month and day from the Month and Day drop-down lists, respectively.
- ❑ Press [-] or [+] to enter the time of day you want Daylight Saving Time to take effect → press [OK].

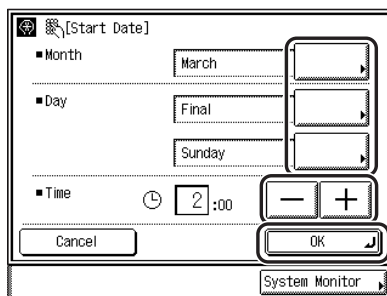

- ❑ Press [End Date] → make the settings in the same way as [Start Date] → press [OK].
- ❑ Press [OK].



**NOTE**

- If you set Daylight Saving Time, the machine automatically sets the standard time of the machine one hour forward at the specified date and time.
- The default setting is 'On'. Between 2:00 a.m. on the last Sunday of March and 3:00 a.m. on the last Sunday of October.
- The time can be set in one hour increments, from 0 to 23 hours.

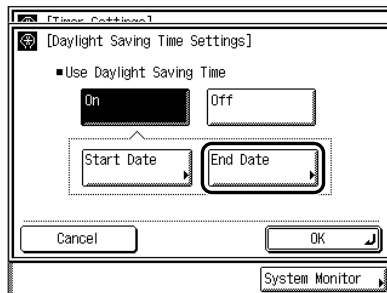

**4 Press [OK].**

The selected mode is set.

**5 Press [Done] repeatedly until the Basic Features screen appears.**



## Registering This Machine's Fax Number

You must store the machine's fax number. This number is printed on the document that you fax to the receiving party.

The number may also be displayed on the touch panel display of the receiving party's machine, depending on their type of machine.

 **NOTE**

*For this setting, the optional Super G3 FAX Board is required.*

- 1** Press  → [Custom Fax Settings] → [User Settings].
- 2** Press [Unit Telephone #].
- 3** Enter the unit's telephone number using  -  (numeric keys) → press [OK].  
The selected mode is set.
- 4** Press [Done] repeatedly until the Basic Features screen appears.

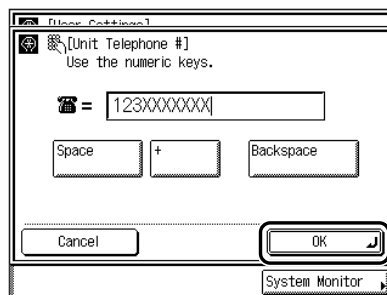

## Registering Sender Names

You can register any name as the sender's name, such as the section or department's name, or an individual's name.



### NOTE

*You can set to display and print the sender's name instead of the name stored as the unit's name with the Sender's Names setting from the Special Features screen. (See "Sender's Name as the Terminal ID," in the Facsimile Guide.)*

**1** Press  → [Custom Fax Settings] → [User Settings].

**2** Press [Sender's Names (TTI)].

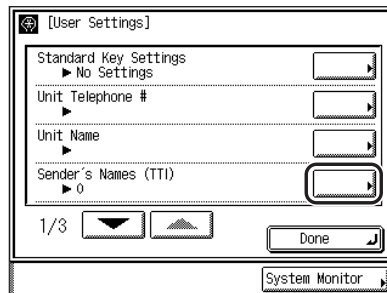

**3** Select the number under which you want to register the sender's name → press [Register].

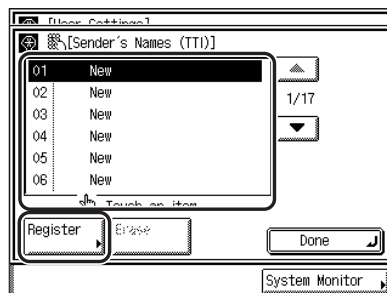

**4** Enter the sender's name → press [OK].

You can enter up to 24 characters for the sender's name.

To cancel registering the sender's name, press [Cancel].

The selected mode is set.

**5** Press [Done] repeatedly until the Basic Features screen appears.

## Registering the Unit's Name

Your name or company's name must be registered as the unit's name (a department name is optional).

When you send a document, the recipient's machine displays or prints your name or company's name (and department's name, if applicable) as the sender's information on the recording paper.

Some fax models also display sender information on the touch panel display during transmission.

---

**1** Press  → [Custom Fax Settings] → [User Settings].

**2** Press [Unit Name].

**3** Enter a name → press [OK].

The selected mode is set.

**4** Press [Done] repeatedly until the Basic Features screen appears.

# Displaying a Help Screen

Pressing **?** brings up a guidance screen with information about the various features that are available with your machine.

## ■ Usage Help

Pressing **?** after selecting a mode brings up a guide screen with an explanation of that mode. Use this help function if you do not understand how to use the mode you are setting.

In this example, the Margin mode has been selected. If you press **?** after pressing [Special Features] → [Margin], the Help Function screen appears as shown on the right.

To display the Help Menu screen, press [Help Menu].

To return to the screen for setting the Margin mode, press [Done].

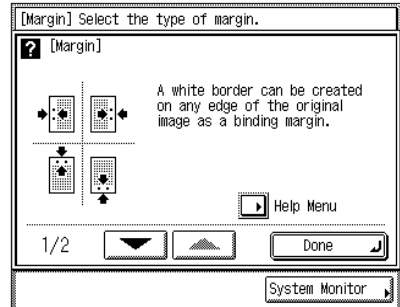

The Help Function Screen

## ■ Help Menu

To find the right mode for your particular needs or to find a simple description of a mode, press **?** while the Basic Features screen or Special Features screen is displayed. The Help Menu screen appears on the touch panel display, as shown on the right.

For example, if you are copying photo originals:

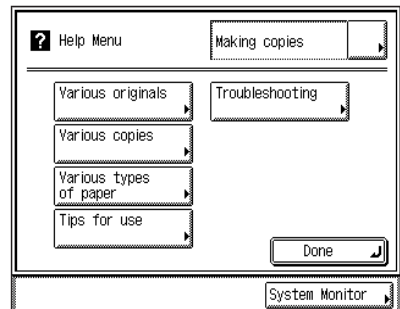

The Help Menu Screen

- 
- 1** Press [Making copies] → [Various originals].
  - 2** Press [Photo original] or [Originals with Text/Photo] → press [▼] or [▲] to read the detailed information on the selected mode.
  - 3** Press [Done] to return to the Various Originals screen.
  - 4** Press [Done] to return to the Help Menu screen.

# Routine Maintenance

# 2

## CHAPTER

This chapter describes how to load paper, and replace toner.

---

Loading Paper . . . . .	.2-2
Replacing the Toner Cartridge . . . . .	.2-5

# Loading Paper

If the selected paper has run out during printing, a screen prompting you to load paper appears on the touch panel display.



## IMPORTANT

- A screen prompting you to load paper also appears if the selected paper drawer is not fully inserted into the machine. Make sure that the paper drawer is properly in place.
- Do not load paper of an irregular size into the paper drawers.
- Do not load the following types of paper into the paper drawers. Doing so may cause a paper jam.
  - Severely curled or wrinkled paper
  - Thin straw paper
  - Transparencies
  - Paper which has been printed on using a thermal transfer printer (Do not print on the reverse side of this paper either.)
- Fan the stack of paper well before loading it.
- Never place paper or any other items in the empty part of the drawer next to the paper stack. Doing so may cause paper jams.



## NOTE

- If a message prompting you to load paper appears during printing, the remaining prints are automatically made after you load the correct paper. If you select another paper drawer, the remaining prints are made after you press [OK].
- To cancel printing, press [Cancel].
- The following paper sizes can be loaded into paper drawers 1, 2, 3, and 4:
  - Paper drawer 1: A4, A4R, A5R, and envelopes
  - Paper drawer 2, 3, 4: A3, A4, A4R, and A5R
  - Envelopes can be loaded into the paper drawer 1 only if the optional Envelope Feeder Attachment-C1 is attached.
  - Paper drawers 3 and 4 can be used only if the optional Cassette Feeding Unit-Y2 is attached.
- For more information on available paper stock that can be loaded into the paper drawers, see "Available Paper Stock," on p. 4-4.

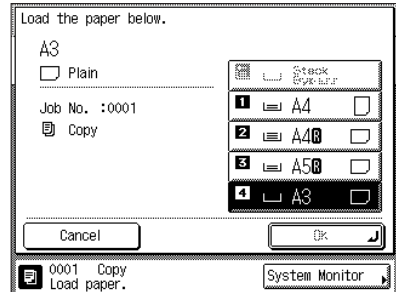

- 1 Press and release the button on the paper drawer in which you want to load paper.

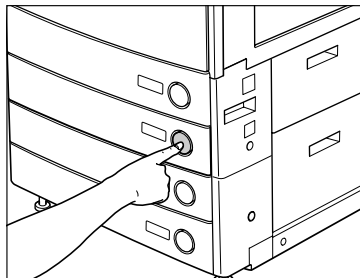

- 2 Grip the handle, and pull out the paper drawer until it stops.

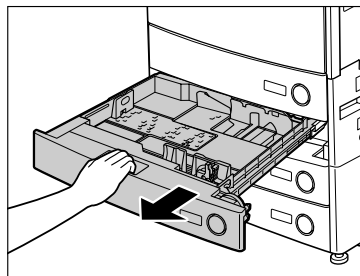

- 3 Open a package of paper, and remove the paper stack.

 **CAUTION**

When loading paper, take care not to cut your hands on the edges of the paper.

 **IMPORTANT**

Rewrap any remaining paper in its original package, and store it in a dry place, away from direct sunlight.

 **NOTE**

- For high-quality printouts, use paper recommended by Canon.
- Before loading paper, always fan the sheets several times, and align the edges to facilitate feeding. Also, you should always fan paper that has just been removed from a newly opened paper package.

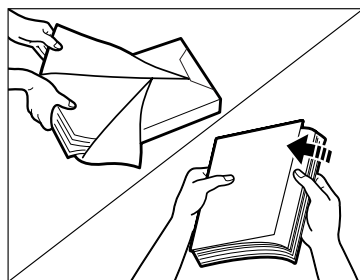

## 4 Load the paper stack into the paper drawer.

Even out the edges of the paper stack. Load the paper stack against the right wall of the paper drawer.

When loading paper into the paper drawer for the first time, set the paper size dial to match the paper size being loaded. (See "Adjusting a Paper Drawer to Hold a Different Paper Size," in the *Reference Guide*.)

When loading paper into the paper drawer, make sure that the paper size setting is the same size of the paper that is being loaded.

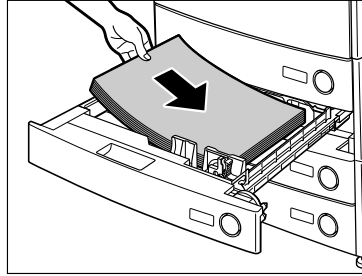

### IMPORTANT

- Paper which has been rolled or curled must be straightened out prior to use.
- Make sure that the height of the paper stack does not exceed the loading limit mark (  ) at the back of the paper drawer.

### NOTE

- Each paper drawer holds approximately 550 sheets of paper (80 g/m<sup>2</sup>).
- For more information on the print direction of preprinted paper (paper which has logos or patterns already printed on it), see "Relationship between Original Orientation and Preprinted Paper Output Chart," in the *Reference Guide*.

## 5 Gently push the paper drawer back into the machine until it clicks into place in the closed position.

### CAUTION

When returning the paper drawer to its original position, be careful not to get your fingers caught, as this may result in personal injury.

### IMPORTANT

You will not be able to make copies or print if you load paper that exceeds the loading limit, or if the paper drawer is not completely pushed into the machine. Always check that the paper drawers are in place. If a paper drawer is overloaded, decrease the amount of paper so that it does not exceed the loading limit.

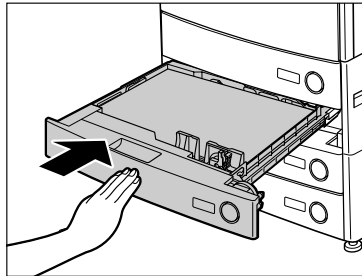

# Replacing the Toner Cartridge

When there is only a small amount of toner remaining inside the machine, the following message appears on the touch panel display, as shown. You can continue printing, but at this time you should purchase new toner cartridge so that you have it available when needed.

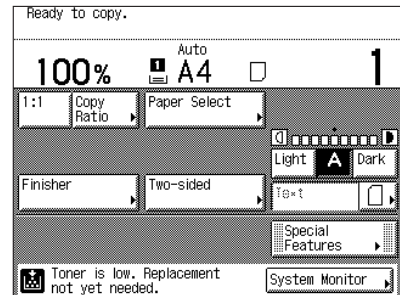

When toner runs out completely and prints can no longer be made, a screen with instructions on how to replace the toner cartridge, like the one shown on the right, appears on the touch panel display. Follow the instructions on the touch panel display, and the procedure described below to help you replace the toner cartridge.

With [Recover Later], you can continue certain operations, such as mode settings and scanning of originals, even if you do not replace the toner cartridge immediately.

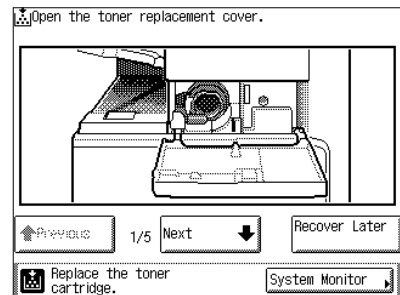

## CAUTION

- Keep toner out of the reach of small children. If toner is ingested, consult a physician immediately.
- If toner gets onto your hands or clothing, wash it off immediately with cold water. Do not use warm water as this may set the toner permanently, and you may not be able to remove the toner stains.

**IMPORTANT**

- Use only the toner cartridges intended for use with this machine.
- Do not replace toner cartridges until the message prompting you to do so appears.
- Do not replace toner cartridges while the machine is in the process of printing.

**NOTE**

- When the message <Toner is low. Replacement not yet needed.> appears, approximately 1,000 pages can be printed.
- If toner runs out during a print job, the remaining prints are made after you replace the toner cartridge.

**1** Open the toner supply port cover.

**2** Pull the lever up until it becomes vertical.

**IMPORTANT**

Make sure that the ▼ on the lever is aligned with the ▲ of the 'Unlock' position.

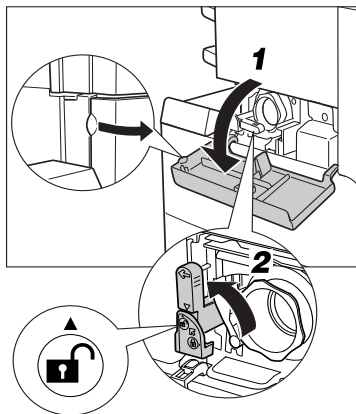

### 3 Pull the toner cartridge out of the toner supply port.

Pull the toner cartridge out halfway, then remove it completely while supporting it with your other hand from underneath.

#### WARNING

Do not burn or throw used toner cartridges into open flames, as this may cause the toner remaining inside the cartridges to ignite, resulting in burns or a fire.

#### CAUTION

Do not touch the tip of the toner cartridge or subject it to a shock by hitting something with it, as this may cause the toner cartridge to leak.

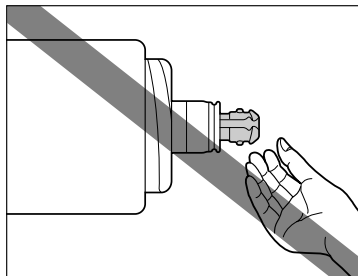
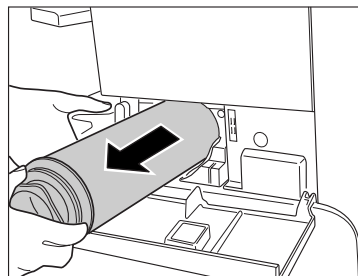

### 4 Twist the red protective cap of the new toner cartridge in the direction of the arrow (counterclockwise) to remove it.

#### CAUTION

Never touch the tip of the toner cartridge or subject it to a shock by hitting something with it. Doing so may cause the toner cartridge to leak.

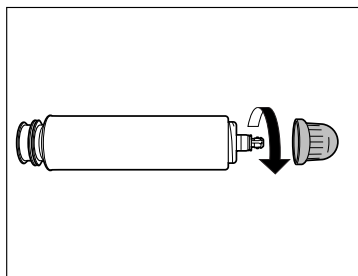

## 5 Push the new toner cartridge in as far as possible.

Support the new toner cartridge with your hand from underneath while pushing it into the machine with your other hand.

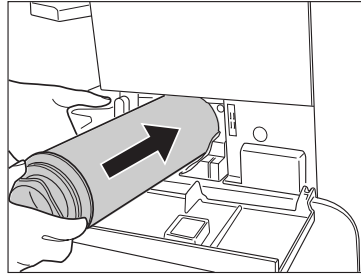

## 6 Push the lever down until it becomes horizontal.

### IMPORTANT

Make sure that the ▼ on the lever is aligned with the ► of the 'Lock' position.

### NOTE

If you insert a toner cartridge made for a different model, the lever does not move.

## 7 Close the toner supply port cover.

### CAUTION

When closing the cover, be careful not to get your fingers caught, as this may result in personal injury.

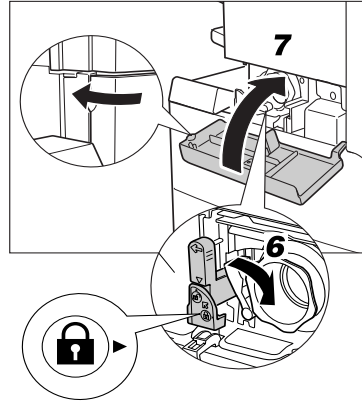

# Troubleshooting

# 3

## CHAPTER

This chapter explains what to do in response to a paper jam and an error message display.

---

Clearing Paper Jams . . . . .	3-2
List of Error Messages . . . . .	3-6
List of Error Codes without Messages . . . . .	3-6

# Clearing Paper Jams

The screen indicating the location of the paper jam and instructions on how to clear the paper jam appear on the touch panel display. This screen repeatedly appears on the touch panel display until the paper jam is entirely cleared. The location of the paper jam is indicated, by a red circle, on the top right corner of the screen.

## WARNING

There are some areas inside the machine which are subject to high-voltages. When removing jammed paper or when inspecting the inside of the machine, do not allow necklaces, bracelets, or other metal objects to touch the inside of the machine, as this may result in burns or electrical shock.

## CAUTION

- When removing jammed originals or paper, take care not to cut your hands on the edges of the originals or paper.
- When removing paper which has become jammed inside the machine, take care not to cut your hands or injure yourself on the inside of the machine. If you cannot remove the paper, please contact a service representative.
- When removing paper which has become jammed inside the machine, take care not to allow the toner on the jammed paper to come into contact with your hands or clothing, as this will dirty your hands or clothing. If they become dirty, wash them immediately with cold water. Washing them with warm water will set the toner, and make it impossible to remove the toner stains.
- When removing paper which has become jammed inside the machine, remove the jammed paper gently to prevent the toner on the paper from scattering and getting into your eyes or mouth. If the toner gets into your eyes or mouth, wash them immediately with cold water and immediately consult a physician.
- The fixing unit and its surroundings inside the machine may become hot during use. When removing jammed paper or when inspecting the inside of the machine, do not touch the fixing unit and its surroundings, as doing so may result in burns or electrical shock.
- Remove your hands from the machine immediately after removing paper jams, as the rollers may catch your hands or clothing, and result in personal injury.

## NOTE

- If you press [Recover Later], you can continue operating the machine, such as you can set mode settings and scan originals, even if the jammed paper is not removed immediately.
- If paper is jammed in several locations, remove the jammed paper in the order indicated on the touch panel display.

## 1 Inspect all paper jam locations indicated on the touch panel display, and remove any jammed paper.

See the appropriate pages below for instructions on finding and removing jammed paper. Or, you can follow the instructions on the touch panel display.

If jammed paper tears while it is being removed, be sure to remove any remaining pieces from inside the machine.

### IMPORTANT

- If the machine's power is turned OFF when there is a paper jam, detection of paper jams in the paper drawers is not possible after the power is turned back ON. Clear paper jams without turning the power OFF.
- If a paper jam occurs in the optional Feeder (DADF-N1), you cannot continue operating the machine. Follow the directions on the touch panel display to clear the paper jam. (See "Feeder (DADF-N1) (Optional)," in the Reference Guide.)

### ● If a paper jam occurs inside the main unit:

- See the instructions on the following section.

- ① Fixing Unit (See "Fixing Unit (Inside the Main Unit)," in the Reference Guide.)
- ② Duplexing Unit (See "Duplexing Unit (Inside the Main Unit)," in the Reference Guide.)
- ③ Stack Bypass (See "Stack Bypass," in the Reference Guide.)
- ④ Paper Drawer 1 (See "Paper Drawer 1," in the Reference Guide.)
- ⑤ Paper Drawer 2 (See "Paper Drawer 2," in the Reference Guide.)

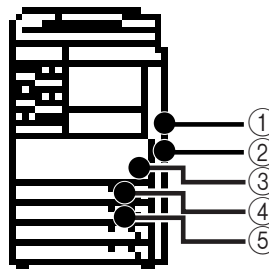

### NOTE

Some areas that are shown to have paper jams may not actually have paper jams. However, always check all locations indicated on the touch panel display in the order that is given.

**● If a paper jam occurs inside an optional unit:**

□ See the instructions on the following section.

- ① Feeder (DADF-N1) (See "Feeder (DADF-N1) (Optional)," in the *Reference Guide*.)
- ② Inner 2 Way Tray-D1 (See "Inner 2 Way Tray-D1 (Optional)," in the *Reference Guide*.)
- ③ Cassette Feeding Unit-Y2 (See "Cassette Feeding Unit-Y2 (Optional)," in the *Reference Guide*.)
- ④ Copy Tray-J1 (See "Copy Tray-J1 (Optional)," in the *Reference Guide*.)
- ⑤ Finisher-S1 (See "Finisher-S1 (Optional)," "Finisher-S1/Puncher Unit-Q1 (Optional)," or "Inside the Transfer Cover of the Finisher-S1 (Optional)," in the *Reference Guide*.)

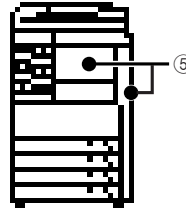
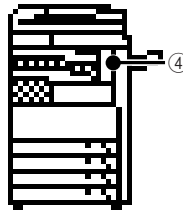
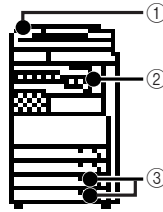

**2** After you have removed all of the jammed paper at the locations indicated on the touch panel display, restore all levers and covers to their original positions.

**3** Continue to follow the procedure and instructions displayed on the touch panel display.

Once you have removed all of the jammed paper in locations other than the feeder, printing or copying resumes.

If there is paper that still needs to be removed, a screen indicating how to clear that paper jam appears on the touch panel display. Repeat the procedure from step 1.



**NOTE**

*You do not have to re-enter the number of copies or prints, even if you are printing multiple sets. The machine automatically recalculates the number of copies or prints to make based on the number of sheets that have jammed.*

# List of Error Messages

## List of Error Codes without Messages

If a job or operation does not complete successfully, check the error code, and perform the necessary operations according to the error code displayed. You can check the error code on the Details screen under [Log] from the System Monitor screen. (See "Checking Copy/Print Job Details," in the *Reference Guide*.)

If a send, receive, or fax job does not complete successfully, the error code is printed in the Results column on the Activity Report and Send Report. (See "Printing Communication Reports," in the *Facsimile Guide*.)

Perform the necessary procedures according to the error code.



### NOTE

If a send job is cancelled, <STOP> is printed in the Results column on the Send report.

---

#### # 001

---

**Cause** Paper or originals are jammed.

**Remedy** Remove any jammed paper or originals. (See "Clearing Paper Jams," or "Feeder (DADF-N1) (Optional)," in the *Reference Guide*.)

---

#### # 009

---

**Cause 1** There is no paper.

**Remedy** Load paper. (See "Paper Drawers," in the *Reference Guide*.)

**Cause 2** The paper drawer is not inserted correctly into the machine.

**Remedy** Insert the paper drawer properly. (See "Paper Drawers," in the *Reference Guide*.)

---

#### # 037

---

**Cause** Documents could not be received because there was insufficient memory available.

**Remedy** Erase unwanted documents and documents with errors from memory in order to increase the amount of available memory. (See "Introduction to the Mail Box Functions," in the *Copying and Mail Box Guide*, or "Special Fax Functions," in the *Facsimile Guide*.)

---

---

**# 099**

---

**Cause** Copying/printing was interrupted.

**Remedy** Try copying/printing again.

---

**# 701**

---

**Cause** The specified Department ID does not exist, or the password has changed.

**Remedy** Enter the correct Department ID or password using ① - ⑨ (numeric keys) on the control panel, and try again.

---

**# 703**

---

**Cause** The hard disk is full, and no more images can be scanned.

**Remedy 1** Wait a few moments, and try scanning again after other send jobs are complete.

**Remedy 2** Erase documents stored in inboxes. If the machine still does not operate normally, turn the main power OFF, and then back ON again.

---

**# 711**

---

**Cause** The inbox memory is full.

**Remedy** Erase the unnecessary documents stored in the inbox.

---

**# 712**

---

**Cause** The maximum number of documents are already stored in the inbox.

**Remedy** Erase the unnecessary documents stored in the inbox.

---

**# 749**

---

**Cause** You could not execute the job because a service call message is being displayed.

**Remedy** Turn the main power OFF, wait for three or more seconds, and turn the main power back ON. If the machine still does not work normally, turn the main power OFF, disconnect the machine, and contact your local authorized Canon dealer.

---

**# 816**

---

**Cause** You cannot print because the set page Limit total has been reached.

**Remedy** Contact your System Manager.

---

---

**# 851**

---

**Cause 1** There is insufficient memory remaining in the system.

**Remedy** Check the system's available memory, and delete any unnecessary documents stored in the inboxes.

**Cause 2** The scanned document cannot be stored because there are more than 100 documents in the specified inbox.

**Remedy** If there are a large number of documents, delete them from the specified inbox.

---

**# 852**

---

**Cause** An error occurred because the main power switch was turned OFF while a job was being processed.

**Remedy** Check to see if the main power switch is turned ON. Try processing the job again, if necessary.

---

**# 853**

---

**Cause** When trying to print a large number of pages, the job is not performed due to insufficient memory resources.

**Remedy** Reduce the number of pages to print, or perform the print job again when no other jobs are reserved.

# Appendix

# 4

## CHAPTER

This chapter provides other useful information.

---

Multifunctional Operations . . . . .	4-2
Available Paper Stock . . . . .	4-4
Check Sheet for the Periodic Inspection of the Breaker . . . . .	4-6

# Multifunctional Operations

The iR3530/iR2230 offers the user many functions, such as printing, scanning, copying, and sending, which can be used together. The following table provides you with the details of multifunctional operations.

–: Unavailable due to the duplicate devices

×: Operationally unavailable

△: Available. Automatically resume the next job after performing the previous job.

✓: Available

		Copy		Mail box	
		Scanning data	Printing	Scanning data	Printing
Copy		–	△	–	△
Mail Box	Scanning data	–	✓	–	✓
	Printing	✓	△	×	△
Fax	TX (scanning included)	–	✓	–	✓
	Memory TX	✓	✓	✓	✓
	Memory RX	✓	✓	✓	✓
	Printing of Auto RX Documents	✓	△	✓	△
Printer	Receiving data	✓	✓	✓	✓
	Printing	✓	△	✓	△

		Fax				Printer	
		Scanning data	TX	RX	Printing of Auto RX Documents	Receiving data	Printing
Copy		–	✓	✓	△	✓	△
Mail box	Scanning data	–	✓	✓	✓	✓	✓
	Printing	✓	✓	✓	△	✓	△
Fax	TX (scanning included)	–	✓	✓	✓	✓	✓
	Memory TX	✓	△	△	✓	✓	✓
	Memory RX	✓	–	–	✓	✓	✓
	Printing of Auto RX Documents	✓	✓	✓	△	✓	△
Printer	Receiving data	✓	✓	✓	✓	–	✓
	Printing	✓	✓	✓	△	✓	△













**NOTE**

'TX (scanning included)' includes a reservation of the direct sending.

# Available Paper Stock

The paper types that can be used with this machine are shown in the following table. Icons indicating the type of paper loaded in each paper drawer can be displayed on the paper selection screen if you store that information in the machine beforehand. (See "Identifying the Type of Paper in a Paper Source," in the *Reference Guide*.)

✓: Available    –: Unavailable

Paper Type	Paper Source	
	Paper Drawer (64 to 80 g/m <sup>2</sup> )	Stack Bypass (64 to 128 g/m <sup>2</sup> )
Plain* <sup>1</sup> 	✓	✓
Recycled* <sup>1</sup> 	✓	✓
Colour* <sup>1</sup> 	✓	✓
Pre-punched* <sup>1</sup> 	–	✓
Bond 	–	✓
Heavy* <sup>2</sup> 	–	✓
Tracing Paper 	–	✓* <sup>3</sup>
Transparency* <sup>4</sup> 	–	✓
Labels 	–	✓
Envelopes 	✓* <sup>5</sup>	✓

\*1 Plain, Recycled, Colour, and Pre-punched paper are from 64 to 80 g/m<sup>2</sup>.

\*2 Heavy paper is from 81 to 128 g/m<sup>2</sup>.

\*3 Some types of tracing paper cannot be used.

\*4 Use only A4 transparencies made especially for this machine.

\*5 If the optional Envelope Feeder Attachment-C1 is attached to paper drawer 1, envelopes can be loaded.

Paper Size	Width x Length	Paper Source			
		Paper Drawer 1	Paper Drawer 2, 3, 4	Stack Bypass	
<b>A3</b>	297 mm x 420 mm	—	✓	✓	
<b>A4</b>	297 mm x 210 mm	✓	✓	✓	
<b>A4R</b>	210 mm x 297 mm	✓	✓	✓	
<b>A5R</b>	148 mm x 210 mm	✓	✓	✓	
<b>Envelope</b>	<b>ISO-B5</b>	176 mm x 250 mm	✓ <sup>*1</sup>	—	✓
	<b>ISO-C5</b>	162 mm x 229 mm	✓ <sup>*1</sup>	—	✓
	<b>COM 10</b>	104.7 mm x 241.3 mm	✓ <sup>*1</sup>	—	✓
	<b>Monarch</b>	98.4 mm x 190.5 mm	✓ <sup>*1</sup>	—	✓
	<b>DL</b>	110 mm x 220 mm	✓ <sup>*1</sup>	—	✓
	<b>Yougata 4</b>	105 mm x 235 mm	✓ <sup>*1</sup>	—	✓
<b>Free Size</b>	140 mm x 182 mm to 297 mm x 432 mm	—	—	✓	

\*1 If the optional Envelope Feeder Attachment-C1 is attached to paper drawer 1, envelopes can be loaded.



#### NOTE

- For instructions on loading paper, see the following sections:
  - Paper Drawers: "Loading Paper," in the Reference Guide
  - Stack Bypass: "Making Prints Using the Stack Bypass," in the Reference Guide
- Paper Drawers 3, 4 are optional.

