



How to Use This Manual  Printing This Manual

iP1900 series

# On-screen Manual

MC-2548-V1.00



## Basic Guide

Describes the summary of this product.



## Advanced Guide

Describes the detailed function of this product.



## Troubleshooting



## Contents

### ❖ Overview of the Printer

Main Components

---

### ❖ Printing

Printing Photos (Easy-PhotoPrint EX)

Printing Documents (Windows)

Printing Documents (Macintosh)

---

### ❖ Using More Utilities

Solution Menu and My Printer

---

### ❖ Loading Paper

Loading Paper

### ❖ Routine Maintenance

When Printing Becomes Faint or Colors Are Incorrect

Replacing a FINE Cartridge

Cleaning the Paper Feed Roller

Opening the Maintenance Screens

---

### ❖ Appendix

Safety Precautions

Legal Limitations on Use of Your Product and Use of Images

Tips on How to Use Your Printer

# Overview of the Printer

This section shows the component names of the printer and describes their functions.

## Main Components

[Front View](#)  
[Rear View](#)  
[Inside View](#)



[↑ Page top](#)

## Main Components

### ■ Front View

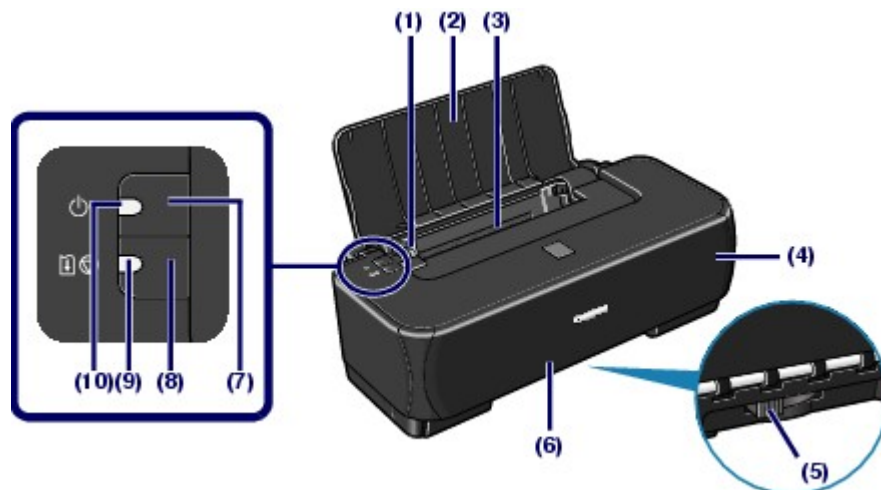

#### (1) Paper Guide

Pinch and slide it to align with the left side of the paper stack.

#### (2) Paper Support

Open to load paper in the Rear Tray.

#### (3) Rear Tray

Load various sizes or types of paper which you can use on the printer.

Two or more sheets of the same size and type of paper can be loaded at the same time, and fed automatically one sheet at a time.

See [Loading Paper](#).

#### (4) Front Cover

Open it when replacing the FINE Cartridges or removing jammed paper inside the printer.

#### (5) Paper Thickness Lever

Switches the clearance between the Print Head and the loaded paper to match the media type.



#### Note

##### Position of the Paper Thickness Lever

- Set to the right when printing on envelopes or T-shirt transfers.
- Set to the left when printing on paper other than envelopes or T-shirt transfers.

For details on the media types and the position of the Paper Thickness Lever, see [Media Types You can Use](#).

#### (6) Paper Output Slot

Printouts are output.

#### (7) Power Button

Turns the power on or off.



#### Important

##### Disconnecting the Power Plug

- When disconnecting the power plug after turning off the power, be sure to confirm that the **Power** lamp is not lit. If the power plug is disconnected from the wall outlet while the **Power** lamp is lit or flashing, the printer may become unable to print since the Print Head is not protected.

#### (8) RESUME/CANCEL Button

Press to cancel a print job in progress. You can also press this button after resolving a printer error to

dismiss an error message and resume printing.

### (9) Alarm Lamp

Lights or flashes orange when an error, such as paper-out or ink-out, occurs.

### (10) Power Lamp

Lights green after flashing when the power is turned on.



#### Note

#### Power and Alarm lamps

- You can check the status of the printer by the **Power** and **Alarm** lamps.
  - **Power** lamp Off: The power is off.
  - **Power** lamp lit green: The printer is ready to print.
  - **Power** lamp flashing green: The printer is getting ready to print, or printing is in progress.
  - **Alarm** lamp flashing orange: An error has occurred and the printer is not ready to print. For details, refer to the "[Troubleshooting](#)" in the on-screen manual: *Advanced Guide*.
  - **Power** lamp flashes green once and **Alarm** lamp flashes orange once alternately: An error that requires contacting your Canon service representative may have occurred. For details, refer to the "[Troubleshooting](#)" in the on-screen manual: *Advanced Guide*.

## ■ Rear View

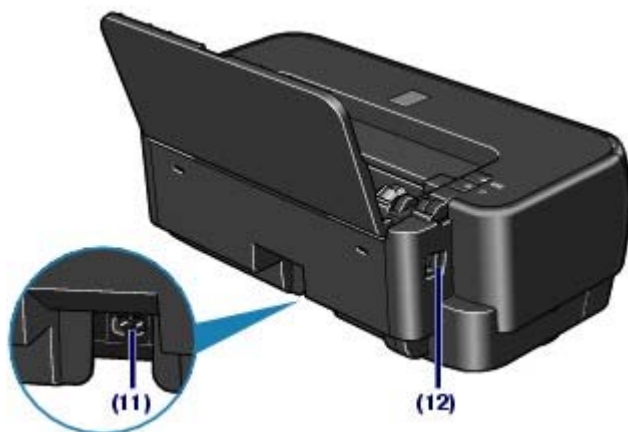

### (11) Power Cord Connector

Plug in the supplied power cord.

### (12) USB Port

Plug in the USB cable to connect with a computer.



#### Caution

- Do not touch the metal casing.

## ■ Inside View

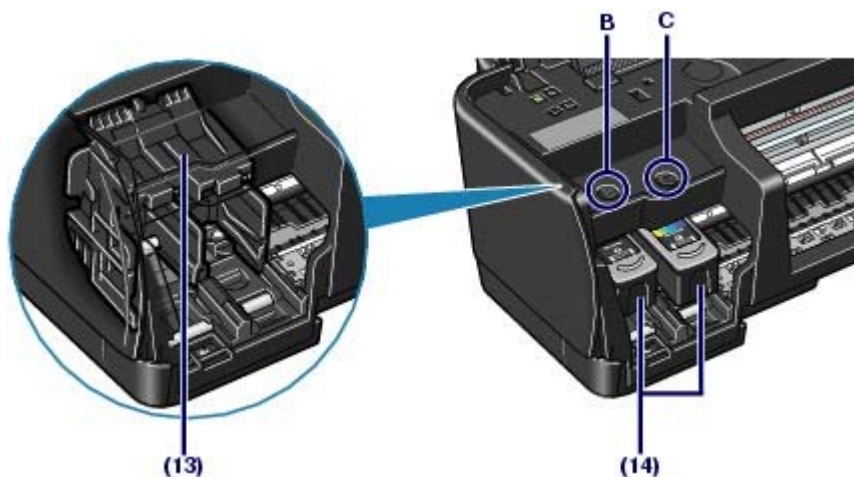

### (13) FINE Cartridge Holder

Install the FINE Cartridges.

The Black FINE Cartridge should be installed into the left slot (B) and the Color FINE Cartridge should be installed into the right slot (C).

#### (14) FINE Cartridges (Ink Cartridges)

A replaceable cartridge that is integrated with Print Head and ink tank.



##### Note

- For details on installing the FINE Cartridges, refer to the printed manual: *Getting Started*.



##### Important

- The area (A) indicated in the figure below may be splattered with ink. It does not affect the performance of the printer.  
Do not touch the area (A). The printer may not print out properly if you touch it.

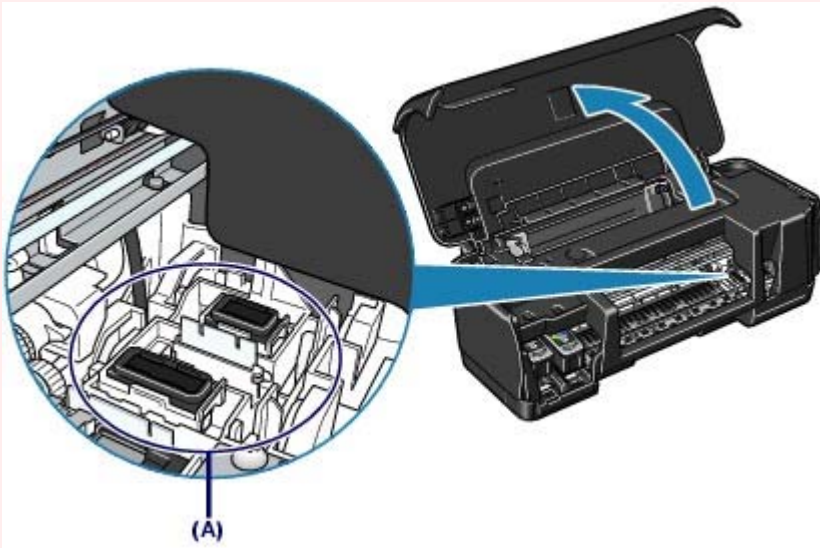

# Printing

This section describes how to print documents or photos.

You can easily print photos taken with your digital camera by using Easy-PhotoPrint EX supplied with your printer.

## Printing Photos (Easy-PhotoPrint EX)

[Using Various Functions of Easy-PhotoPrint EX](#)

## Printing Documents (Windows)

## Printing Documents (Macintosh)

[For Mac OS X v.10.5.x](#)

[For Mac OS X v.10.4.x or Mac OS X v.10.3.9](#)



[↑ Page top](#)

## Printing Photos (Easy-PhotoPrint EX)

Print image data saved on your computer by using Easy-PhotoPrint EX supplied with your printer.

This section describes the procedure, using print setting for borderless photo print on 4" x 6" / 10 x 15 cm photo paper as a sample.

For details on Easy-PhotoPrint EX, refer to the on-screen manual: [Advanced Guide](#).



### Note

- The screens used in this section are for printing with Windows. The operations are also the same for printing with Macintosh.
- Install Easy-PhotoPrint EX from the *Setup CD-ROM* when it has not been installed or has been uninstalled. To install Easy-PhotoPrint EX, select Easy-PhotoPrint EX in Custom Install.

## 1. Prepare for printing.

### (1) Make sure that the printer is turned on.

See [Front View](#).

### (2) Load paper.

See [Loading Paper](#).

Here we load 4" x 6" / 10 x 15 cm photo paper.



## 2. Start Easy-PhotoPrint EX, and select Photo Print.



### (1) Start Easy-PhotoPrint EX.



Double-click  (Easy-PhotoPrint EX) on the desktop.





Click Here: [Easy-PhotoPrint EX](#)





Select the Go menu, Applications, Canon Utilities, Easy-PhotoPrint EX, then double-click Easy-PhotoPrint EX.



**Note****Windows**

- To start Easy-PhotoPrint EX from Solution Menu, double-click  (Solution Menu) on the desktop and click  (Print photos or albums, etc.).  
See [To Start Solution Menu](#).
- To start Easy-PhotoPrint EX from the Start menu, select All Programs (Programs in Windows 2000), Canon Utilities, Easy-PhotoPrint EX, then Easy-PhotoPrint EX.

**Macintosh**

- To start Easy-PhotoPrint EX from Solution Menu, click  (Solution Menu) in the Dock and click  (Print photos or albums, etc.).  
See [To Start Solution Menu](#).



**(2) Click Photo Print.****Note**

- You can select Album, Calender, Stickers, etc., besides Photo Print.  
See [Using Various Functions of Easy-PhotoPrint EX](#).

**3. Select a photo to print.****(1) Select the folder in which images are saved.****(2) Click the image to print.**

The number of copies appears as "1", and the image you selected appears in the selected image area (A).  
You can select two or more images at the same time.

**Note**

- To print two or more copies, click  (Up arrow) to change the number of copies.
- To cancel the selection, click the image to cancel in the selected image area and click  (Delete Imported Image). You can also use  (Down arrow) to change the number of copies to zero.
- You can also correct or enhance the selected image.  
See [Using Various Functions of Easy-PhotoPrint EX](#).

**(3) Select Select Paper.****4. Select the loaded paper.**

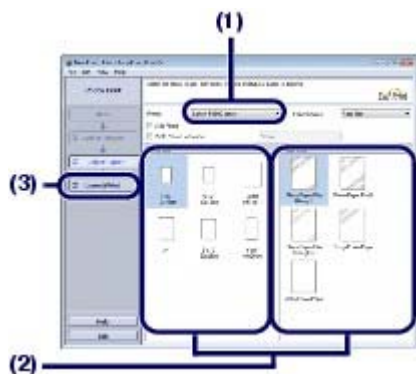

(1) Make sure that your printer's name is selected in Printer.

(2) Select the loaded paper in Paper Size and Media Type.

Here we select 4"x6" 10x15cm in Paper Size and the type of loaded photo paper in Media Type.



#### Note

- If you select the wrong media type, the printer may not print with the proper print quality.

(3) Click Layout/Print.

5. Select a layout and start printing.



(1) Select the layout of the photo.

Here we select Borderless [full].

The preview appears in the selected layout for confirmation of the required print result.



#### Note

- You can change the direction of a photo or crop a part of photo (trimming) to print.  
For details on the operation, refer to the on-screen manual: [Advanced Guide](#).

(2) Click Print.



#### Note

##### Windows

- To cancel a print job in progress, press the **RESUME/CANCEL** button on the printer or click Cancel Printing on the printer status monitor. To display the printer status monitor, click Canon XXX (where "XXX" is your printer's name) on the taskbar.

##### Macintosh

- Click the printer icon in the Dock to display the list of print jobs in progress.
- To cancel a print job in progress, select the desired job in the Name list and click Delete.



## ■ Using Various Functions of Easy-PhotoPrint EX

This section describes a few of the useful functions of Easy-PhotoPrint EX.

For details, refer to the on-screen manual: [Advanced Guide](#).

### ● Creating Your Own Prints

You can create an album or calendar using your photos.



Album



Calendar



Stickers



Layout Print

### ● Correcting Images

You can use Red-Eye Correction, Face Sharpener, Digital Face Smoothing, Brightness, Contrast, etc. to adjust, correct, or enhance images automatically or manually.

#### Sample of the correction

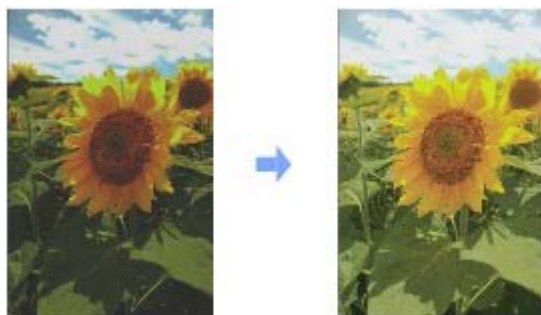

Brightness



## Printing Documents (Windows)



### Note

- Operations may vary depending on your software application. For details of the operation, refer to the instruction manual of your application.
- The screens used in this section are for printing with Windows Vista operating system Ultimate Edition (hereafter referred to as "Windows Vista").

### 1. Make sure that the printer is turned on.

See [Front View](#).

### 2. Load paper.

See [Loading Paper](#).

### 3. Create (or open) a document to print using an appropriate software application.

### 4. Open the printer properties dialog box.

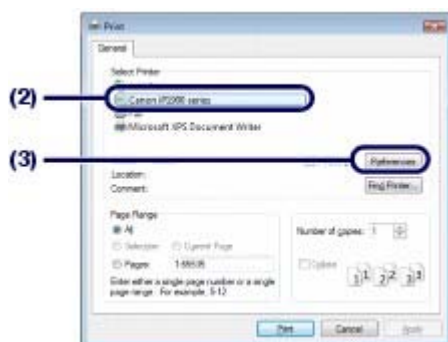

### (1) Select Print in the File menu or from the command bar in your software application.

The Print dialog box appears.

### (2) Make sure that your printer's name is selected.



### Note

- If another printer's name is selected, click and select your printer's name.

### (3) Click Preferences (or Properties).

### 5. Specify the required print settings.

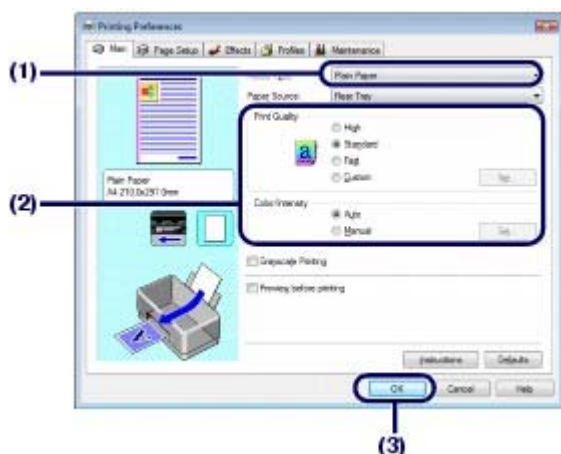

- (1) Select the media type of the loaded paper in Media Type.



#### Note

- If you select the wrong media type, the printer may not print with the proper print quality.

- (2) Specify the print quality, etc. in Print Quality and Color/Intensity as required.



#### Note

- For details on the print quality, refer to the on-screen manual: [Advanced Guide](#).

- (3) Click OK.



#### Note

- To confirm the page size, click the Page Setup tab. If the setting does not match the document's page size already set in the software application, you need to reset the page size, or otherwise use Scaled Printing or Fit-to-Page Printing. For details, refer to the on-screen manual: [Advanced Guide](#).
- For details on other printer driver functions, click Help or Instructions to view the online help or the on-screen manual: [Advanced Guide](#). The Instructions button appears on the Main and Maintenance sheets if the on-screen manual is installed on your computer.
- To display the preview to confirm the print result, select the Preview before printing check box in the Main sheet. Some software applications may not have a preview function.

## 6. Start printing.

Click Print (or OK) to start printing.



#### Note

- The message asking to confirm the position of the Paper Thickness Lever may appear. If the message appears, make sure that the Paper Thickness Lever is set properly. See [Loading Paper](#).
- To cancel a print job in progress, press the **RESUME/CANCEL** button on the printer or click Cancel Printing on the printer status monitor. To display the printer status monitor, click Canon XXX (where "XXX" is your printer's name) on the taskbar.
- If printed ruled lines are misaligned or print results are unsatisfactory, adjust the print head position. See [Aligning the Print Head](#).



[↑ Page top](#)

## Printing Documents (Macintosh)



### Note

- Operations may vary depending on your software application. For details of the operation, refer to the instruction manual of your application.

### ■ For Mac OS X v.10.5.x

#### 1. Make sure that the printer is turned on.

See [Front View](#).

#### 2. Load paper.

See [Loading Paper](#).

#### 3. Create (or open) a document to print using an appropriate software application.

#### 4. Open the Print dialog box.

Select Print on the File menu in your software application.

The Print dialog box appears.



### Note

- If the dialog box below appears, click  (Down arrow).



#### 5. Specify the required print settings.

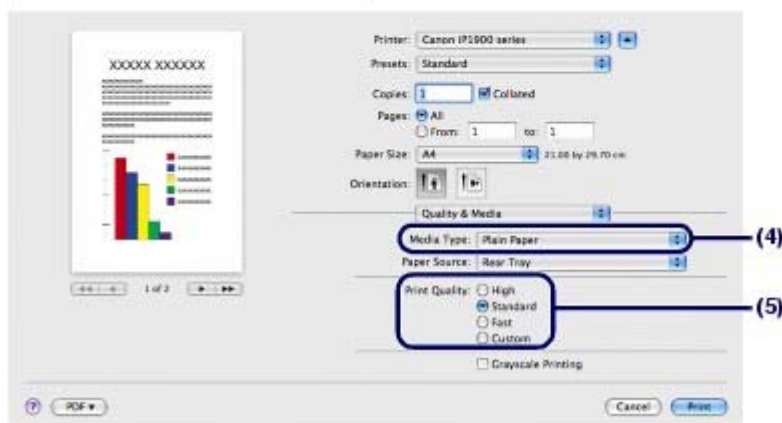
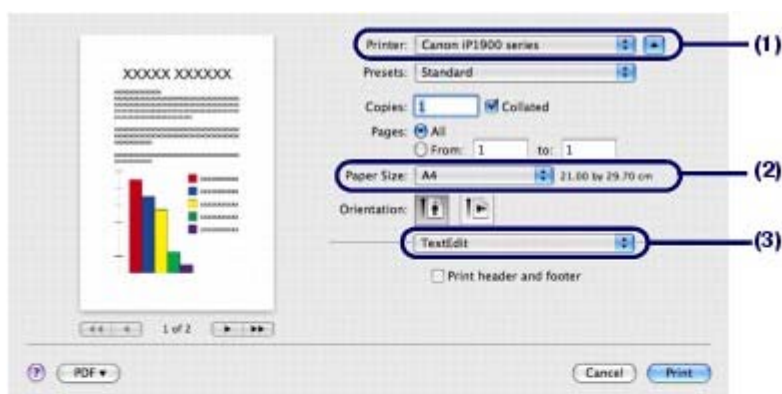

- (1) Make sure that your printer's name is selected in Printer.
- (2) Select the page size of the loaded paper in Paper Size.
- (3) Select Quality & Media in the pop-up menu.
- (4) Select the media type of the loaded paper in Media Type.

#### Note



- If you select the wrong media type, the printer may not print with the proper print quality.

- (5) Select the print quality in Print Quality.

#### Note

- For details on the print quality, refer to the on-screen manual: [Advanced Guide](#).

#### Note

- For details on other printer driver functions, click  (Question) on the Quality & Media, Color Options, Borderless Printing, or Margin screen to view the on-screen manual: *Advanced Guide*. If the on-screen manual is not installed, it does not appear even if  (Question) is clicked.
- The preview appears on the left of the dialog box to confirm the print result. Some software applications may not have a preview function.

## 6. Start printing.

Click Print to start printing.

#### Note

- Click the printer icon in the Dock to display the list of print jobs in progress.
- To cancel a print job in progress, select the desired job in the Name list and click Delete. To temporarily stop a job in progress, click Hold. To temporarily stop all the jobs in the list, click Pause Printer.
- If printed ruled lines are misaligned or print results are unsatisfactory, adjust the print head position. See [Aligning the Print Head](#).



## ■ For Mac OS X v.10.4.x or Mac OS X v.10.3.9

### Note

- The screens used in this section are for printing in Mac OS X v.10.4.x.

### 1. Make sure that the printer is turned on.

See [Front View](#).

### 2. Load paper.

See [Loading Paper](#).

### 3. Create (or open) a document to print using an appropriate software application.

### 4. Specify the page size.



- (1) Select Page Setup on the File menu in your software application.  
The Page Setup dialog box appears.

(2) Make sure that your printer's name is selected in Format for.

(3) Select the page size of the loaded paper in Paper Size.

(4) Click OK.

### 5. Specify the required print settings.

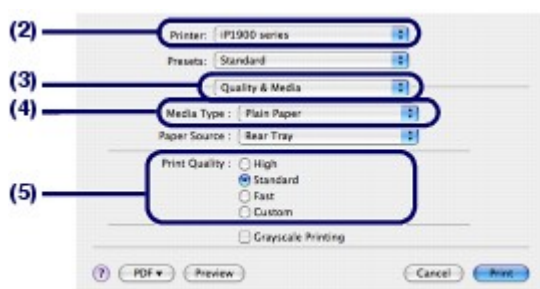

- (1) Select Print on the File menu in your software application.  
The Print dialog box opens.

(2) Make sure that your printer's name is selected in Printer.

(3) Select Quality & Media in the pop-up menu.

(4) Select the media type of the loaded paper in Media Type.

### Note

- If you select the wrong media type, the printer may not print with the proper print quality.
- 

## (5) Select the print quality in Print Quality.





### Note

- For details on the print quality, refer to the on-screen manual: [Advanced Guide](#).
- 



### Note

- For details on other printer driver functions, click  (Question) on the Quality & Media, Color Options, Special Effects, Borderless Printing, or Margin screen to view the on-screen manual: *Advanced Guide*. If the on-screen manual is not installed, it does not appear even if  (Question) is clicked.
  - To display the preview to confirm the print result, click Preview. Some software applications may not have a preview function.
- 

## 6. Start printing.

Click Print to start printing.



### Note

- Click the printer icon in the Dock to display the list of print jobs in progress.
  - To cancel a print job in progress, select the desired job in the Name list and click Delete. To temporarily stop a job in progress, click Hold. To temporarily stop all the jobs in the list, click Stop Jobs.
  - If printed ruled lines are misaligned or print results are unsatisfactory, adjust the print head position. See [Aligning the Print Head](#).
- 



# Using More Utilities

This section describes the useful functions to start supplied software applications on the desktop.

## **Solution Menu and My Printer**



 [Page top](#)

## Solution Menu and My Printer

Using Solution Menu or My Printer (Windows only), you can easily get the information of the printer, or change the print settings by only clicking buttons on a screen.

With Solution Menu, you can start the software applications supplied with the printer or display the operating instructions. It also provides you with the information on troubleshooting.

With My Printer, you can display the printer properties dialog box of the printer driver. It also provides you with the information on how to take an action when you have trouble with the operation. My Printer is not available in Macintosh.

### To Start Solution Menu



Double-click  (Solution Menu) on the desktop.



Click Here: [Solution Menu](#)



Click  (Solution Menu) in the Dock.

\* The screens below are for Windows Vista.



Click the button of a function to use.



After starting Solution Menu, click  (Window size: small) on the title bar to reduce the window size.



### Note

- Install Solution Menu from the *Setup CD-ROM* when it has not been installed or has been uninstalled. To install Solution Menu, select Solution Menu in Custom Install.
- The buttons displayed on the screen may vary depending on the country or region of purchase.



- To start Solution Menu from the Start menu, select All Programs (Programs in Windows 2000), Canon Utilities, Solution Menu, then Solution Menu.



- To start Solution Menu from the command bar, select the Go menu, Applications, Canon Utilities, Solution Menu, then double-click Solution Menu.

### To Start My Printer



Double-click  (My Printer) on the desktop.



**Note**

- You can also start My Printer from Solution Menu.
  - Install My Printer from the *Setup CD-ROM* when it has not been installed or has been uninstalled. To install My Printer, select My Printer in Custom Install.
  - To start My Printer from the Start menu, select All Programs (Programs in Windows 2000), Canon Utilities, My Printer, then My Printer.
- 

[↑ Page top](#)

# Loading Paper

This section describes types of paper you can load and how to load printing paper in the Rear Tray.

## Loading Paper

[Media Types You can Use](#)

[Media Types You cannot Use](#)

[Loading Paper](#)

[Loading Envelopes](#)



[↑ Page top](#)

## Loading Paper

### Media Types You can Use



Choose papers suitable for printing, for the best print results. Canon provides you various types of paper to enhance the fun of printing, such as stickers as well as papers for photo or document. We recommend the use of Canon genuine paper for printing your important photos.

#### Media Types

#### Commercially available papers

Name of Paper <Model No.>*1	Paper Load Limit	Paper Thickness Lever	Printer Driver Setting for Media Type
Plain Paper (Recycled paper)*2	Approx. 100 sheets	Left	Plain Paper
Envelopes	5 envelopes	Right	Envelope

#### Canon genuine papers

Name of Paper <Model No.>*1	Paper Load Limit	Paper Thickness Lever	Printer Driver Setting for Media Type
For printing documents:			
Super White Paper <SW-201>	Approx. 80 sheets	Left	Plain Paper
For printing photos:			
			
Photo Paper Pro II <PR-201>*3	A4, Letter, 5" x 7" / 13 x 18 cm and 8" x 10" / 20 x 25 cm: 10 sheets	Left	Photo Paper Pro II
Glossy Photo Paper "Everyday Use" <GP-501>*3	4" x 6" / 10 x 15 cm: 20 sheets	Left	Glossy Photo Paper
Photo Paper Glossy <GP-502>*3		Left	Glossy Photo Paper
Photo Paper Plus Glossy II <PP- 201>*3		Left	Photo Paper Plus Glossy II
Photo Paper Plus Semi-gloss <SG-201>*3		Left	Photo Paper Plus Semi- gloss
Matte Photo Paper <MP-101>		Left	Matte Photo Paper
For printing business documents:			
			
High Resolution Paper <HR-101N>	80 sheets	Left	High Resolution Paper
For creating your own prints:			



T-Shirt Transfers <TR-301>	1 sheet	Right	T-Shirt Transfers
Photo Stickers <PS-101>	1 sheet	Left	Glossy Photo Paper

\*1 Paper with a Model Number is Canon genuine paper. Refer to the instruction manual supplied with the paper for detailed information on the printable side and notes on handling paper. For information on the page sizes available for each Canon genuine paper, visit our website. You may not be able to purchase some Canon genuine papers depending on the country or region of purchase. Paper is not sold in the US by Model Number. Purchase paper by name.

\*2 Proper feeding of paper may not be possible at the maximum capacity depending on the type of paper or environmental conditions (either very high or low temperature or humidity). In such cases, reduce the number of paper you load at a time to less than half (100% recycled paper can be used).

\*3 When loading paper in stacks, the print side may become marked as it is fed or paper may not feed properly. In this case, load one sheet at a time.

## ● Page Sizes

You can use the following page sizes.

In Macintosh, Choukei 3 and Choukei 4 are not available.

### Standard sizes:

- Letter (8.50 x 11.00 inches / 215.9 x 279.4 mm)
- Legal (8.50 x 14.00 inches / 215.9 x 355.6 mm)
- A5 (5.83 x 8.27 inches / 148.0 x 210.0 mm)
- A4 (8.27 x 11.69 inches / 210.0 x 297.0 mm)
- B5 (7.17 x 10.12 inches / 182.0 x 257.0 mm)
- 4" x 6" (4.00 x 6.00 inches / 10 x 15 cm)
- 4" x 8" (4.00 x 8.00 inches / 101.6 x 203.2 mm)
- 5" x 7" (5.00 x 7.00 inches / 13 x 18 cm)
- 8" x 10" (8.00 x 10.00 inches / 20 x 25 cm)
- L (3.50 x 5.00 inches / 89.0 x 127.0 mm)
- 2L (5.00 x 7.01 inches / 127.0 x 178.0 mm)
- Hagaki (3.94 x 5.83 inches / 100.0 x 148.0 mm)
- Hagaki 2 (7.87 x 5.83 inches / 200.0 x 148.0 mm)
- Comm. Env. #10 (4.12 x 9.50 inches / 104.6 x 241.3 mm)
- DL Env. (4.33 x 8.66 inches / 110.0 x 220.0 mm)
- Choukei 3 (4.72 x 9.25 inches / 120.0 x 235.0 mm)
- Choukei 4 (3.54 x 8.07 inches / 90.0 x 205.0 mm)
- Youkei 4 (4.13 x 9.25 inches / 105.0 x 235.0 mm)
- Youkei 6 (3.86 x 7.48 inches / 98.0 x 190.0 mm)
- Card (2.16 x 3.58 inches / 55.0 x 91.0 mm)
- Wide (4.00 x 7.10 inches / 101.6 x 180.6 mm)

### Non-standard sizes:

You can also specify a custom size within the following range.

- Minimum size: 2.17 x 3.58 inches / 55.0 x 91.0 mm
- Maximum size: 8.50 x 23.00 inches / 215.9 x 584.2 mm

## ● Paper Weight

17 to 28 lb / 64 to 105 gsm (plain paper except for Canon genuine paper)

Do not use heavier or lighter paper (except for Canon genuine paper), as it could jam in the printer.

## ● Notes on Storing Paper

- Take out only the necessary number of paper from the package, just before printing.
- To avoid curling, when you do not print, put unused paper back into the package and keep it on a level surface. And also, store them avoiding heat, humidity, and direct sunlight.





[↑ Page top](#)

## ■ Media Types You cannot Use

Do not use the following types of paper. Using such paper will not only produce unsatisfactory results, but can also cause the printer to jam or malfunction.

- Folded, curled, or wrinkled paper
- Damp paper
- Paper that is too thin (weighing less than 17 lb / 64 gsm)
- Paper that is too thick (plain paper, except for Canon genuine paper, weighing more than 28 lb / 105 gsm)
- Paper thinner than a postcard, including plain paper or notepad paper cut to a small size (when printing on A5 or smaller sized paper)
- Picture postcards
- Postcards affixed with photos or stickers
- Envelopes with a double flap (or sticker flaps)
- Envelopes with an embossed or treated surface
- Envelopes with pressure seals
- Envelopes whose gummed flaps are already moistened and adhesive
- Any type of paper with holes
- Paper that is not rectangular
- Paper bound with staples or glue
- Paper with adhesives
- Paper decorated with glitter, etc.



## ■ Loading Paper

### ⚠ Important

- If you cut plain paper into small paper such as 4" x 6" / 10 x 15 cm, 4" x 8" / 101.6 x 203.2 mm, 5" x 7" / 13 x 18 cm, or 2.16" x 3.58" / 55.0 x 91.0 mm (Card size) to perform trial print, it can cause paper jams.
- Always load paper in the portrait orientation (A). Loading paper in the landscape orientation (B) can cause paper jams.

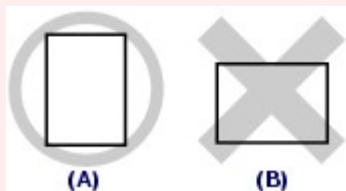

- When performing duplex printing, make sure that there is no uneven surface or no dust and stain on the area (desk, etc.) where the printed paper is ejected. If there is uneven surface or dust and stain on that area, the printing result and printer can be badly effected.

### 📖 Note

- We recommend Canon genuine photo paper for printing photos. For details on the Canon genuine paper, see [Media Types You can Use](#).
- You can use general copy paper. When printing on both sides, we recommend Canon's Super White Paper. For the page size and paper weight you can use for the printer, see [Media Types You can Use](#).

## 1. Flatten the four corners of paper before loading it.

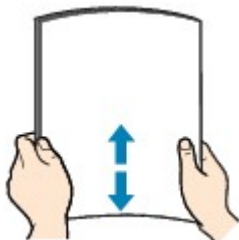

### 📖 Note

- Align the edges of paper neatly before loading. Loading paper without aligning the edges may cause paper jams.
- If paper is curled, hold the curled corners and gently bend them in the opposite direction until the paper becomes completely flat. For details on flattening curled paper, refer to the "[Troubleshooting](#)" in the on-screen manual: *Advanced Guide*.

## 2. Prepare for loading the paper.



(1) Open the Paper Support.

(2) Adjust the position of the Paper Thickness Lever.

This lever switches the clearance between the Print Head and the loaded paper to match the media type.

Set it to the left when printing on plain paper.

Set it to the right when printing on envelopes or T-shirt transfers.



#### Note

- If the corners or edges of paper are smudged, try to print with the Paper Thickness Lever set to the right. It may improve print quality.  
Reset the Paper Thickness Lever to the left when you finish printing.

### 3. Load paper.

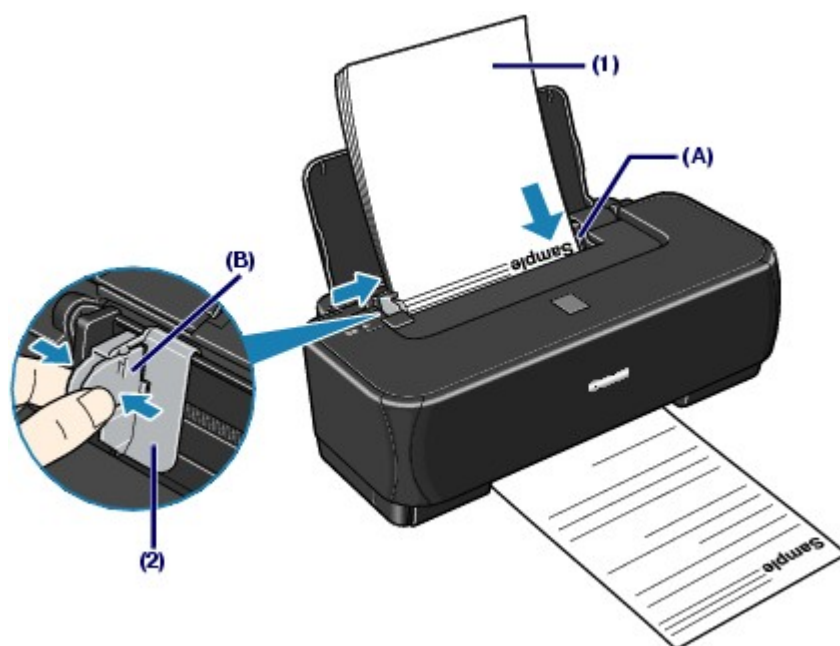

(1) Align the paper stack against the right side of the Rear Tray (A) and load it WITH THE PRINT SIDE FACING YOU and WITH THE BOTTOM UP.



#### Note

- Do not load higher than the Load Limit Mark (B).

- (2) Pinch the Paper Guide and slide it against the left side of the paper stack.  
Do not slide the Paper Guide too hard. The paper may not be fed properly.

**Note**

- The printer may make operating noise when feeding paper.

**Note****After loading paper**

- Select the size and type of the loaded paper in Page Size (or Paper Size) and Media Type in the printer driver. See [Printing Documents \(Windows\)](#) or [Printing Documents \(Macintosh\)](#).



[↑ Page top](#)

## ■ Loading Envelopes

You can print on European DL and US Comm. Env. #10-sized envelope.

The address is automatically rotated and printed according to the envelope's direction by specifying with the printer driver properly.

### ⚠ Important

- You cannot use the following envelopes.
  - Envelopes with an embossed or treated surface
  - Envelopes with a double flap (or sticker flaps)
  - Envelopes with pressure seals
  - Envelopes whose gummed flaps are already moistened and adhesive

## 1. Prepare envelopes.

- Press down on all four corners and edges of the envelopes to flatten them.

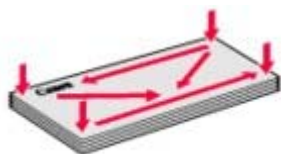

- If the envelopes are curled, hold the opposite corners and gently twist them in the opposite direction.



- If the corner of the envelope flap is folded, flatten it.
- Use a pen to press the leading edge in the inserting direction flat and sharpen the crease.

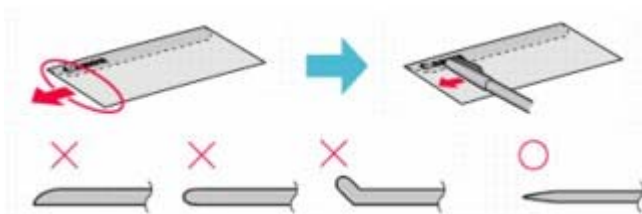

The figures above show a side view of the leading edge of the envelope.

### ⚠ Important

- The envelopes may jam in the printer if they are not flat or the edges are not aligned. Make sure that no curl or puff exceeds 0.1 inches / 3 mm.

## 2. Load the envelopes.

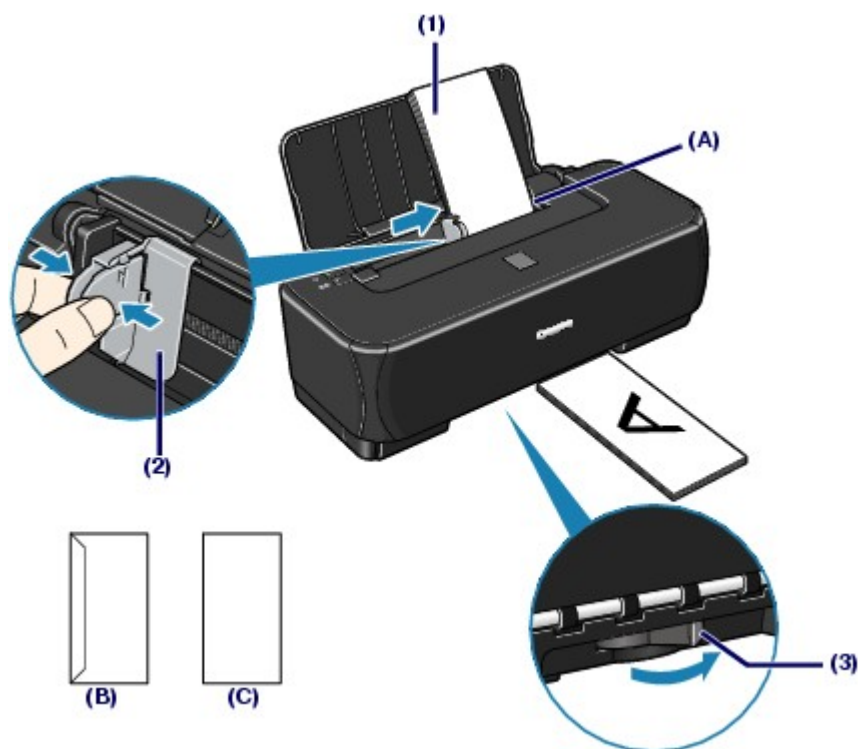

(B) Rear side

(C) Address side

**(1) Align the envelopes against the right side of the Rear Tray (A) and load it WITH THE ADDRESS SIDE FACING YOU.**

The folded flap of the envelope will be faced down on the left side.

Up to 5 envelopes can be loaded at once.

**(2) Pinch the Paper Guide and slide it against the left side of the envelopes.**

Do not slide the Paper Guide too hard. The paper may not be fed properly.

**(3) Set the Paper Thickness Lever to the right.**

Reset the Paper Thickness Lever to the left when you finish printing.

**3. Specify the settings in the printer driver.**

**(1) Select Envelope in Media Type.**

**(2) Select the size for envelopes.**



Select DL Env. or Comm. Env. #10 in Page Size.



Select DL Envelope or #10 Envelope in Paper Size.

**(3) Select Landscape in Orientation.**



**Important**

- If you do not specify Page Size (or Paper Size) or Orientation properly, the address will be printed upside down or will be turned to 90 degrees.



**Note**

- The printer may make operating noise when feeding envelopes.
- In Windows, if the print result is upside down, select Rotate 180 degrees on the Page Setup sheet in the printer properties dialog box of the printer driver.



# Routine Maintenance

This section describes how to clean the printer when the print result is faint, to replace a FINE Cartridge when it runs out, or to take an action when paper does not feed properly.

## When Printing Becomes Faint or Colors Are Incorrect

- [Printing the Nozzle Check Pattern](#)
- [Examining the Nozzle Check Pattern](#)
- [Cleaning the Print Head](#)
- [Cleaning the Print Head Deeply](#)
- [Aligning the Print Head](#)

## Replacing a FINE Cartridge

- [Checking the Ink Status](#)
- [Replacing Procedure](#)

## Cleaning the Paper Feed Roller

## Opening the Maintenance Screens

- [Opening the Printer Properties Dialog Box \(Windows\)](#)
- [Opening the Canon IJ Printer Utility \(Macintosh\)](#)





## When Printing Becomes Faint or Colors Are Incorrect

If print results are blurred or colors are not printed correctly, the print head nozzles (FINE Cartridges) are probably clogged. Follow the procedure below to print the nozzle check pattern, check the print head nozzle condition, then clean the Print Head.

If printed ruled lines are misaligned or print results are otherwise unsatisfactory, aligning the Print Head may improve print quality.

### Caution

- Do not rinse or wipe the FINE Cartridges. This can cause trouble with the FINE Cartridges.

### Note

#### Before performing maintenance

- Make sure that a FINE Cartridge has not run out of ink. See [Checking the Ink Status](#).
- Make sure that FINE Cartridges are installed properly. See [Replacing a FINE Cartridge](#).
- Make sure that the orange protective tape is removed from the bottom of a FINE Cartridge.
- If the **Alarm** lamp flashes orange, refer to the "[Troubleshooting](#)" in the on-screen manual: *Advanced Guide*.
- Increasing the print quality in the printer driver settings may improve the print result. For details, refer to the on-screen manual: *Advanced Guide*.

#### ● When the Print Results Are Blurred or Uneven:

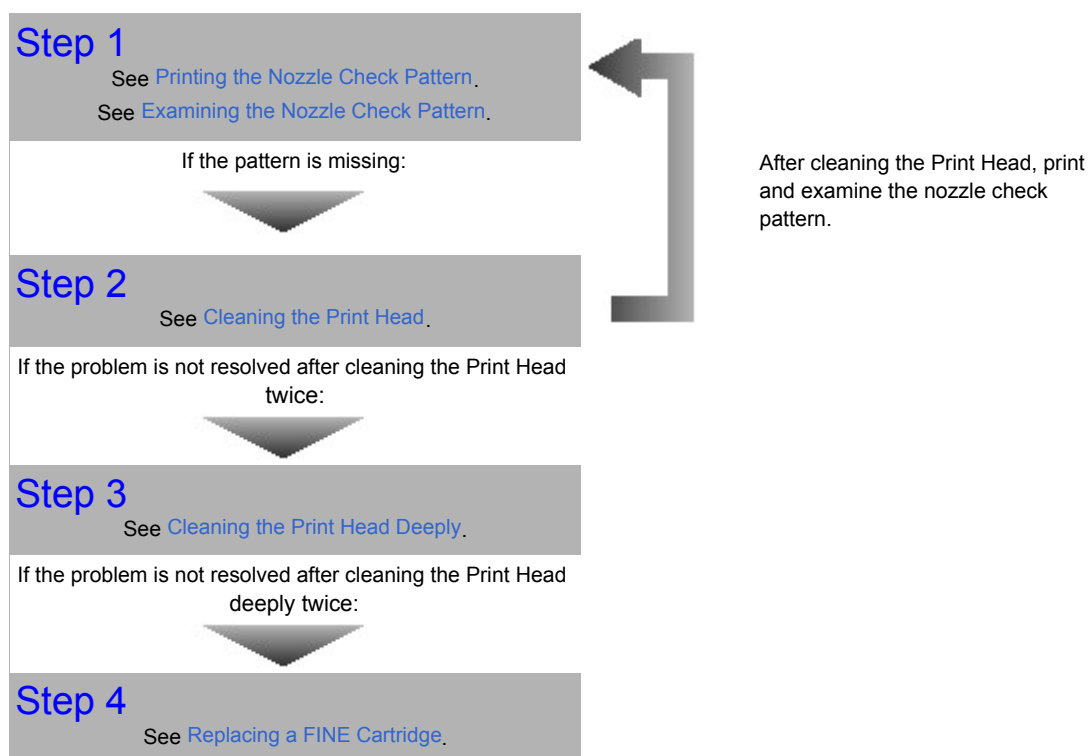

#### ● When the Print Results Are Not Even Such As the Ruled Lines Are Misaligned:

See [Aligning the Print Head](#).



## Basic Guide

■ Advanced Guide ■ Troubleshooting

Contents > Routine Maintenance > When Printing Becomes Faint or Colors Are Incorrect > Printing the Nozzle Check Pattern

## ■ Printing the Nozzle Check Pattern

Print the nozzle check pattern to determine whether the ink ejects properly from the print head nozzles.

### You need to prepare: a sheet of A4 or Letter-sized plain paper

#### Note

- If the remaining ink level is low, the nozzle check pattern will not be printed correctly. Replace the FINE Cartridge whose ink is low.  
See [Replacing a FINE Cartridge](#).

#### Windows

1. Make sure that the power is turned on and a sheet of A4 or Letter-sized plain paper are loaded in the Rear Tray.

Set the Paper Thickness Lever to the left. See [Front View](#).

2. Open the printer properties dialog box.

See [Opening the Printer Properties Dialog Box \(Windows\)](#).

3. Print the nozzle check pattern.



- (1) Click the Maintenance tab.

- (2) Click Nozzle Check.

- (3) Confirm the displayed message and click Print Check Pattern.

The nozzle check pattern will be printed. Do not open the Front Cover while printing is in progress.

#### Note

- Clicking Initial Check Items displays the items to be checked before printing the pattern.

4. Examine the pattern.

See [Examining the Nozzle Check Pattern](#).

#### Macintosh

1. Make sure that the power is turned on and a sheet of A4 or Letter-sized plain paper

are loaded in the Rear Tray.

Set the Paper Thickness Lever to the left. See [Front View](#).

## 2. Open the Canon IJ Printer Utility dialog box.

See [Opening the Canon IJ Printer Utility \(Macintosh\)](#).

## 3. Print the nozzle check pattern.



(1) Select Test Print in the pop-up menu.

(2) Click Nozzle Check.

(3) Confirm the displayed message and click Print Check Pattern.

The nozzle check pattern will be printed. Do not open the Front Cover while printing is in progress.



### Note

- Clicking Initial Check Items displays the items to be checked before printing the pattern.

## 4. Examine the pattern.

See [Examining the Nozzle Check Pattern](#).



## ■ Examining the Nozzle Check Pattern

Examine the nozzle check pattern, and clean the Print Head if necessary.

1. Check if lines are missing in the pattern (1), or if there are white streaks in the pattern (2).

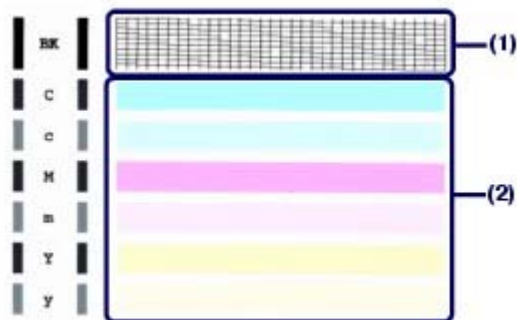

- (1) Check if lines are missing in this pattern.

If yes, the cleaning is required.



(A) Good

(B) Bad (Lines are missing)

- (2) Check if there are white streaks in this pattern.

If yes, the cleaning is required.



(A) Good

(B) Bad (White streaks present)

2. Take necessary action.

- When the cleaning is not required

Click Exit (Windows) or Quit (Macintosh) on the Pattern Check dialog box to exit nozzle check pattern examination.

- When the cleaning is required



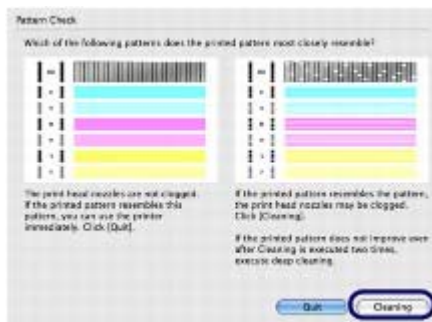
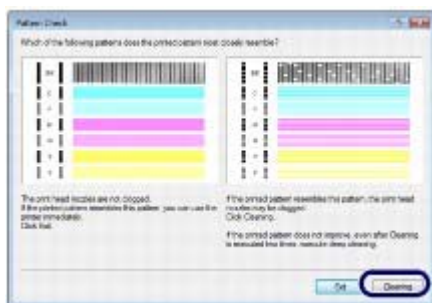

Click Cleaning.

Make sure that a sheet of A4 or Letter-sized plain paper are loaded in the Rear Tray, and then proceed to the procedure below.



Go to the procedure of (3) in step 3.



Go to the procedure of (3) in step 3.



[↑ Page top](#)

## ■ Cleaning the Print Head

Clean the Print Head if lines are missing or if there are white streaks in the printed nozzle check pattern. Cleaning unclogs the nozzles and restores the print head condition. Cleaning the Print Head consumes ink, so clean the Print Head only when necessary.

### You need to prepare: a sheet of A4 or Letter-sized plain paper

#### Windows

If you click Cleaning on the Pattern Check dialog box that appears after printing the nozzle check pattern, the printer starts cleaning the Print Head. Make sure that a sheet of A4 or Letter-sized plain paper are loaded in the Rear Tray, then go to the procedure of (3) in step 3.

### 1. Make sure that the power is turned on and a sheet of A4 or Letter-sized paper are loaded in the Rear Tray.

Set the Paper Thickness Lever to the left. See [Front View](#).

### 2. Open the printer properties dialog box.

See [Opening the Printer Properties Dialog Box \(Windows\)](#).

### 3. Clean the Print Head.

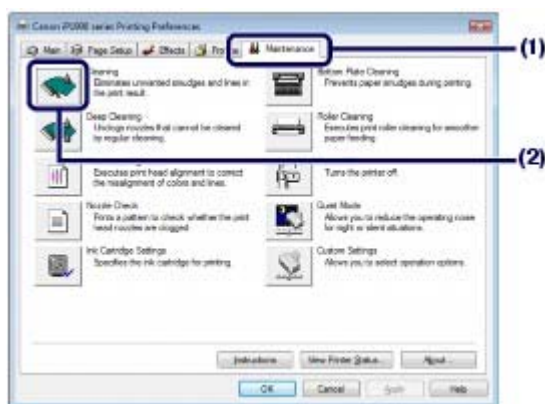

#### (1) Click the Maintenance tab.

#### (2) Click Cleaning.

The printer starts cleaning the Print Head when the **Power** lamp starts flashing green.

Do not perform any other operations until the printer completes the cleaning of the Print Head. This takes about 1 minute.

#### (3) Confirm the displayed message and click Print Check Pattern.

The nozzle check pattern will be printed.

Do not perform any other operations until the printer completes the printing of the nozzle check pattern.

### 4. Check the printed nozzle check pattern.

See [Examining the Nozzle Check Pattern](#).



#### Note

- If the problem is not resolved after cleaning the Print Head twice, clean the Print Head deeply. See [Cleaning the Print Head Deeply](#).

## Macintosh

If you click **Cleaning** on the **Pattern Check** dialog box that appears after printing the nozzle check pattern, the printer starts cleaning the **Print Head**. Make sure that a sheet of **A4** or **Letter-sized** plain paper are loaded in the **Rear Tray**, then go to the procedure of (3) in step 3.

1. Make sure that the power is turned on and a sheet of **A4** or **Letter-sized** paper are loaded in the **Rear Tray**.

Set the **Paper Thickness Lever** to the left. See [Front View](#).

2. Open the **Canon IJ Printer Utility** dialog box.

See [Opening the Canon IJ Printer Utility \(Macintosh\)](#).

3. Clean the **Print Head**.

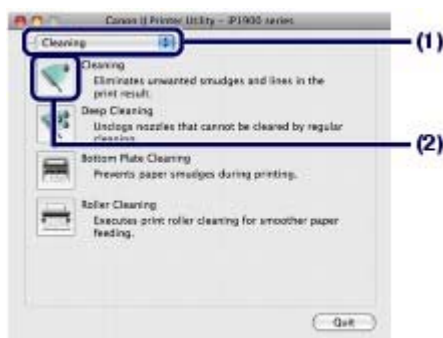

- (1) Make sure that **Cleaning** is selected in the pop-up menu.

- (2) Click **Cleaning**.

- (3) Confirm the displayed message and click **OK**.

The printer starts cleaning the **Print Head** when the **Power** lamp starts flashing green.

Do not perform any other operations until the printer completes the cleaning of the **Print Head**. This takes about 1 minute.



### Note

- Clicking **Initial Check Items** displays the items to be checked before cleaning.

- (4) Confirm the displayed message and click **Print Check Pattern**.

The nozzle check pattern is printed.

Do not perform any other operations until the printer completes the printing of the nozzle check pattern.

4. Check the printed nozzle check pattern.

See [Examining the Nozzle Check Pattern](#).



### Note

- If the problem is not resolved after cleaning the **Print Head** twice, clean the **Print Head** deeply. See [Cleaning the Print Head Deeply](#).



[Contents](#) > [Routine Maintenance](#) > [When Printing Becomes Faint or Colors Are Incorrect](#) > [Cleaning the Print Head Deeply](#)

## ■ Cleaning the Print Head Deeply

If print quality does not improve by standard Print Head Cleaning, clean the Print Head deeply. Print Head Deep Cleaning consumes more ink than standard Print Head Cleaning, so clean the Print Head deeply only when necessary.

### Windows

1. Make sure that the power is turned on.

2. Open the printer properties dialog box.

See [Opening the Printer Properties Dialog Box \(Windows\)](#) .

3. Clean the Print Head deeply.



(1) Click the Maintenance tab.

(2) Click Deep Cleaning.

(3) Confirm the displayed message and click Execute.



#### Note

- Clicking Initial Check Items displays the items to be checked before cleaning the Print Head deeply.

(4) Confirm the displayed message and click OK.

The printer starts cleaning the Print Head deeply when the **Power** lamp starts flashing green.

Do not perform any other operations until the printer completes the deep cleaning of the Print Head. This takes about 1 or 2 minutes.

4. Print the nozzle check pattern to check the print head condition.

See [Printing the Nozzle Check Pattern](#).



#### Note

- If the problem is not resolved, clean the Print Head deeply again.
- If this does not solve the problem, ink may have run out. Replace the FINE Cartridge with a new one. See [Replacing a FINE Cartridge](#).

### Macintosh

1. Make sure that the power is turned on.



## 2. Open the Canon IJ Printer Utility dialog box.

See [Opening the Canon IJ Printer Utility \(Macintosh\)](#).

## 3. Clean the Print Head deeply.



(1) Make sure that Cleaning is selected in the pop-up menu.

(2) Click Deep Cleaning.

(3) Confirm the displayed message and click OK.

The printer starts cleaning the Print Head deeply when the **Power** lamp starts flashing green.

Do not perform any other operations until the printer completes the deep cleaning of the Print Head. This takes about 1 or 2 minutes.



### Note

- Clicking Initial Check Items displays the items to be checked before cleaning the Print Head deeply.

## 4. Print the nozzle check pattern to check the print head condition.

See [Printing the Nozzle Check Pattern](#).



### Note

- If the problem is not resolved, clean the Print Head deeply again.
- If this does not solve the problem, ink may have run out. Replace the FINE Cartridge with a new one. See [Replacing a FINE Cartridge](#).



## Aligning the Print Head

If printed ruled lines are misaligned or print results are not even, adjust the print head position.

### You need to prepare: a sheet of A4 or Letter-sized plain paper



1. Make sure that the power is turned on and a sheet of A4 or Letter-sized plain paper are loaded in the Rear Tray.

Set the Paper Thickness Lever to the left. See [Front View](#).

2. Open the printer properties dialog box.

See [Opening the Printer Properties Dialog Box \(Windows\)](#) .

3. Print the print head alignment pattern.



- (1) Click the Maintenance tab.

- (2) Click Print Head Alignment.

- (3) Confirm the displayed message, and click OK.

The print head alignment pattern will be printed. Do not open the Front Cover while printing is in progress. Printing takes about 3 minutes to complete.

- (4) After the pattern below is printed, make sure that the pattern is printed properly, and click Yes.

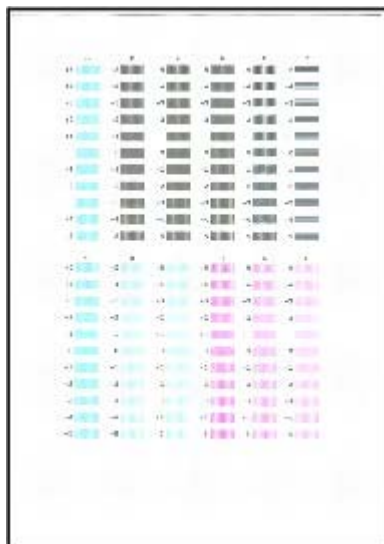

#### 4. Adjust the print head position.

- (1) Look at the printout and select the pattern number in column A that has the least noticeable streaks.

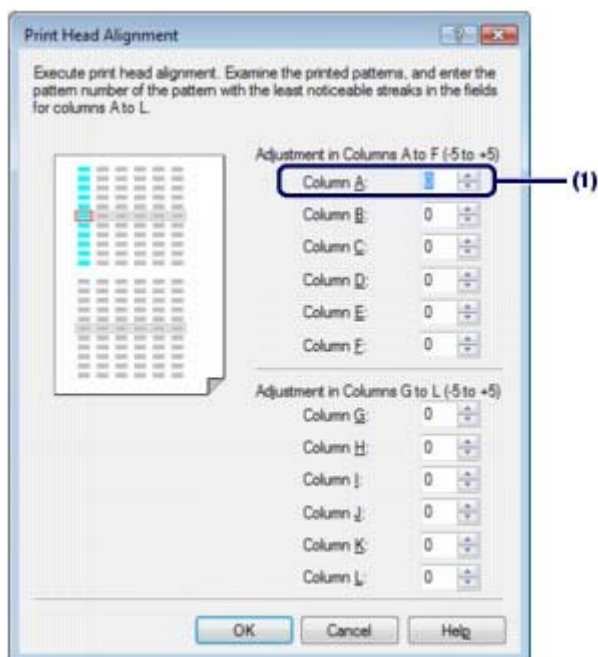

#### Note

- If it is difficult to pick the best pattern, pick the setting that produces the least noticeable white streaks.



(A)



(B)



(C)



(D)

(A) Less noticeable vertical white streaks

(B) Noticeable vertical white streaks

(C) Less noticeable horizontal white streaks

(D) Noticeable horizontal white streaks

- (2) Repeat the procedure until you finish selecting the pattern number for column L, and click OK.

- (3) Confirm the displayed message, and click OK.

#### Macintosh

1. Make sure that the power is turned on and a sheet of A4 or Letter-sized plain paper are loaded in the Rear Tray.

Set the Paper Thickness Lever to the left. See [Front View](#).

2. Open the Canon IJ Printer Utility dialog box.

See [Opening the Canon IJ Printer Utility \(Macintosh\)](#).

3. Print the print head alignment pattern.

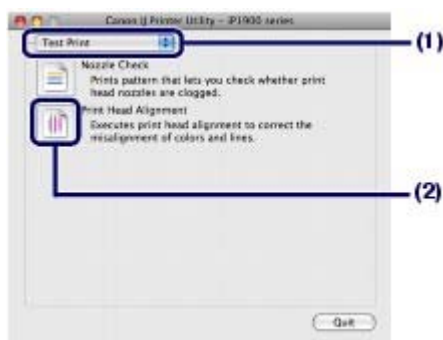

- (1) Select Test Print in the pop-up menu.
- (2) Click Print Head Alignment.
- (3) Confirm the displayed message, and click OK.

The print head alignment pattern will be printed. Do not open the Front Cover while printing is in progress. Printing takes about 3 minutes to complete.

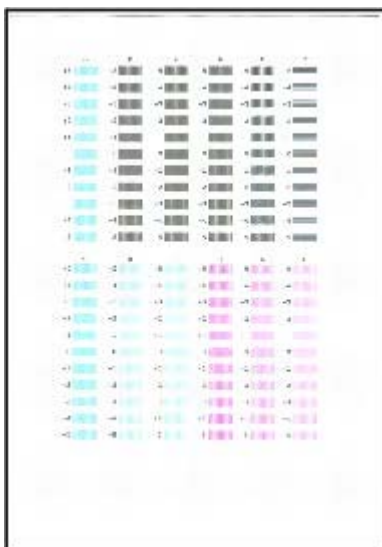

#### 4. Adjust the print head position.

- (1) Look at the printout and select the pattern number in column A that has the least noticeable streaks.

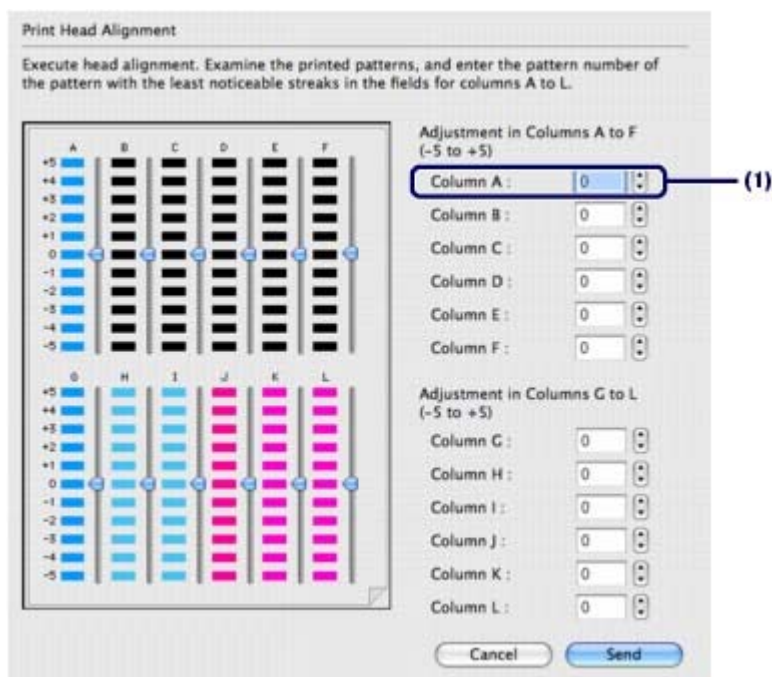

- If it is difficult to pick the best pattern, pick the setting that produces the least noticeable white streaks.
- 



(A)



(B)



(C)



(D)

(A) Less noticeable vertical white streaks

(B) Noticeable vertical white streaks

(C) Less noticeable horizontal white streaks

(D) Noticeable horizontal white streaks

- (2)** Repeat the procedure until you finish selecting the pattern number for column L, and, click Send.



[↑ Page top](#)

## Replacing a FINE Cartridge

When ink runs out while printing is in progress, the **Alarm** lamp flashes orange four times and the error message will appear on your computer screen. Make sure which ink has run out and replace it with a new FINE Cartridge.

### Note

- If the error message appears, confirm the displayed message and take an appropriate action. For details, refer to the "Four Flashes: Ink has run out." of the "Alarm Lamp Flashes Orange" in the "[Troubleshooting](#)" of the on-screen manual: *Advanced Guide*.
- For information on compatible FINE Cartridges, refer to the printed manual: *Getting Started*.

## ■ Checking the Ink Status

You can check the ink status of each FINE Cartridge on the printer status monitor (Windows) and Canon IJ Printer Utility (Macintosh).

### Note

- The ink level detector is mounted on the printer to detect the remaining ink level. The printer considers as ink is full when a new FINE Cartridge is installed, and then starts to detect a remaining ink level. If you install a used FINE Cartridge, the indicated ink level of it may not be correct. In such case, refer to the ink level information only as a guide.

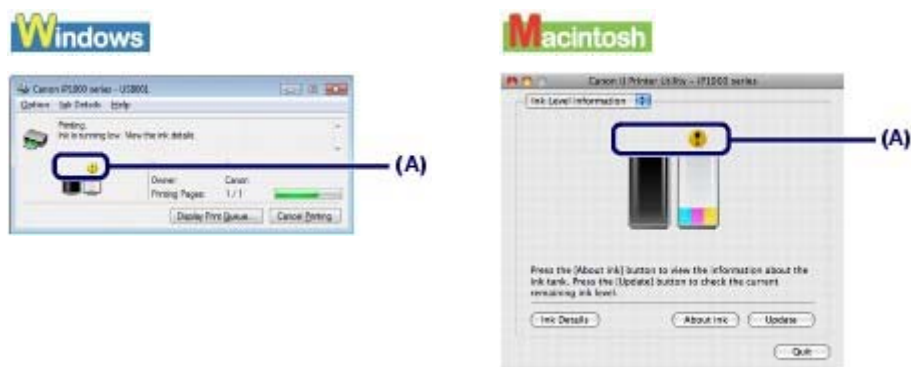

(A) Check if any symbol appears on the screen.

- Ink with (Ink low) is running low. You can continue printing for a while, but we recommend you to have a new FINE Cartridge available.

Follow the procedure below to open each of the confirmation screens.

### Windows

- (1) Open the printer properties dialog box.  
See [Opening the Printer Properties Dialog Box \(Windows\)](#) .
- (2) Click the Maintenance tab, and View Printer Status.  
To confirm the ink level information, click the Ink Details menu.

### Note

- You can also display the printer status monitor by clicking Canon XXX (where " XXX" is your printer's name) which appears on the taskbar during printing.

### Macintosh

- (1) Open the Canon IJ Printer Utility.  
See [Opening the Canon IJ Printer Utility \(Macintosh\)](#).
- (2) Select Ink Level Information in the pop-up menu.  
To confirm the ink level information, click Ink Details.



[↑ Page top](#)

## ■ Replacing Procedure

When FINE Cartridges run out of ink, follow the procedure below to replace them.

### ⚠ Important

#### Handling FINE Cartridges

- Do not touch the electrical contacts (A) or print head nozzles (B) on a FINE Cartridge. The printer may not print out properly if you touch it.

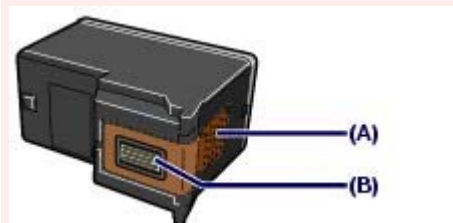

- To maintain optimal printing quality, we recommend the use of specified Canon brand FINE Cartridges. Refilling ink is not recommended.
- If you remove a FINE Cartridge, replace it immediately. Do not leave the printer with FINE Cartridges removed.
- Replace empty cartridges with new ones. If you insert FINE Cartridges that have been removed once, the printer may not print out properly due to some reasons such as clogging of the nozzles. Furthermore, with such cartridges, the Low Ink Warning may not appear properly.
- To maintain optimal print quality, install FINE Cartridges in the printer within the date indicated on the package box. And also use up FINE Cartridges within six months after the installation (We recommend you to put down the date when installing them).

### 📖 Note

- If a FINE Cartridge runs out of ink, you can print with either Color or Black FINE Cartridge, in whichever ink remains, only for a while. However the print quality may be reduced compared to when printing with both cartridges. We recommend to use new FINE cartridges in order to obtain optimum qualities. Even when printing with one ink only, print with leaving the empty FINE Cartridge installed. If either of the Color FINE Cartridge or Black FINE Cartridge is not installed, an error occurs and the printer cannot print. For information on how to configure this setting, refer to the on-screen manual: [Advanced Guide](#).
- Color ink may be consumed even when printing a black-and-white document or when black-and-white printing is specified. Every ink is also consumed in Print Head Cleaning and Print Head Deep Cleaning, which may be necessary to maintain the printer's performance. When ink has run out, replace the FINE Cartridge immediately with a new one.

## 1. Make sure that the power is turned on, and open the Front Cover.

The FINE Cartridge Holder moves to the replacement position.

### ⚠ Caution

- Do not hold the FINE Cartridge Holder to stop or move it forcibly.
- Do not touch the metallic parts or other parts inside the printer.





**Important**

- If the Front Cover is left open for more than 10 minutes, the FINE Cartridge Holder moves to the right. In this case, close and reopen the Front Cover.

**2. Remove the empty FINE Cartridge.**

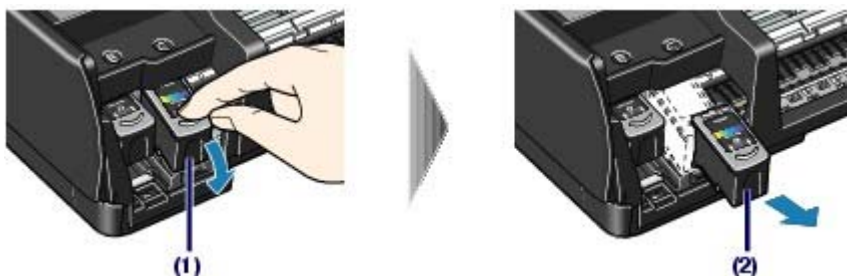

(1) Push down the FINE Cartridge.

(2) Remove the FINE Cartridge.

**Important**

- Handle FINE Cartridges carefully to avoid staining of clothing or the surrounding area.
- Discard empty FINE Cartridges according to the local laws and regulations regarding disposal of consumables.

**3. Prepare the new FINE cartridge.**

Take the new FINE Cartridge out of its package and remove the orange protective tape (A) gently.

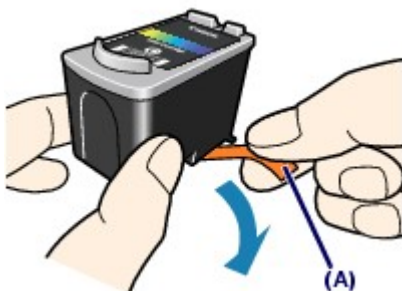

**Important**

- If you shake a FINE Cartridge, ink may spill out and stain your hands or the surrounding area. Handle FINE Cartridges carefully.
- Be careful not to stain your hands or surrounding area with ink on the removed protective tape.
- Do not reattach the protective tape once you have removed it. Discard it according to the local laws and regulations regarding disposal of consumables.
- Do not touch the electrical contacts or print head nozzles on a FINE Cartridge. The printer may

not print properly if you touch it.

#### 4. Install the FINE Cartridge.

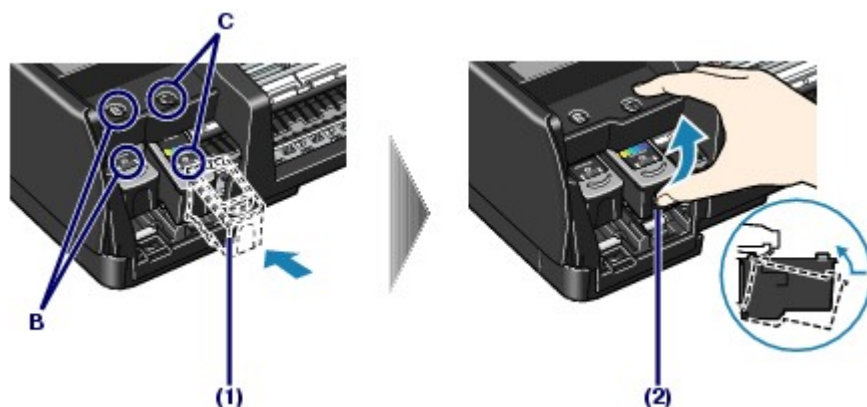

**(1)** Insert a new FINE Cartridge all the way into the appropriate slot.

The Black FINE Cartridge should be installed into the left slot (B) and the Color FINE Cartridge should be into the right slot (C).

**(2)** Push up the FINE Cartridge until it clicks into place.

**Important**

- The printer cannot print unless both the Black and Color FINE Cartridges are installed. Be sure to install both the FINE Cartridges.

#### 5. Close the Front Cover.

**Note**

- If the **Alarm** lamp still flashes orange after the Front Cover is closed, refer to the "[Troubleshooting](#)" in the on-screen manual: *Advanced Guide*.
- When you start printing after replacing the FINE Cartridge, the printer starts cleaning the Print Head automatically. Do not perform any other operations until the printer completes the cleaning of the Print Head. The **Power** lamp flashes green during cleaning.
- If the printed ruled lines are misaligned or the print head position is misaligned, align the print head position. See [Aligning the Print Head](#).



## Cleaning the Paper Feed Roller

If the Paper Feed Roller is dirty or paper powder is attached to it, paper may not be fed properly. In this case, clean the Paper Feed Roller. Cleaning will wear out the Paper Feed Roller, so perform this only when necessary.

### You need to prepare: three sheets of A4 or Letter-sized plain paper



1. Make sure that the power is turned on, and remove any paper from the Rear Tray.
2. Open the printer properties dialog box.  
See [Opening the Printer Properties Dialog Box \(Windows\)](#) .
3. Clean the Paper Feed Roller.

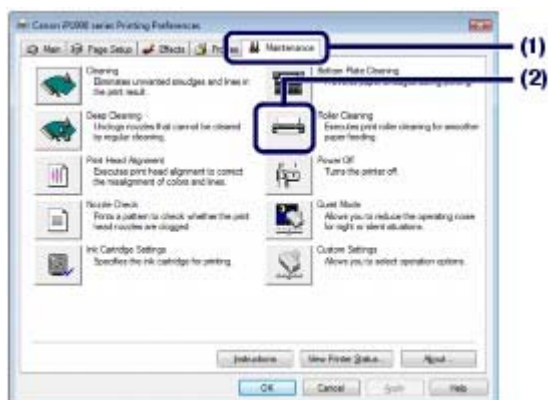

- (1) Click the Maintenance tab.
- (2) Click Roller Cleaning.
- (3) Confirm the displayed message, and click OK.  
The Paper Feed Roller will rotate as they clean.
4. Make sure that the Paper Feed Roller stops rotating. When the message appears, load paper.  
Load three sheets of A4 or Letter-sized plain paper in the Rear Tray.  
Set the Paper Thickness Lever to the left. See [Front View](#).
5. Confirm the displayed message, and click OK.  
The paper that is loaded in the printer will feed through the printer and be ejected.  
Do not perform any other operations until the printer completes the cleaning of the Paper Feed Roller.
6. When the completion message appears, click OK.

If the problem is not resolved, turn off the printer, disconnect the power plug, and then wipe the Paper Feed Roller (A) located on the right side inside the Rear Tray with a moistened cotton swab or the like. Rotate the roller manually in the direction of the arrow (B) as you clean it. Do not touch the roller with your fingers; rotate it with the cotton swab. If this does not solve the problem, contact your Canon service representative.

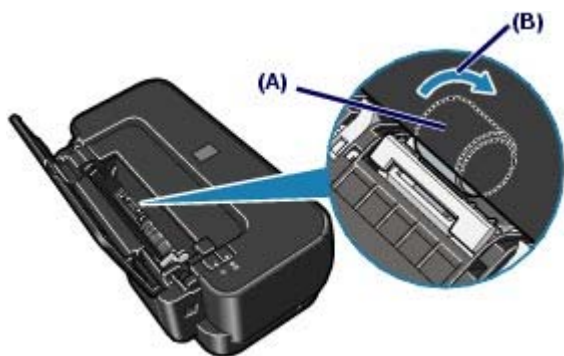

## Macintosh

1. Make sure that the power is turned on, and remove any paper from the Rear Tray.
2. Open the Canon IJ Printer Utility dialog box.  
See [Opening the Canon IJ Printer Utility \(Macintosh\)](#).
3. Clean the Paper Feed Roller.



- (1) Make sure that Cleaning is selected in the pop-up menu.
  - (2) Click Roller Cleaning.
  - (3) Confirm the displayed message, and click OK.  
The Paper Feed Roller will rotate as they clean.
4. Make sure that the Paper Feed Roller stops rotating. When the message appears, load paper.  
Load three sheets of A4 or Letter-sized plain paper in the Rear Tray.  
Set the Paper Thickness Lever to the left. See [Front View](#).
  5. Confirm the displayed message, and click OK.  
The paper that is loaded in the printer will feed through the printer and be ejected.  
Do not perform any other operations until the printer completes the cleaning.  
If the problem is not resolved, turn off the printer, disconnect the power plug, and then wipe the Paper Feed Roller (A) located on the right side inside the Rear Tray with a moistened cotton swab or the like. Rotate the roller manually in the direction of the arrow (B) as you clean it. Do not touch the roller with your fingers; rotate it with the cotton swab. If this does not solve the problem, contact your Canon service representative.

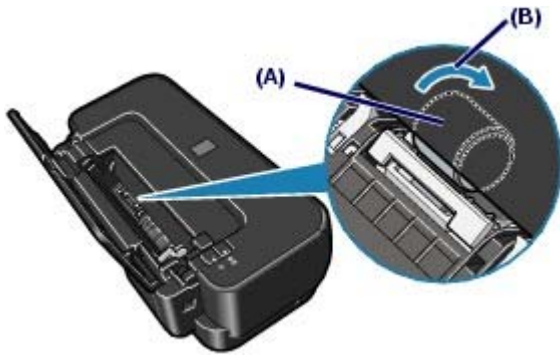

[↑ Page top](#)

## Opening the Maintenance Screens

You can maintain the printer from the printer properties dialog box (Windows) or Canon IJ Printer Utility (Macintosh).

### ■ Opening the Printer Properties Dialog Box (Windows)

#### 1. Click Control Panel, and Printer under Hardware and Sound.

In Windows XP, click Control Panel, Printers and Other Hardware, then Printers and Faxes.

In Windows 2000, click Control Panel, and Printers.

#### 2. Right-click the Canon XXX icon (where "XXX" is your printer's name), and select Printing Preferences.

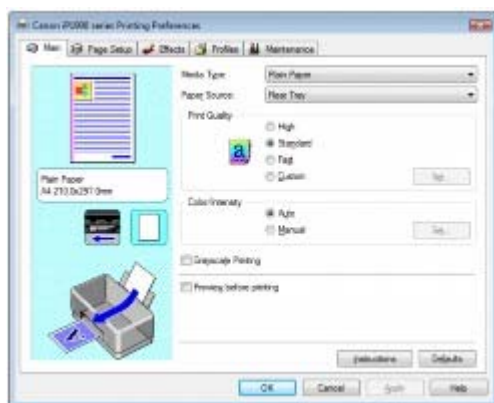

The printer properties dialog box opens.



#### Note

- You can also open the printer properties dialog box from your software application or My Printer on a desktop.

Refer to the on-screen manual: [Advanced Guide](#).

### ■ Opening the Canon IJ Printer Utility (Macintosh)

#### 1. Open System Preferences, and click Print & Fax.

#### 2. Select your printer's name in Printers, and click Open Print Queue.

The list of printer jobs appears.

#### 3. Click Utility.

The print list dialog box appears.

#### 4. Select your printer's name in the Product list, and click Maintenance.

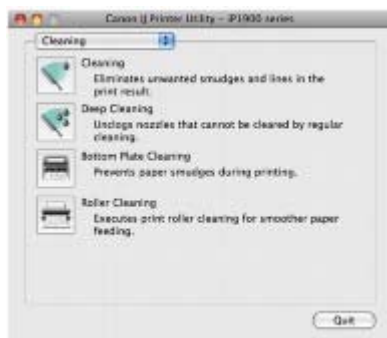

The Canon IJ Printer Utility starts up.



#### Note

- You can also open Canon IJ Printer Utility by the procedure below.  
Select Applications from the Go menu, double-click the Utilities folder, then double-click Printer Setup Utility.  
Refer to the on-screen manual: [Advanced Guide](#).



[↑ Page top](#)

# Appendix

[Safety Precautions](#)

[Legal Limitations on Use of Your Product and Use of Images](#)

[Tips on How to Use Your Printer](#)



[↑ Page top](#)





## ⚠ Safety Precautions

Please read the safety warnings and cautions provided in this manual to ensure that you use the printer safely. Do not attempt to use the printer in any way not described in this manual. It causes unexpected accident, fire, or electrical shock.

### ⚠ Warning

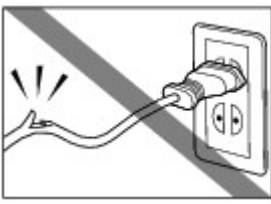
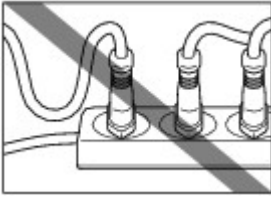
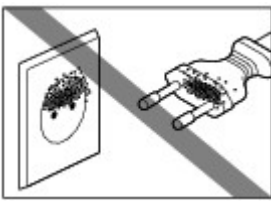

- You may cause an electric shock, fire, or damage the printer if you ignore any of these safety precautions.

<p><b>Choosing a location</b></p>	<p><b>Do not place the printer close to flammable solvents such as alcohol or thinners.</b></p>
<p><b>Power supply</b></p>	<p><b>Never attempt to plug in or unplug the printer from the power supply when your hands are wet.</b></p> <p><b>Always push the plug all the way into the power outlet.</b></p> <div data-bbox="359 772 630 974">  <p><b>Never damage, modify, stretch or excessively bend or twist the power cord. Do not place heavy objects on the power cord.</b></p> </div> <div data-bbox="359 996 630 1198">  <p><b>Never plug the printer into a power socket that is shared with other equipment (extension lead/cord, 2- or 3-way adapter, etc.).</b></p> </div> <p><b>Never use the printer if the power cord is bundled or knotted.</b></p> <p><b>If you detect smoke, unusual smells or strange noises around the printer, immediately unplug the printer at the power supply and call for service.</b></p> <div data-bbox="359 1366 630 1568">  <p><b>Periodically, unplug the printer and use a dry cloth to wipe off any dust or dirt collected on the plug and the power outlet. If the printer is placed at a location exposed to a lot of dust, smoke, or high humidity, the dust collected on the plug absorbs moisture and may cause insulation failure and fire.</b></p> </div> <p><b>If you hear thunder, disconnect the power supply of the printer and refrain from using it. Leaving the printer plugged in may cause fire, electric shock, or damage to the printer, depending on the thunder storm.</b></p> <p><b>Use the power cable included with the printer.</b></p>
<p><b>Cleaning the printer</b></p>	<div data-bbox="359 1825 630 2027">  <p><b>Use a damp cloth to clean the printer. Never use flammable solvents such as alcohol, benzene or thinners.</b></p> <p>If flammable solvents come in contact with electrical components inside the printer, it could cause a fire or electric shock.</p> </div> <p><b>Always unplug the printer from the power outlet before cleaning the printer.</b></p> <p>If you accidentally switch the printer on while cleaning it, you could injure yourself or damage the printer.</p>

<b>Maintaining the printer</b>	<p><b>Do not attempt to disassemble or modify the printer. There are no user serviceable parts inside the printer.</b></p> <p>The printer contains high-voltage components. Never attempt any maintenance procedure not described in this guide.</p>
<b>Working around the printer</b>	<p><b>Do not use highly flammable sprays near the printer.</b></p> <p>This could cause a fire or electric shock if the spray comes into contact with electrical components inside the printer.</p>

**⚠ Caution**

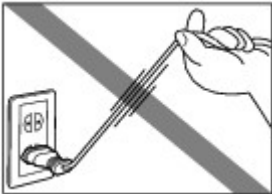
● You may cause injury or damage the printer if you ignore any of these safety precautions.

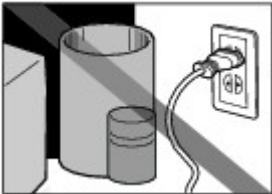
<b>Choosing a location</b>	<p><b>Do not install the printer in a location that is unstable or subject to excessive vibration.</b></p>
	<p><b>Do not install the printer in locations that are very humid or dusty, in direct sunlight, outdoors, or close to a heating source.</b></p> <p><b>To avoid the risk of fire or electric shocks, install the printer in a location with an ambient temperature range of 5°C to 35°C (41°F to 95°F) and humidity of 10% to 90% (condensation free).</b></p>
	<p><b>Do not place the printer on a thick rug or carpet.</b></p>
	<p><b>Do not place the printer with its back attached to the wall.</b></p>
<b>Power supply</b>	 <p><b>Never remove the plug by pulling on the cord.</b></p>
	 <p><b>Do not use an extension lead/cord.</b></p>
	 <p><b>Ensure that the area around the power outlet is kept clear at all times so you can easily unplug the power cord if necessary.</b></p>
<b>Working around the printer</b>	<p><b>Never put your hands or fingers in the printer while it is printing.</b></p>
	<p><b>When moving the printer, carry the printer at both ends.</b></p>
	<p><b>Do not place any object on the printer.</b></p>
	<p><b>Do not place metal objects (paper clips, staples, etc.) or containers of flammable solvents (alcohol, thinners, etc.) on top of the printer.</b></p>
	<p><b>If any foreign object (metal or liquid) fall into the printer, unplug the power cord and call for service.</b></p>
	<p><b>Do not transport or store the printer on a slant, vertically or upside-down, as the ink may leak and damage the printer.</b></p>
<b>FINE Cartridges (Ink Cartridges)</b>	<p><b>Keep FINE Cartridges (Ink Cartridges) out of the reach of children.</b></p> <p>In case ink is accidentally licked or swallowed, rinse out mouth or give one or two glasses of water to drink.</p>

If irritation or discomfort occurs, obtain medical advice immediately.

**In case ink gets in contact with eyes, rinse with water immediately.**

**In case ink gets in contact with skin, wash with soap and water immediately.**

If irritation to eyes or skin persists, obtain medical advice immediately.

**Do not shake FINE Cartridges (Ink Cartridges).**

Ink may spill out and stain clothing or the surrounding area.

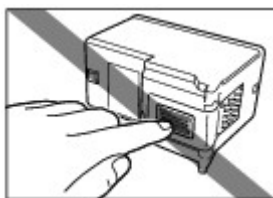

**Never touch the electrical contacts or print head nozzles on a FINE Cartridge (Ink Cartridge) after printing.**

The metal parts may be very hot and could cause burns.

**Do not throw FINE Cartridges (Ink Cartridges) into fire.**

**Do not attempt to disassemble or modify the FINE Cartridges.**

**Do not handle the FINE Cartridges roughly such as applying them excessive pressure or dropping them.**

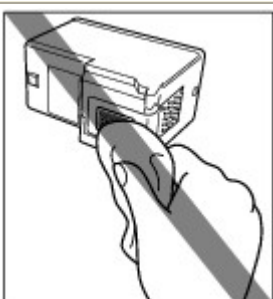

**Do not rinse or wipe the FINE Cartridges.**

**Once you have installed the FINE Cartridges, do not remove them unnecessarily.**

● **Note when you place the printer near other electrical appliances such as fluorescent lamps**

Place the printer at least 5.91 inches / 15 cm away from other electrical appliances such as fluorescent lamps. If the printer is placed closer to those, it may not be able to work properly due to fluorescent noises.

● **When you turn off the power**

When you turn off the power, always press the **Power** button and be sure that the **Power** lamp (in green) has gone out. If you disconnect the power plug from the power outlet when the **Power** lamp flashes or is lit, the Print Head cannot be protected and you may not be able to print later.



## Legal Limitations on Use of Your Product and Use of Images

It may be unlawful to print the following documents.

The list provided is non-exhaustive. When in doubt, check with a legal representative in your jurisdiction.

- Paper money
- Money orders
- Certificates of deposit
- Postage stamps (canceled or uncanceled)
- Identifying badges or insignias
- Selective service or draft papers
- Checks or drafts issued by governmental agencies
- Motor vehicle licenses and certificates of title
- Traveler's checks
- Food stamps
- Passports
- Immigration papers
- Internal revenue stamps (canceled or uncanceled)
- Bonds or other certificates of indebtedness
- Stock certificates
- Copyrighted works/works of art without permission of copyright owner



[↑ Page top](#)

## Tips on How to Use Your Printer

This section introduces the tips on how to use your printer and for printing with optimal quality.

### ■ Ink is used for various purposes.

#### ● How is ink used for various purposes other than printing?

Ink may be used for purposes other than printing. Ink is not only used for printing, but also for cleaning the Print Head to maintain the optimal printing quality.

The printer has the function to automatically clean the ink jet nozzles to prevent clogging. In the cleaning procedure, ink is pumped out from the nozzles. Used ink for nozzle cleaning is limited to a small amount.

#### ● Important

- The ink pumped out from the nozzles, such as when cleaning the Print Head, is absorbed by ink absorber in the printer. The ink absorber needs to be replaced when it is full. You cannot replace it by yourself. When the error message appears, contact your Canon service representative as soon as possible.

Refer to the "[Troubleshooting](#)" in the on-screen manual: *Advanced Guide*.

#### ● Does black-and-white printing use color ink?

The use of color or black ink varies depending on the color of image to be printed or the contents of document. Black-and-white printing may also use color ink. So, color ink is consumed even when printing in black-and-white.

### ■ Printing on special paper: How to print with optimal quality!?

#### ● Tip!: Check the printer status before printing!

##### ● Is the Print Head ok?

If print head nozzles are clogged, print will be faint and papers will be wasted. Print the nozzle check pattern to check the Print Head.

See [When Printing Becomes Faint or Colors Are Incorrect](#) .

##### ● Is the inside of the printer smeared with ink?

After printing large quantities of paper or performing borderless printing, the area where papers go through may get smeared with ink. Clean the inside of your printer with Bottom Plate Cleaning.

Refer to the on-screen manual: [Advanced Guide](#).

#### ● Tip!: Check how to load the paper correctly!

##### ● Is the paper loaded in the correct orientation?



To load paper in the Rear Tray, load paper with the printing side facing you.

### ● Is the paper curled?

The curled paper causes paper jam. Flatten the curled paper, then reload it.

Refer to the "[Troubleshooting](#)" in the on-screen manual: *Advanced Guide*.

### ● Tip!: After loading paper, be sure to specify the paper settings!

After loading paper, be sure to select the loaded paper in Media Type of the printer driver. If the type of paper is not selected, you may not be able to get the satisfactory print result.

See [Printing](#).

There are various types of paper: paper with special coating on the surface for printing photos with optimal quality and paper suitable for documents. Media Type of the printer driver has different settings for each type of paper in advance (such as using ink, ejecting ink, or distance from nozzles) so that you can print on each paper with the optimal image quality. You can print with different settings in Media Type suitable for each type of loaded paper.

### ■ Use the RESUME/CANCEL button to cancel printing!

#### ● Tip!: Never press the Power button!

If you press the **Power** button while printing is in progress, the print data sent from the computer queues in the printer and you may not be able to continue to print.

Press the **RESUME/CANCEL** button to cancel printing.



#### Note

- If you cannot cancel printing by pressing the **RESUME/CANCEL** button while printing from a computer, open the printer properties dialog box to delete the unnecessary print jobs from the printer status monitor (Windows).

### ■ How to maintain the optimal printing quality?

The key to printing with the optimal printing quality is to prevent the Print Head from drying or clogging. Always follow the following steps for optimal printing quality.

#### ● Follow the procedure below to turn the power off.

- 1 Press the **Power** button on the printer to turn it off.
- 2 Be sure that the **Power** lamp is not lit.
- 3 Unplug the power cord from the wall outlet, or turn off the extender cable connector.

If you press the **Power** button to turn off the power, the printer caps the Print Head (nozzles) automatically to prevent from drying. If you unplug the power cord from the wall outlet or turn off the extender cable connector before the **Power** lamp is turned off, the Print Head will not be capped properly and this will cause drying or clogging.

To turn off the power, be sure to follow this procedure.

#### ● Print periodically!

Just as the tip of a felt pen becomes dry and unusable if it has not been used for a long time, even if it is capped, the Print Head too, may become dried or clogged if the printer has not been used for a long time.

We recommend the printer to be used at least once a month.



#### Note

- Depending on the type of paper, ink may blur if you trace the printed area with a highlight pen or paint-stick, or bleed if water or sweat comes in contact with the printed area.

### ■ Dose the printer need to be handled with care when storing or

transporting?

- **Tip!:** Do not store or transport the printer vertically or slanted!

If the printer is stored or transported vertically or slanted, the printer may become damaged or ink may leak from the printer.

Be sure not to store or transport the printer vertically or slanted.



## ■ Lamp on the printer is flashing: What can I do?

- **Alarm lamp is flashing orange.**

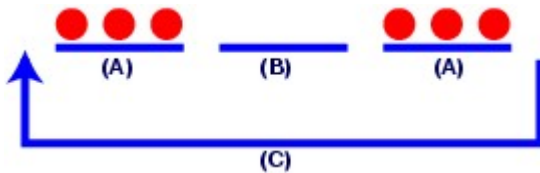

(A) Alarm lamp flashes

(B) Alarm lamp is off

(C) Alarm lamp flashes repeatedly

→Your printer has an error. Refer to the "[Troubleshooting](#)" in the on-screen manual: *Advanced Guide*, then resolve the error.

- **Power lamp flashes green once and Alarm lamp flashes orange once alternately.**

→An error that requires repair has occurred. Contact your Canon service representative.

## ■ Colors are uneven, and print results are blurred.

- **Tip!:** Print the nozzle check pattern to check if the nozzles are clogged.

If the print head nozzles are clogged, colors may become uneven or the print results may be blurred.



In this case



### Print the nozzle check pattern

Check the printed check pattern to see if the nozzles are clogged.  
See [When Printing Becomes Faint or Colors Are Incorrect](#) .



 [Page top](#)





Printing

Troubleshooting

How to Use This Manual

Printing This Manual

Maintenance

Changing the Printer Settings

Appendix

When you display this On-screen Manual in a language environment other than English, some English descriptions may be displayed.

## Printing

### Printing from a Computer

Printing with the Bundled Application Software

What Is Easy-PhotoPrint EX?

Printing Photos

Starting Easy-PhotoPrint EX

Selecting a Photo

Selecting the Paper

Printing

Creating an Album

Starting Easy-PhotoPrint EX

Selecting the Paper and Layout

Selecting a Photo

Editing

Printing

Printing Calendars

Starting Easy-PhotoPrint EX

Selecting the Paper and Layout

Selecting a Photo

Editing

Printing

Printing Stickers

Starting Easy-PhotoPrint EX

Selecting the Paper and Layout

Selecting a Photo

Editing

Printing

Printing Layout

Starting Easy-PhotoPrint EX

Selecting the Paper and Layout

Selecting a Photo

Editing

Printing

Correcting and Enhancing Photos

Using the Auto Photo Fix Function

Using the Red-Eye Correction Function

Using the Face Brightener Function

Using the Face Sharpener Function

Using the Digital Face Smoothing Function

Using the Blemish Remover Function

Adjusting Images

Correct/Enhance Images Window

#### Questions and Answers

How Can I Move (or Copy) the Saved File?

Which Side of the Displayed Image Does the Printing Start from?

How Do I Print with Even Margins?

What Is "C1" or "C4"?

#### Appendix 1: Easy-PhotoPrint EX Settings

Printing Vivid Photos

Reducing Photo Noise

Cropping Photos (Photo Print)

Printing Dates on Photos (Photo Print)

Printing Multiple Photos on One Page

Printing an Index

Printing ID Photos (ID Photo Print)

Printing Photo Information

Saving Photos

Opening Saved Files

Changing Layout

Changing Background

Adding Photos

Swapping Positions of Photos

Replacing Photos

Changing Position, Angle and Size of Photos

Cropping Photos

Framing Photos

Printing Dates on Photos

Attaching Comments to Photos

Adding Text to Photos

Saving

Setting Holidays

Setting Calendar Display

#### Printing with Other Application Software

##### Various Printing Methods

Printing with Easy Setup

Setting a Page Size and Orientation

Setting the Number of Copies and Printing Order

Setting the Stapling Margin

Borderless Printing

Fit-to-Page Printing

Scaled Printing

Page Layout Printing

Poster Printing

Booklet Printing

Duplex Printing

Stamp/Background Printing

Saving a Stamp Setting

Saving Image Data to be Used as a Background

Printing an Envelope

- Displaying the Print Results before Printing
- Setting Paper Dimensions (Custom Size)
- Changing the Print Quality and Correcting Image Data
  - Selecting a Combination of the Print Quality Level and a Halftoning Method
  - Printing a Color Document in Monochrome
  - Specifying Color Correction
  - Optimal Photo Printing of Image Data
  - Adjusting Colors with the Printer Driver
  - Printing with ICC Profiles
  - Adjusting Color Balance
  - Adjusting Brightness
  - Adjusting Intensity
  - Adjusting Contrast
  - Simulating an Illustration
  - Representing Image Data with a Single Color
  - Presenting Image Data with Vivid Colors
  - Smoothing Jagged Outlines
  - Changing Color Properties to Improve Coloration
  - Reducing Photo Noise
- Overview of the Printer Driver
  - Canon IJ Printer Driver
  - How to Open the Printer Driver Setup Window
  - Maintenance Tab
  - Canon IJ Status Monitor
  - The Canon IJ Preview

## Troubleshooting

### Troubleshooting

- If an Error Occurs
  - The Printer Can Not Be Powered On
  - Alarm Lamp Flashes Orange
  - Power Lamp Flashes Green and Alarm Lamp Flashes Orange Alternately
  - Cannot Install the Printer Driver
  - Cannot Connect to Computer Properly
    - The Printer Is Not Recognized Properly
- Print Results Not Satisfactory
  - Cannot Print to End of Job
  - No Printing Results/Printing Is Blurred/Colors Are Wrong/White Streaks
  - Colors Are Unclear
  - Lines Are Misaligned
  - Printed Paper Curls or Has Ink Blots
  - Paper Is Smudged/Printed Surface Is Scratched
  - Back of the Paper Is Smudged
  - Colors Are Uneven or Streaked
- Printing Does Not Start
- Printing Stops Before It Is Completed
- Printer Moves But Ink Is Not Ejected

Printing Speed Not as Fast as Expected

FINE Cartridge Holder Does Not Move to the Position for Replacing

Paper Does Not Feed Properly

Paper Jams

Message Appears on the Computer Screen

Service Error 5100 Is Displayed

Writing Error/Output Error/Communication Error

Error Number: 300 Is Displayed

Error Number: 1700 Is Displayed

Ink Info Number: 1688 Is Displayed

Ink Info Number: 1686 Is Displayed

Other Error Messages

For Windows Users

Printer Status Monitor Is Not Displayed

The Inkjet Printer/Scanner Extended Survey Program screen is displayed

FAQs

If You Cannot Resolve the Problem

Instructions for Use (Printer Driver)

## **Using Easy-PhotoPrint EX**

## **About Solution Menu**

## Advanced Guide

Advanced Guide > How to Use This Manual

---

### How to Use This Manual

- ➔ [Operating the Contents Screen](#)
- ➔ [Operating the Explanation Screen](#)
- ➔ [Printing This Manual](#)
- ➔ [Using Keywords to Find a Topic](#)
- ➔ [Registering Topics to My Manual](#)
- ➔ [Symbols Used in this Document](#)
- ➔ [Trademarks](#)

[Page top](#) ↕

## Advanced Guide

Advanced Guide > How to Use This Manual > Operating the Contents Screen

# Operating the Contents Screen

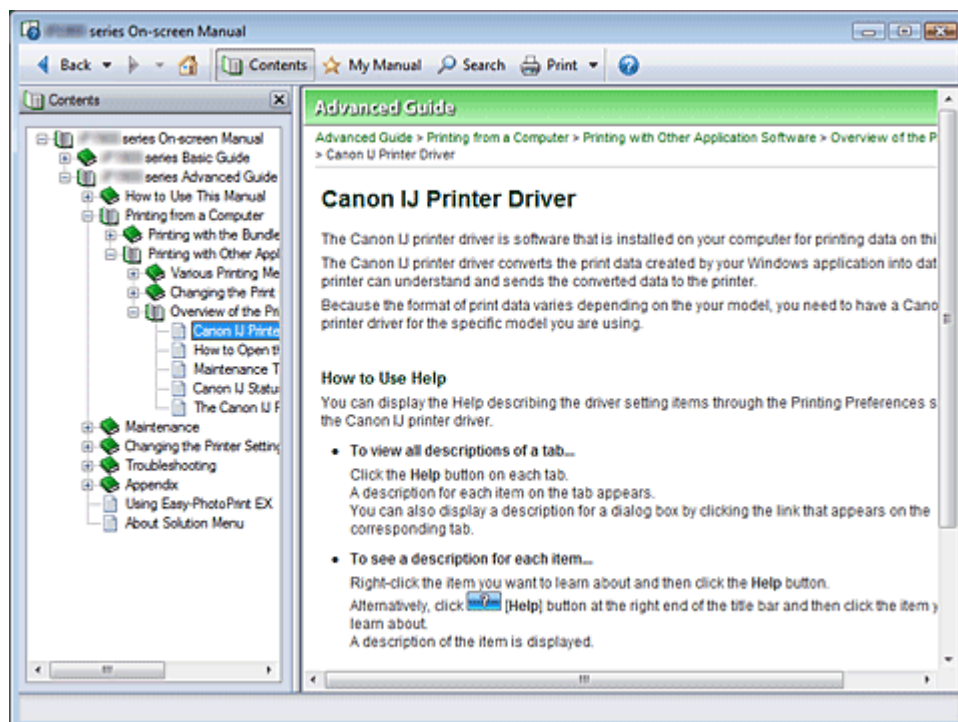

When you click a title displayed in the Contents screen found to the left of the On-screen Manual, the pages of that title are displayed in the Description window.

When you click  found to the left of , the titles found in the lower hierarchies are displayed.

### Note

- Click  to close or display the Contents screen.

## Advanced Guide

Advanced Guide > How to Use This Manual > Operating the Explanation Screen

### Operating the Explanation Screen

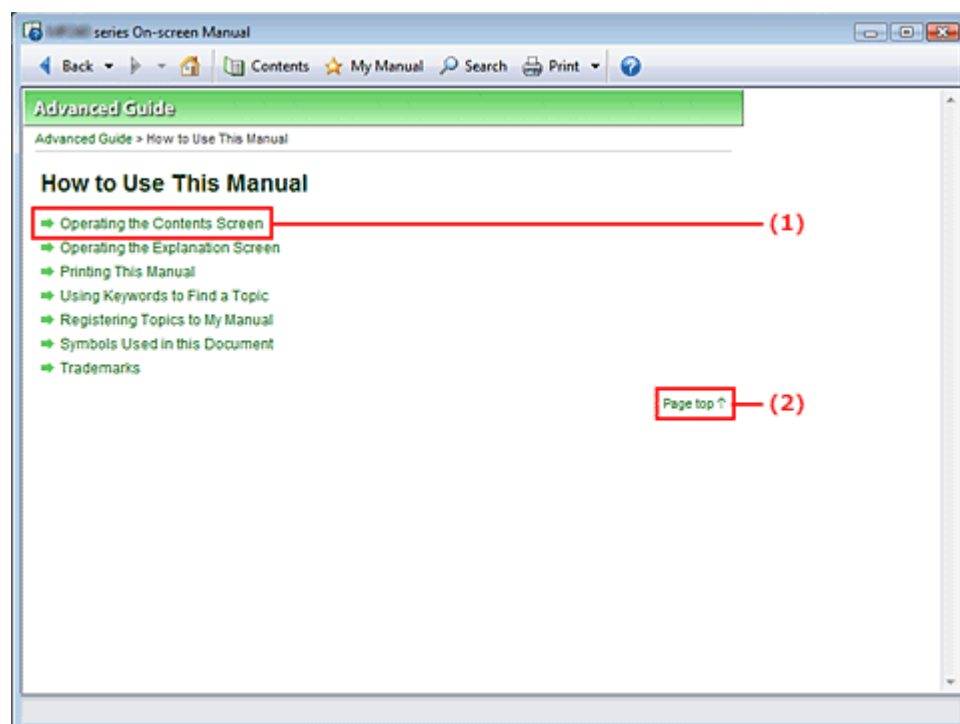

(1) Click the green characters to jump to the corresponding page.

(2) The cursor jumps to the top of this page.

Page top ↑

## Advanced Guide



Advanced Guide > How to Use This Manual > Printing This Manual

## Printing This Manual



Click  to display the Print window to the left of the On-screen Manual.

### Note

- Click  to close or display the Print window.
- Click , and then click Option Settings to display the Option Settings dialog box. You can then set up the printing operation.

The following four methods of printing are available:

- [Current Document](#)
- [Selected Documents](#)
- [My Manual](#)
- [All Documents](#)

### Current Document

You can print the currently displayed topic.

#### 1. From Select Target, select Current Document

The title of the currently displayed topic is displayed in the Documents to Be Printed list.

### Note

- By selecting Print linked documents, you can also print documents that are linked to the current document. The linked documents are added to the Documents to Be Printed list.
- Click Print Preview to display and check what the print results will look like before you actually print the document.

#### 2. Click Start Printing

The Print Page Count Confirmation dialog box is displayed.

#### 3. Execute print



Confirm the number of pages to be printed, and then click Yes.  
The topics that are currently displayed are printed.

## Selected Documents

You can select and print the topics that you want printed.

### 1. From Select Target, select Selected Documents

The titles of all topics are displayed in the Documents to Be Printed list.

### 2. Select the topics to be printed

From the Documents to Be Printed list, select the title check boxes of the topics to be printed.



#### Note

- When you select the Automatically select documents in lower hierarchies check box, the check boxes of all titles found in the lower hierarchies are selected.
- Click Select All to select the check boxes of all titles.  
Click Clear All to clear the check boxes of all titles.
- Click Print Preview to display and check what the print results will look like before you actually print the document.

### 3. Click Start Printing

The Print Page Count Confirmation dialog box is displayed.

### 4. Execute print

Confirm the number of pages to be printed, and then click Yes.  
All topics with selected check boxes are printed.

## My Manual

You can select and print topics registered in My Manual.

For details about My Manual, see "[Registering Topics to My Manual](#)."

### 1. From Select Target, select My Manual

The titles of the topics that have been registered to My Manual are displayed in the Documents to Be Printed list.

### 2. Select the topics to be printed

From the Documents to Be Printed list, select the title check boxes of the topics to be printed.



#### Note

- Click Select All to select the check boxes of all titles.  
Click Clear All to clear the check boxes of all titles.
- Click Print Preview to display and check what the print results will look like before you actually print the document.

### 3. Click Start Printing

The Print Page Count Confirmation dialog box is displayed.

### 4. Execute print

Confirm the number of pages to be printed, and then click Yes.  
All topics with selected check boxes are printed.

## All Documents

You can print all topics of the On-screen Manual.

### 1. From Select Target, select All Documents

The titles of all topics are displayed in the Documents to Be Printed list, and the check boxes are automatically selected.

**Note**

- If you clear the check box of a topic, that topic is not printed.
- Click Select All to select the check boxes of all titles.  
Click Clear All to clear the check boxes of all titles.
- Click Print Preview to display and check what the print results will look like before you actually print the document.

**2. Click Start Printing**

The Print Page Count Confirmation dialog box is displayed.

**3. Execute print**

Confirm the number of pages to be printed, and then click Yes.

All topics are printed.

**Important**

- A large amount of paper is necessary to print all topics. Before printing, be sure to check the number of print pages displayed in the Print Page Count Confirmation dialog box.

[Page top](#) ↕

## Advanced Guide

Advanced Guide > How to Use This Manual > Using Keywords to Find a Topic

### Using Keywords to Find a Topic

You can enter a keyword to search for a target page.

All installed On-screen Manuals (user's guides) are searched.



#### 1. Click

A search window is displayed to the left of the On-screen Manual.

#### Note

- Click  to close or display the Search window.

#### 2. Enter a keyword

In Keyword, enter a keyword for the item to be checked.

If you want to enter multiple keywords, insert a space between the keywords.

#### Note

- You can enter up to 10 keywords or up to 255 characters.
- Uppercase and lowercase are not discriminated.
- The program can also search for keywords that contain spaces.

#### 3. Click Start Searching

The search is started, and the titles of topics containing the keyword are displayed in the search results list.

When you execute a search by entering multiple keywords, the search results are displayed as shown below.

##### **[Documents Containing Perfect Match]**

Topics containing the entire search character string (including spaces) exactly as entered (perfect match)

##### **[Documents Containing All Keywords]**

Topics containing all keywords that were entered

##### **[Documents Containing Any Keyword]**

Topics containing at least one of the keywords that were entered

#### 4. Display the topic that you want to read

From the search results list, double-click (or select and press Enter) the title of the topic you want to read.

When the pages of that title are displayed, the keywords found on those pages are highlighted.

[Page top](#) ↕

## Advanced Guide

Advanced Guide > How to Use This Manual > Registering Topics to My Manual

# Registering Topics to My Manual

Register frequently read pages as My Manual topics so that you can refer to those pages easily at any time.



### 1. Display the topic

Display the topic to be added to My Manual.

### 2. Click My Manual

The My Manual window is displayed to the left of the On-screen Manual.

#### Note

- Click  to close or display the My Manual window.

### 3. Register the topic to My Manual

Click Add.

The currently displayed topic is added to List of My Manual.

#### Note

- Alternatively, from the Recently Displayed Documents list, double-click (or select and press Enter) the topic to be added to My Manual to display that topic, and then click Add.

### 4. Display My Manual

When you double-click (or select and press Enter) a topic displayed in List of My Manual, that topic is displayed in the Description window.

#### Note

- To delete a topic from List of My Manual, select that topic from the list, and then click Delete (or press Delete).

## Advanced Guide

[Advanced Guide](#) > [How to Use This Manual](#) > [Symbols Used in this Document](#)

---

### Symbols Used in this Document

#### **Warning**

Instructions that, if ignored, could result in death or serious personal injury caused by incorrect operation of the equipment. These must be observed for safe operation.

#### **Caution**

Instructions that, if ignored, could result in personal injury or material damage caused by incorrect operation of the equipment. These must be observed for safe operation.

#### **Important**

Instructions that must be observed for safe operation.

#### **Note**

Instructions as notes for operation or additional explanations.

#### **Windows**

Indicates operations in Windows.

#### **Macintosh**

Indicates operations in Macintosh.

[Page top](#) 

## Advanced Guide

[Advanced Guide](#) > [How to Use This Manual](#) > [Trademarks](#)

---

### Trademarks

- Microsoft is a registered trademark of Microsoft Corporation.
- Windows is a trademark or registered trademark of Microsoft Corporation in the U.S. and/or other countries.
- Windows Vista is a trademark or registered trademark of Microsoft Corporation in the U.S. and/or other countries.
- Macintosh and Mac are trademarks of Apple Inc., registered in the U.S. and other countries.
- Adobe, Adobe Photoshop, Adobe RGB and Adobe RGB (1998) are either registered trademarks or trademarks of Adobe Systems Incorporated in the United States and or other countries.

[Page top](#) ↕

## Advanced Guide

Advanced Guide > Printing from a Computer

---

### Printing from a Computer

- ➔ [Printing with the Bundled Application Software](#)
- ➔ [Printing with Other Application Software](#)

[Page top](#) ↑



## Advanced Guide

Advanced Guide > Printing from a Computer > Printing with the Bundled Application Software

---

### Printing with the Bundled Application Software

- ➔ [What Is Easy-PhotoPrint EX?](#)
- ➔ [Printing Photos](#)
- ➔ [Creating an Album](#)
- ➔ [Printing Calendars](#)
- ➔ [Printing Stickers](#)
- ➔ [Printing Layout](#)
- ➔ [Correcting and Enhancing Photos](#)
- ➔ [Questions and Answers](#)
- ➔ [Appendix 1: Easy-PhotoPrint EX Settings](#)

[Page top](#) ↕

## Advanced Guide

Advanced Guide > Printing from a Computer > Printing with the Bundled Application Software > What Is Easy-PhotoPrint EX?

### What Is Easy-PhotoPrint EX?

Easy-PhotoPrint EX allows you to create albums, calendars and stickers easily using photos taken with digital cameras.

You can also print borderless photos easily.

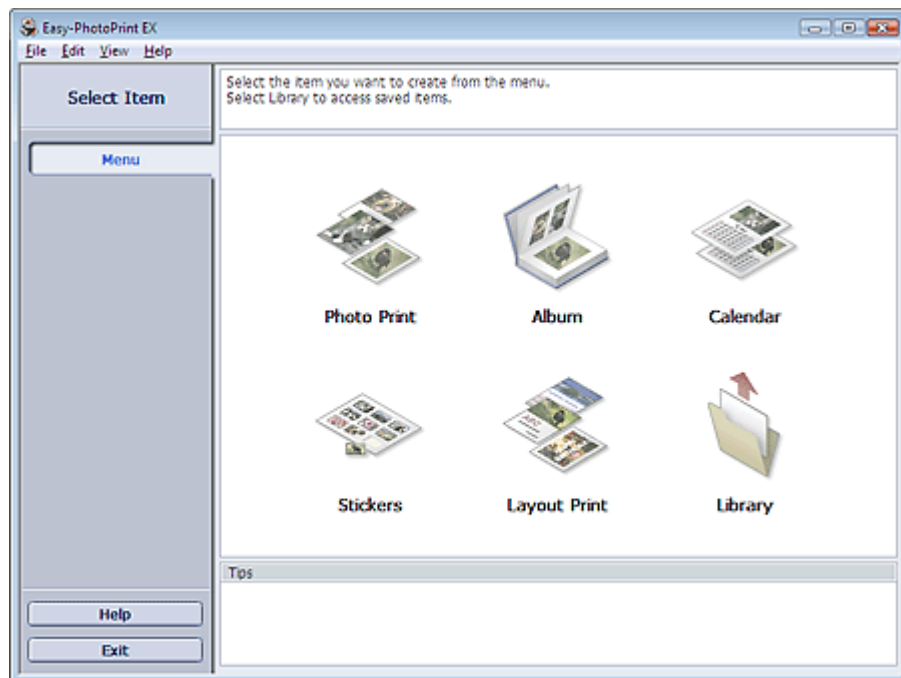

#### Important

- Easy-PhotoPrint EX does not support Windows 95, Windows 98, Windows Me, or Windows NT4.
- Easy-PhotoPrint EX can only be used with Canon inkjet printers. It does not support some printers, including Canon compact printers (SELPHY CP series).
- If a printer that supports Easy-PhotoPrint EX is not installed, you cannot print items you create.
- If Easy-PhotoPrint EX is installed on a computer that already has Easy-LayoutPrint installed, Easy-LayoutPrint will be replaced by Easy-PhotoPrint EX.

#### Note

- Printing on paper larger than A4 is available with supported printers only. See your printer manual for details.
- See Help of Easy-PhotoPrint EX for descriptions of Easy-PhotoPrint EX screens. Click Help in a screen or dialog box, or select Easy-PhotoPrint EX Help from the Help menu. Help appears.

#### About Exif Print

Easy-PhotoPrint EX supports "Exif Print." Exif Print is a standard for enhancing the communication between digital cameras and printers.

By connecting to an Exif Print-compliant digital camera, the image data at the time of shooting is used and optimized, yielding extremely high quality prints.

#### Starting Easy-PhotoPrint EX from Other Applications

Easy-PhotoPrint EX can be started from other applications.

See the application's manual for details on the procedure for starting.

The Album function is available with the following applications:

- MP Navigator EX Ver.1.00 or later
- ZoomBrowser EX Ver.5.8 or later

The Photo Print function is available with the following applications:

- MP Navigator EX Ver.1.00 or later
- ZoomBrowser EX Ver.6.0 or later
- Digital Photo Professional Ver.3.2 or later

#### Note

- Easy-PhotoPrint EX is subject to the following restrictions when started from Digital Photo Professional:
  - Menu does not appear in the step button area on the left side of the screen.
  - Images cannot be corrected/enhanced.
  - Image display order cannot be changed.
  - Edited images cannot be saved.
  - Options other than Enable ICC Profile cannot be selected for Color correction for printing on the Advanced tab of the Preferences dialog box. Therefore, you cannot use the Vivid Photo and Photo Noise Reduction functions.

### Supported Image File Formats (Extensions)

- BMP (.bmp)
- JPEG (.jpg, .jpeg)
- TIFF (.tif, .tiff)
- PICT (.pict, .pct)
- Easy-PhotoPrint image files (.epp)

#### Important

- When selecting an image, if there is a TIFF file in the selected folder, the image may not be displayed correctly or Easy-PhotoPrint EX may shut down depending on the TIFF format. In such cases, move the TIFF file to another folder or recreate the file in a different file format, and then select the folder again.

- The thumbnails of files in unsupported formats are displayed as  (Question Mark).

#### Note

- When Easy-PhotoPrint EX is started from Digital Photo Professional, all image files supported by Digital Photo Professional will be displayed.

### File Formats (Extensions) Supported by Easy-PhotoPrint EX

- Easy-PhotoPrint EX Photo Print file (.el6)
- Easy-PhotoPrint EX Album file (.el1)
- Easy-PhotoPrint EX Stickers file (.el2)
- Easy-PhotoPrint EX Calendar file (.el4)
- Easy-PhotoPrint EX Layout file (.el5)

## Advanced Guide

Advanced Guide > Printing from a Computer > Printing with the Bundled Application Software > Printing Photos

### Printing Photos

Easy-PhotoPrint EX allows you to print your favorite photos in a variety of layouts.

You can also create borderless photos easily.

Corrections suitable for photos will be applied automatically when printing.



#### Steps

1. Starting Easy-PhotoPrint EX
2. Selecting a Photo
3. Selecting the Paper
4. Printing

#### Try This

- ➔ Correcting and Enhancing Photos
- ➔ Printing Vivid Photos
- ➔ Reducing Photo Noise
- ➔ Cropping Photos (Photo Print)
- ➔ Printing Dates on Photos (Photo Print)
- ➔ Printing Multiple Photos on One Page
- ➔ Printing an Index
- ➔ Printing ID Photos (ID Photo Print)
- ➔ Printing Photo Information
- ➔ Saving Photos
- ➔ Opening Saved Files

#### Questions and Answers

- ➔ How Can I Move (or Copy) the Saved File?
- ➔ Which Side of the Displayed Image Does the Printing Start from?
- ➔ How Do I Print with Even Margins?

## Advanced Guide

Advanced Guide > Printing from a Computer > Printing with the Bundled Application Software > Printing Photos > Starting Easy-PhotoPrint EX

### Starting Easy-PhotoPrint EX

1. From the Start menu, select (All) Programs > Canon Utilities > Easy-PhotoPrint EX > Easy-PhotoPrint EX.

Easy-PhotoPrint EX starts and Menu appears.

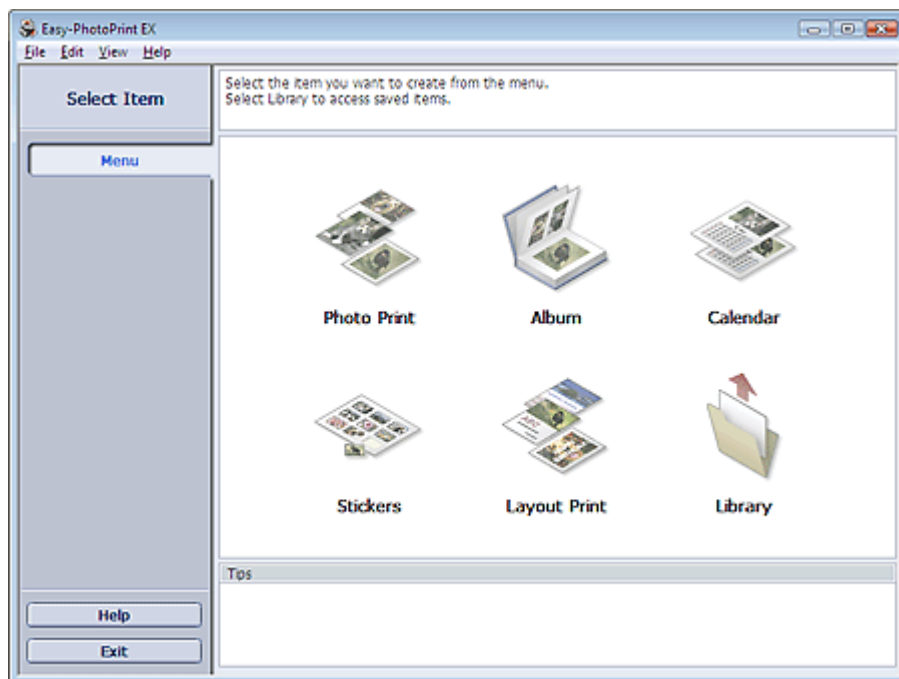

## Advanced Guide

Advanced Guide > Printing from a Computer > Printing with the Bundled Application Software > Printing Photos > Selecting a Photo

## Selecting a Photo

### 1. Click Photo Print from Menu.

The Select Images screen appears.

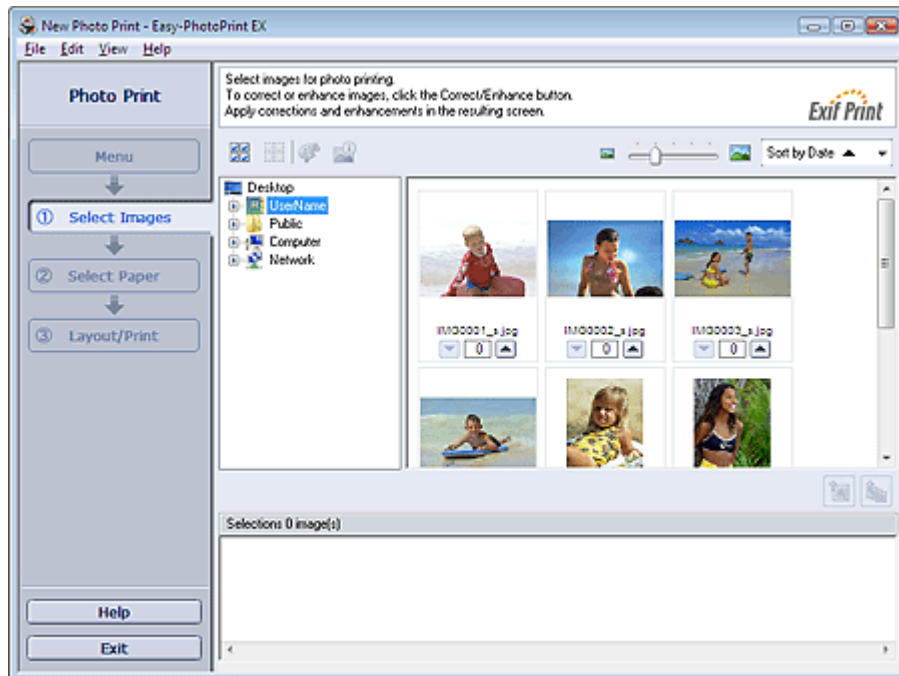

### Important

- The reduced images (thumbnails) displayed in the screen may appear as follows:
  - A black line appears along an edge of the image.
  - An edge of the image appears cropped.
 However, such images will be displayed normally when enlarged or previewed, and print results will not be affected.

### 2. Select the folder that contains the image you want to print from the folder tree area.

The images in the folder will be displayed as thumbnails (miniatures).

### Note

- If Easy-PhotoPrint EX is started from another application (MP Navigator EX, ZoomBrowser EX or Digital Photo Professional), the folder tree area will not be displayed. The images opened in the application will be displayed as thumbnails.



### 3. Click the image you want to print.

The number of copies appears as "1" below the clicked image, while the selected image itself will appear in the selected image area.

### Note

- To delete an image in the selected image area, select the image you want to delete and click  (Delete Imported Image).

To delete all images from the selected image area, click  (Delete All Imported Images).

- To print two or more copies of an image, click  (Up arrow) until the number of copies you want is reached. To reduce the number of copies shown in the box, click  (Down arrow).
- You can change the order of photos using the list located at the top right corner of the screen. You can select the printing order from Sort by Date and Sort by Name.

 **Note**

- 
- You can correct or enhance the selected image before printing.
    - ➔ [Correcting and Enhancing Photos](#)
  - See Help for details on the Select Images screen.
- 

[Page top](#)↑

## Advanced Guide

Advanced Guide > Printing from a Computer > Printing with the Bundled Application Software > Printing Photos > Selecting the Paper

## Selecting the Paper

### 1. Click Select Paper.

The Select Paper screen appears.

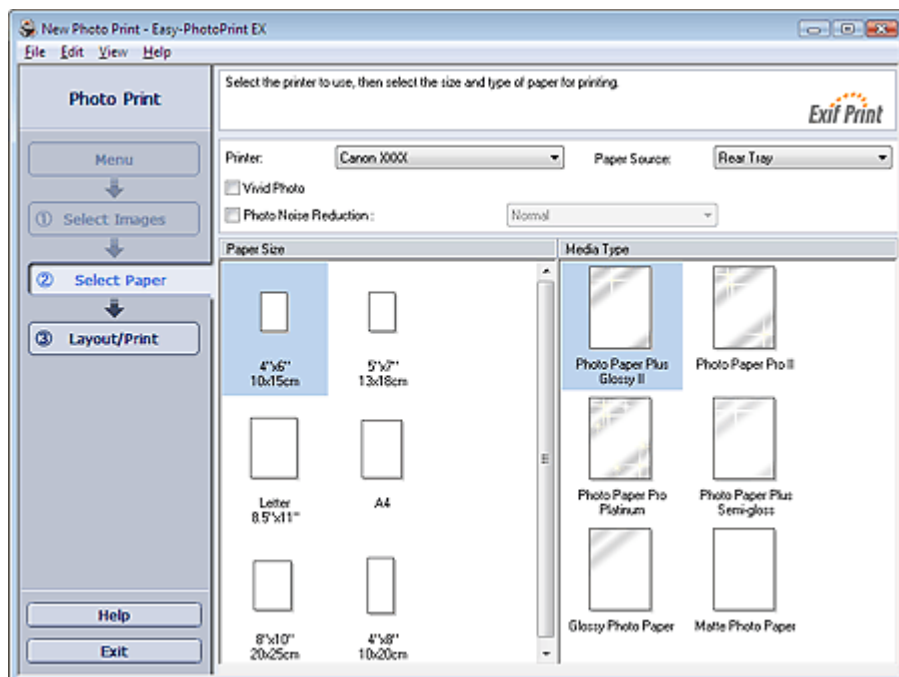

### 2. Set the following items according to the printer and paper to be used:

Printer

Paper Source

Paper Size

Media Type



#### Note

- The paper sizes and media types may vary depending on the printer. See Help for details.
- The paper sources may vary depending on the printer and the media type.

#### Important

- When Fine Art Photo Rag is selected for Media Type, a 1.38 inch (35 mm) margin is automatically left at the top and bottom of the paper. It is recommended that you check the print range with the image shown in Preview before printing.

#### Note

- You can print photos with more vivid colors or you can reduce the photo noise.
  - ➔ [Printing Vivid Photos](#)
  - ➔ [Reducing Photo Noise](#)
- See Help for details on the Select Paper screen.





## Advanced Guide

Advanced Guide > Printing from a Computer > Printing with the Bundled Application Software > Printing Photos > Printing

## Printing

### 1. Click Layout/Print.

The Layout/Print screen appears.

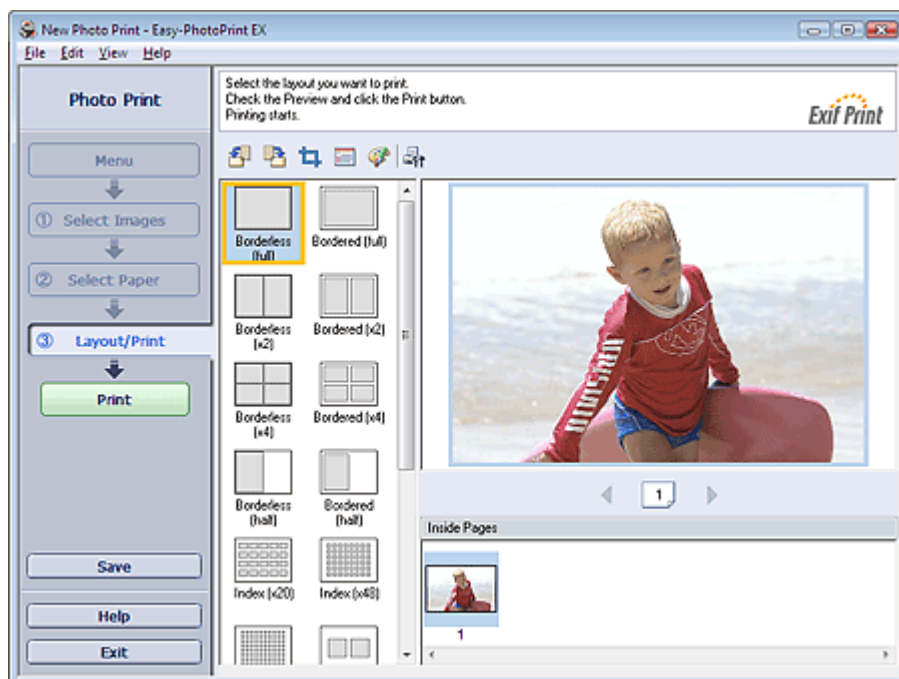

### Important

- The reduced images (thumbnails) displayed in the screen may appear as follows:
  - A black line appears along an edge of the image.
  - An edge of the image appears cropped.
 However, such images will be displayed normally when enlarged or previewed, and print results will not be affected.

### 2. Select a layout you want to use.

Click a borderless layout to print borderless photos.

### Note

- The layouts that can be selected may vary depending on the printer, paper size, and media type.

### 3. Click Print.

### Important

- When you print on large size paper such as A3/A3+, some computers cannot print properly if you print more than one page or copy at a time. It is recommended that you print page by page when you print on such paper.
- While printing on paper larger than A4 or printing high-resolution images, data may be printed only to the middle if many images are printed at one time. In such cases, select the Spool print job page by page checkbox in the Preferences dialog box, and then print again.

To display the Preferences dialog box, click  (Settings) or select Preferences... from the File menu.

- When Fine Art Photo Rag is selected for Media Type in the Select Paper screen, a 1.38 inch (35 mm) margin is automatically left at the top and bottom of the paper. It is recommended that you check the print range with the image shown in Preview before printing.

### Note

- The photo print settings will be discarded if you exit Easy-PhotoPrint EX without saving the settings.

It is recommended that you save the printed image if you want to print it again.

➔ [Saving Photos](#)

- When you print on a bordered layout, the margins on the left and right or the top and bottom may become wider than the other.

➔ [How Do I Print with Even Margins?](#)

- You can crop images or print dates on photos.

➔ [Cropping Photos \(Photo Print\)](#)

➔ [Printing Dates on Photos \(Photo Print\)](#)

- You can correct or enhance the selected image before printing.

➔ [Correcting and Enhancing Photos](#)

- You can specify advanced Photo Print settings (number of copies, print quality, etc.) in the Preferences dialog box.

To display the Preferences dialog box, click  (Settings) or select Preferences... from the File menu.

- See Help for details on the Layout/Print screen.
- 



[Page top](#)↑

## Advanced Guide

Advanced Guide > Printing from a Computer > Printing with the Bundled Application Software > Creating an Album

# Creating an Album

Easy-PhotoPrint EX allows you to create your own personalized photo album.

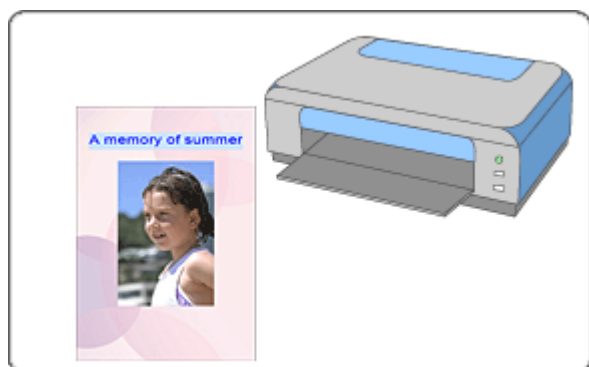

## Steps

1. Starting Easy-PhotoPrint EX
2. Selecting the Paper and Layout
3. Selecting a Photo
4. Editing
5. Printing

## Try This

- ➔ Correcting and Enhancing Photos
- ➔ Changing Layout
- ➔ Changing Background
- ➔ Adding Photos
- ➔ Swapping Positions of Photos
- ➔ Replacing Photos
- ➔ Changing Position, Angle and Size of Photos
- ➔ Cropping Photos
- ➔ Framing Photos
- ➔ Printing Dates on Photos
- ➔ Attaching Comments to Photos
- ➔ Adding Text to Photos
- ➔ Saving
- ➔ Opening Saved Files

## Questions and Answers

- ➔ How Can I Move (or Copy) the Saved File?
- ➔ What Is "C1" or "C4"?

## Advanced Guide

Advanced Guide > Printing from a Computer > Printing with the Bundled Application Software > Creating an Album > Starting Easy-PhotoPrint EX

## Starting Easy-PhotoPrint EX

1. From the Start menu, select (All) Programs > Canon Utilities > Easy-PhotoPrint EX > Easy-PhotoPrint EX.

Easy-PhotoPrint EX starts and Menu appears.

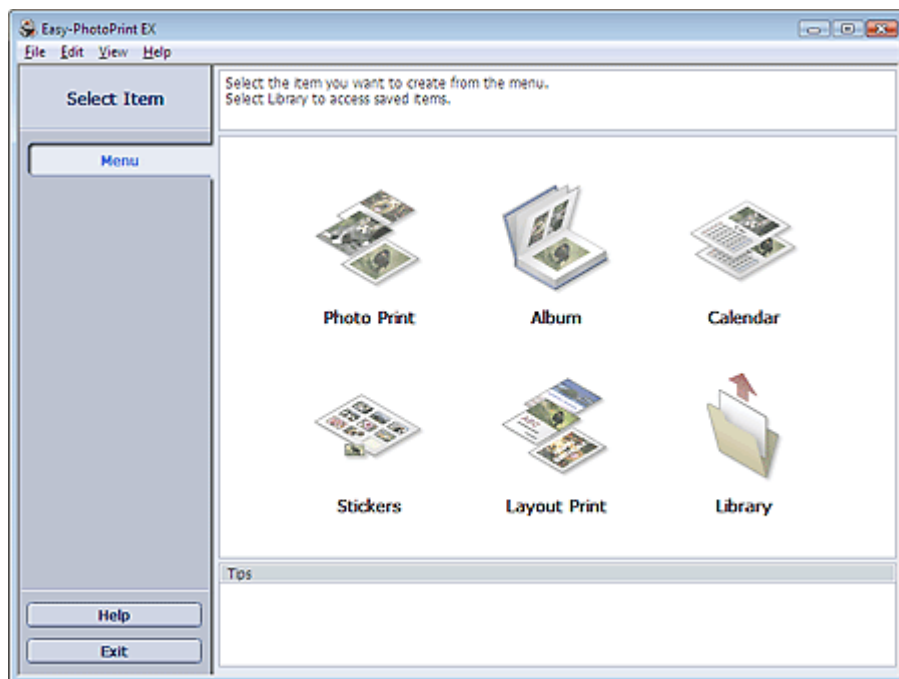

[Page top](#)↑

## Advanced Guide

Advanced Guide > Printing from a Computer > Printing with the Bundled Application Software > Creating an Album > Selecting the Paper and Layout

### Selecting the Paper and Layout

#### 1. Click Album from Menu.

The Page Setup screen appears.

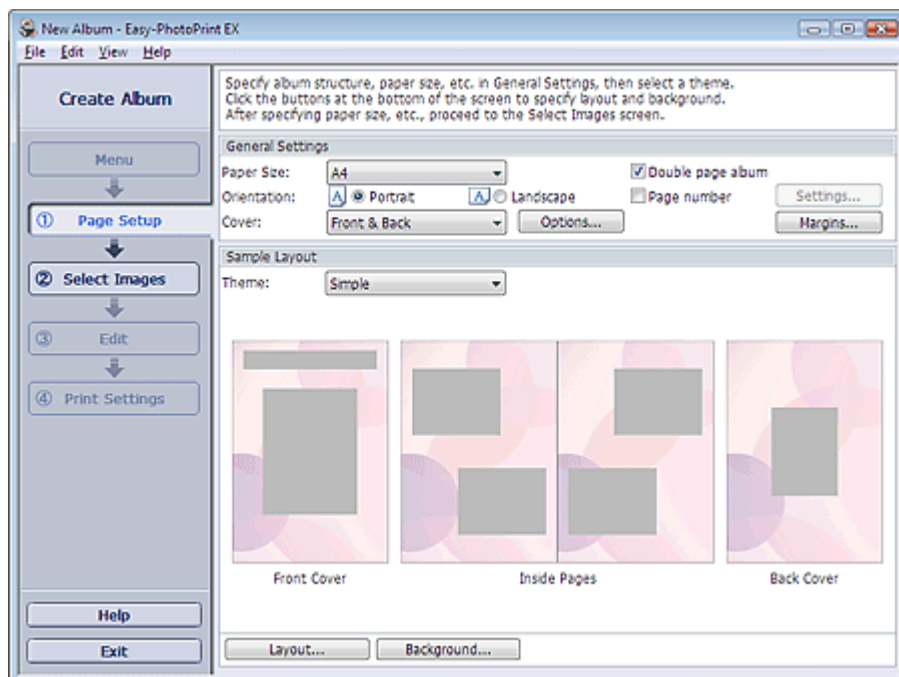

#### 2. Set the following items in the General Settings section:

Paper Size

Orientation

Cover

Double page album

Page number



#### Note

- See Help on the paper size that can be selected.
- You can select whether to display images on the inside of the front and back covers in the Cover Options dialog box. To display the Cover Options dialog box, select Front or Front & Back for Cover and click Options....
- Select the Double page album checkbox to enable the spread page layout (consisting of two-page master). In a double-page album, you can arrange an image across the left and right pages.
- You can customize the page numbers (position, font size, etc.) in the Page Number Settings dialog box. To display the Page Number Settings dialog box, select the Page number checkbox and click Settings....
- You can customize the margins of the front cover, inside pages and back cover in the Margin Settings dialog box. To display the Margin Settings dialog box, click Margins....

#### 3. Select the theme you want to use from Theme in Sample Layout.

#### 4. If you want to change the layout, click Layout....

The Change Layout dialog box appears.

In the Change Layout dialog box, you can change the layout or select whether to print the date (on which the picture was taken) on the photo.



#### Note

- The album layouts that can be selected may vary depending on the Paper Size, Orientation, Double page album, or the type of page selected (front cover, inside pages or back cover).
  - You can customize the date (position, size and color) in the Date Settings dialog box. To display the Date Settings dialog box, select the Print date checkbox in the Change Layout dialog box and click Date Settings....
- 

## 5. If you want to change the background, click Background....

The Change Background dialog box appears.

In the Change Background dialog box, you can paint the background in a single color or paste an image file to it.

### Note

---

- See Help for details on the Page Setup screen.
- 



[Page top](#)

## Advanced Guide

Advanced Guide > Printing from a Computer > Printing with the Bundled Application Software > Creating an Album > Selecting a Photo

## Selecting a Photo

### 1. Click Select Images.

The Select Images screen appears.

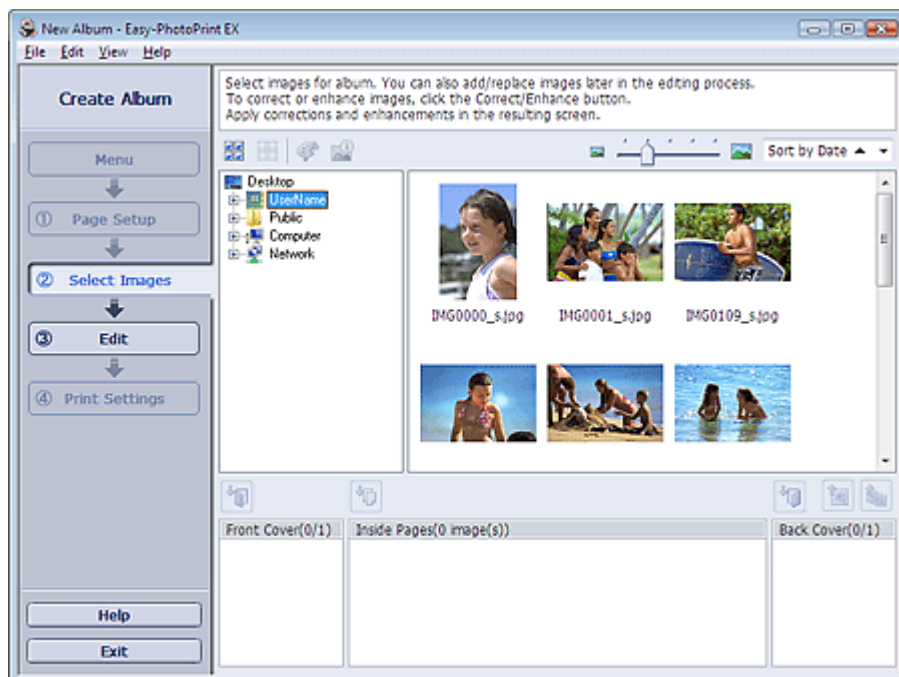

### 2. Select the folder that contains the image you want to print from the folder tree area.

The images in the folder will be displayed as thumbnails (miniatures).



#### Note

- If Easy-PhotoPrint EX is started from another application (MP Navigator EX or ZoomBrowser EX), the folder tree area will not be displayed. The images opened in MP Navigator EX or ZoomBrowser EX will be displayed as thumbnails.

### 3. Select the image(s) you want to print, and click one of the buttons below.

To print on the front cover, click  (Import to Front Cover).

To print on the inside pages, click  (Import to Inside Pages).

To print on the back cover, click  (Import to Back Cover).

The selected images are displayed in the selected image area.

You can also select the image(s) you want to print by dragging them into the selected image area.



#### Note

- To delete an image in the selected image area, select the image you want to delete and click



(Delete Imported Image).

To delete all images from the selected image area, click  (Delete All Imported Images).



#### Note

- See Help for details on the Select Images screen.



[Page top](#)↑



## Advanced Guide

Advanced Guide > Printing from a Computer > Printing with the Bundled Application Software > Creating an Album > Editing

## Editing

### 1. Click Edit.

The Edit screen appears.

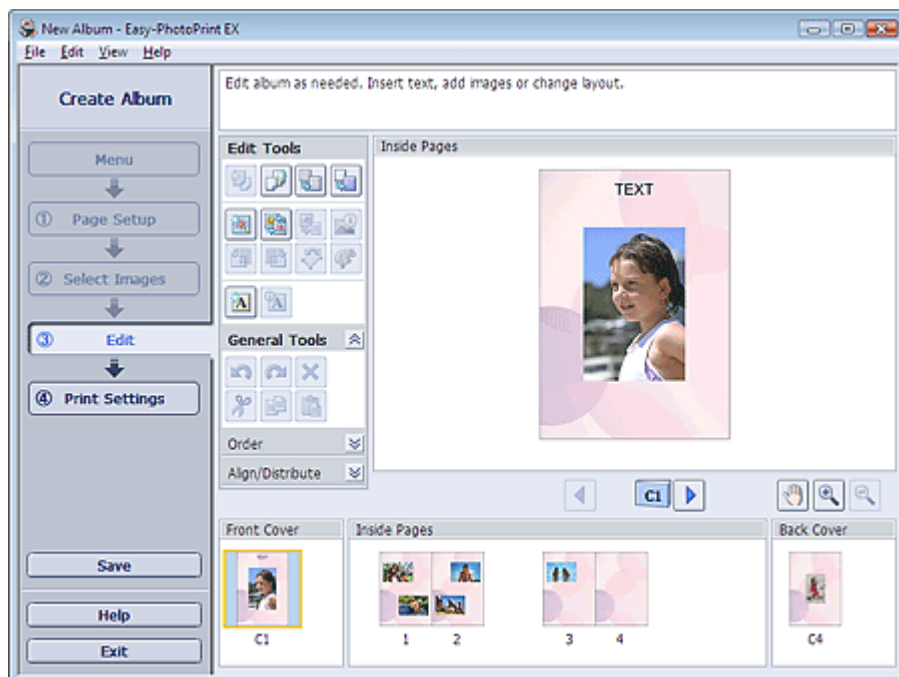

### 2. Edit your album if necessary.

- ➔ Changing Layout
- ➔ Changing Background
- ➔ Adding Photos
- ➔ Swapping Positions of Photos
- ➔ Replacing Photos
- ➔ Changing Position, Angle and Size of Photos
- ➔ Cropping Photos
- ➔ Framing Photos
- ➔ Printing Dates on Photos
- ➔ Attaching Comments to Photos
- ➔ Adding Text to Photos

#### Note

- The edit information will be discarded if you exit Easy-PhotoPrint EX without saving the edited album. It is recommended that you save the item if you want to edit it again.

The page numbers on the front and back covers of the album are displayed as follows:

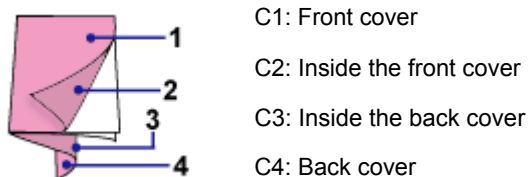

- ➔ Saving
- See Help for details on the Edit screen.





## Advanced Guide

Advanced Guide > Printing from a Computer > Printing with the Bundled Application Software > Creating an Album > Printing

## Printing

### 1. Click Print Settings.

The Print Settings screen appears.

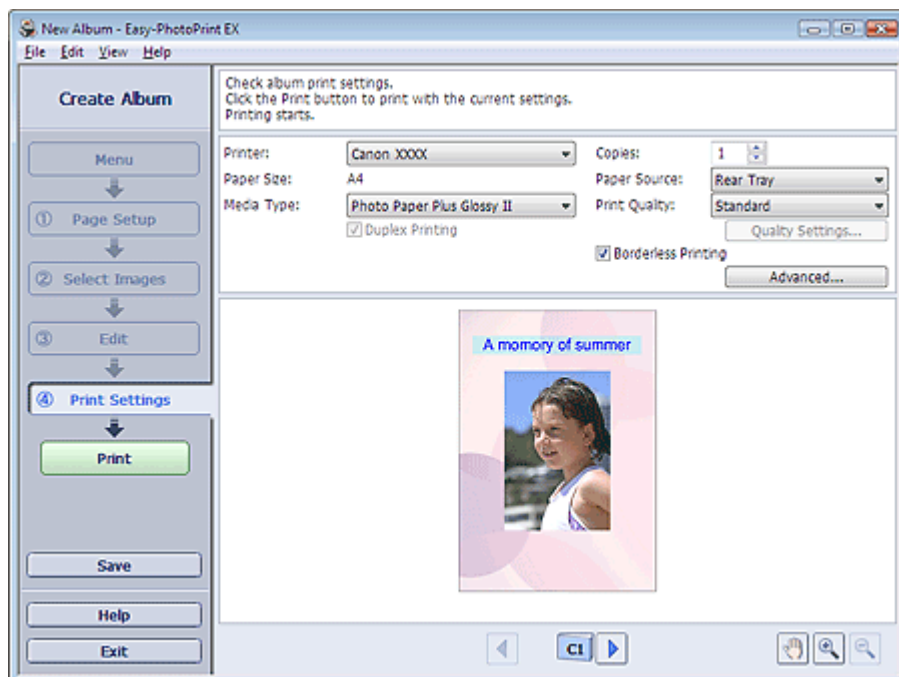

### 2. Set the following items according to the printer and paper to be used:

Printer

Media Type

Copies

Paper Source

Print Quality

Borderless Printing



#### Note

- The media types may vary depending on the printer and the paper size.
- Duplex Printing appears if the selected printer and media type support duplex printing. Select this checkbox to print on both sides of the paper.
- Automatic appears if you select the Duplex Printing checkbox after selecting a printer that supports automatic duplex printing and media type that supports duplex printing. Select this checkbox to print on both sides of the paper automatically.
- The paper sources may vary depending on the printer and the media type.
- You can set a custom print quality level in the Print Quality Settings dialog box. To display the Print Quality Settings dialog box, select Custom for Print Quality and click Quality Settings....
- Select the Borderless Printing checkbox to print borderless photos.
- You can specify the print range and the amount of extension for borderless printing in the Print Settings dialog box. To display the Print Settings dialog box, click Advanced....

### 3. Click Print.



#### Note

- See Help for details on the Print Settings screen.





## Advanced Guide

Advanced Guide > Printing from a Computer > Printing with the Bundled Application Software > Printing Calendars

# Printing Calendars

Easy-PhotoPrint EX allows you to create your own calendar using your favorite photos.

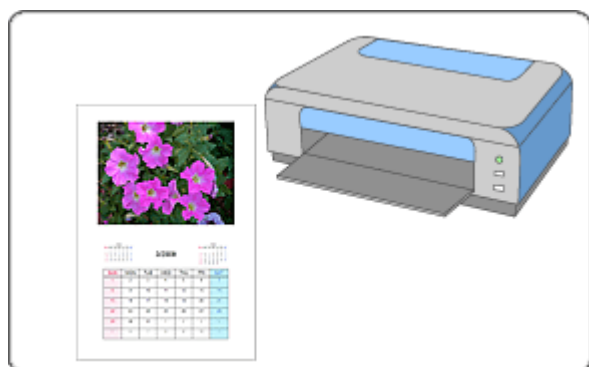

## Steps

1. Starting Easy-PhotoPrint EX
2. Selecting the Paper and Layout
3. Selecting a Photo
4. Editing
5. Printing

## Try This

- ➔ Correcting and Enhancing Photos
- ➔ Changing Layout
- ➔ Changing Background
- ➔ Adding Photos
- ➔ Swapping Positions of Photos
- ➔ Replacing Photos
- ➔ Changing Position, Angle and Size of Photos
- ➔ Cropping Photos
- ➔ Framing Photos
- ➔ Printing Dates on Photos
- ➔ Adding Text to Photos
- ➔ Setting Calendar Display
- ➔ Setting Holidays
- ➔ Saving
- ➔ Opening Saved Files

## Questions and Answers

- ➔ How Can I Move (or Copy) the Saved File?

## Advanced Guide

Advanced Guide > Printing from a Computer > Printing with the Bundled Application Software > Printing Calendars > Starting Easy-PhotoPrint EX

## Starting Easy-PhotoPrint EX

1. From the Start menu, select (All) Programs > Canon Utilities > Easy-PhotoPrint EX > Easy-PhotoPrint EX.

Easy-PhotoPrint EX starts and Menu appears.

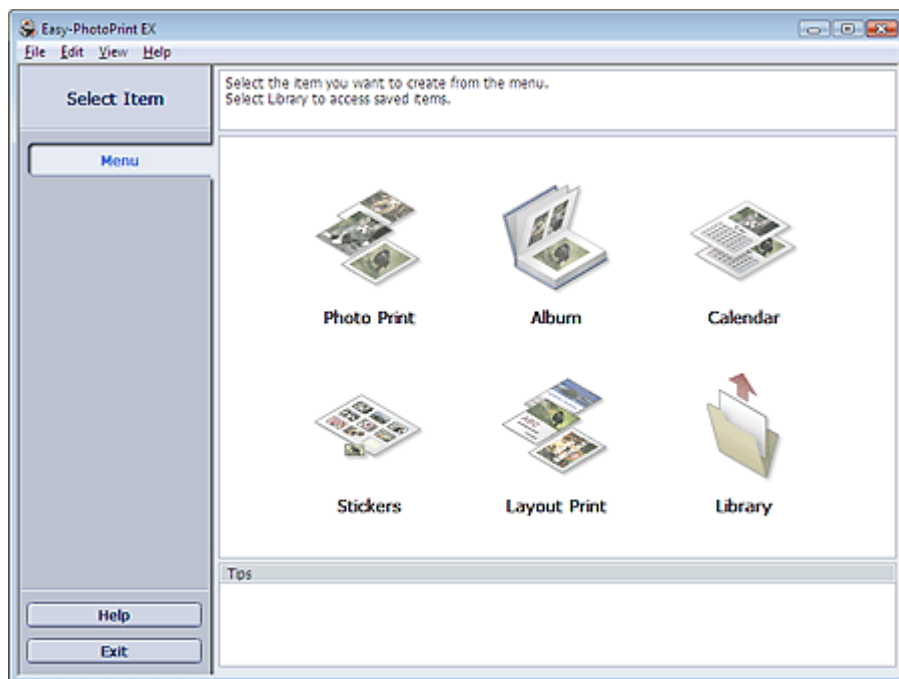

[Page top](#)↑

## Advanced Guide

Advanced Guide > Printing from a Computer > Printing with the Bundled Application Software > Printing Calendars > Selecting the Paper and Layout

## Selecting the Paper and Layout

### 1. Click Calendar from Menu.

The Page Setup screen appears.

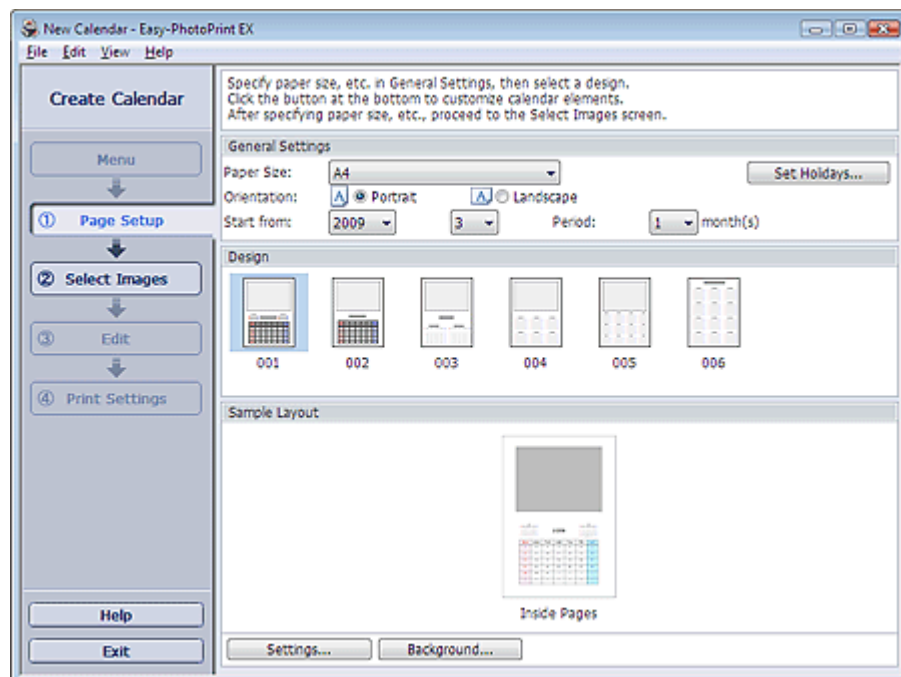

### 2. Set the following items in the General Settings section:

Paper Size

Orientation

Start from

Period



#### Note

- See Help on the paper size that can be selected.
- You can add holidays to your calendar.  
➔ [Setting Holidays](#)

### 3. Select a layout.

If necessary, make advanced settings on the calendar and set the background.



#### Note

- You can customize the calendar display (font colors of the dates and days of the week, position and size of the calendar, etc.).  
➔ [Setting Calendar Display](#)
- You can paint the background in a single color or paste an image file to it in the Change Background dialog box. To display the Change Background dialog box, click Background....



#### Note

- See Help for details on the Page Setup screen.



## Advanced Guide

Advanced Guide > Printing from a Computer > Printing with the Bundled Application Software > Printing Calendars > Selecting a Photo

### Selecting a Photo

#### 1. Click Select Images.

The Select Images screen appears.



#### 2. Select the folder that contains the image you want to print from the folder tree area.

The images in the folder will be displayed as thumbnails (miniatures).

#### 3. Select the image(s) you want to print and click (Import to Inside Pages).

The selected images are displayed in the selected image area.

You can also select the image(s) you want to print by dragging them into the selected image area.

#### Note

- To delete an image in the selected image area, select the image you want to delete and click



(Delete Imported Image).

To delete all images from the selected image area, click  (Delete All Imported Images).

#### Note

- See Help for details on the Select Images screen.





## Advanced Guide

Advanced Guide > Printing from a Computer > Printing with the Bundled Application Software > Printing Calendars > Editing

## Editing

### 1. Click Edit.

The Edit screen appears.

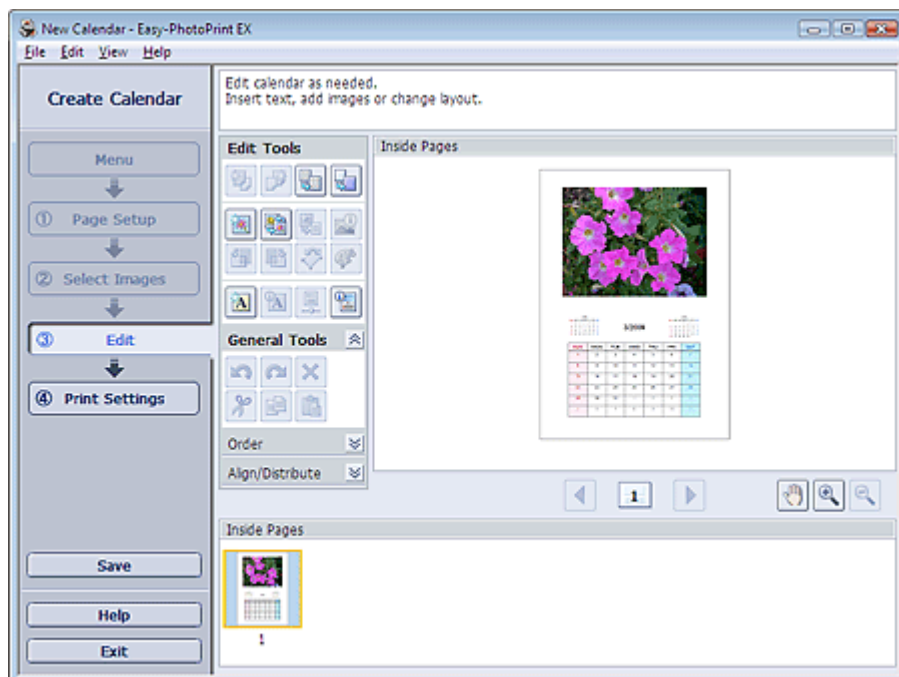

### 2. Edit the calendar if necessary.

- ➔ Changing Layout
- ➔ Changing Background
- ➔ Adding Photos
- ➔ Swapping Positions of Photos
- ➔ Replacing Photos
- ➔ Changing Position, Angle and Size of Photos
- ➔ Cropping Photos
- ➔ Framing Photos
- ➔ Printing Dates on Photos
- ➔ Adding Text to Photos
- ➔ Setting Calendar Display
- ➔ Setting Holidays

#### Note

- The edit information will be discarded if you exit Easy-PhotoPrint EX without saving the edited calendar. It is recommended that you save the item if you want to edit it again.
  - ➔ Saving
- See Help for details on the Edit screen.



## Advanced Guide

Advanced Guide > Printing from a Computer > Printing with the Bundled Application Software > Printing Calendars > Printing

## Printing

### 1. Click Print Settings.

The Print Settings screen appears.

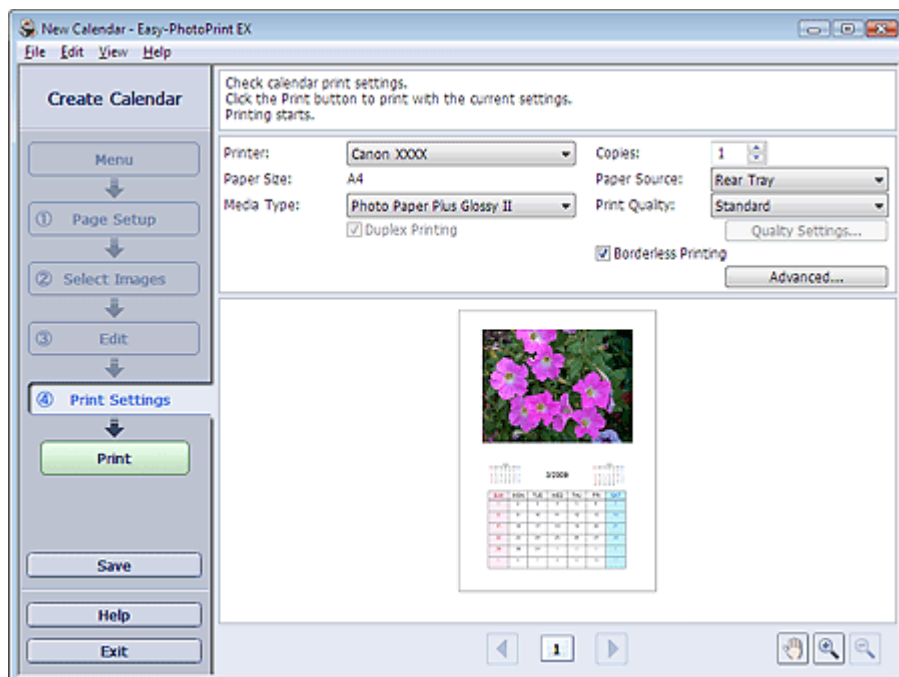

### 2. Set the following items according to the printer and paper to be used:

Printer

Media Type

Copies

Paper Source

Print Quality

Borderless Printing



#### Note

- The media types may vary depending on the printer and the paper size.
- Duplex Printing appears if the selected printer and media type support duplex printing. Select this checkbox to print on both sides of the paper.
- Automatic appears if you select the Duplex Printing checkbox after selecting a printer that supports automatic duplex printing and media type that supports duplex printing. Select this checkbox to print on both sides of the paper automatically.
- The paper sources may vary depending on the printer and the media type.
- You can set a custom print quality level in the Print Quality Settings dialog box. To display the Print Quality Settings dialog box, select Custom for Print Quality and click Quality Settings....
- You can specify the print range and the amount of extension for borderless printing in the Print Settings dialog box. To display the Print Settings dialog box, click Advanced....

### 3. Click Print.



#### Note

- See Help for details on the Print Settings screen.



## Advanced Guide

Advanced Guide > Printing from a Computer > Printing with the Bundled Application Software > Printing Stickers

# Printing Stickers

You can print your favorite photos on compatible sticker sheets.



### Steps

1. Starting Easy-PhotoPrint EX
2. Selecting the Paper and Layout
3. Selecting a Photo
4. Editing
5. Printing

### Try This

- ➔ Correcting and Enhancing Photos
- ➔ Adding Photos
- ➔ Swapping Positions of Photos
- ➔ Replacing Photos
- ➔ Changing Position, Angle and Size of Photos
- ➔ Cropping Photos
- ➔ Framing Photos
- ➔ Adding Text to Photos
- ➔ Saving
- ➔ Opening Saved Files

### Questions and Answers

- ➔ How Can I Move (or Copy) the Saved File?

## Advanced Guide

Advanced Guide > Printing from a Computer > Printing with the Bundled Application Software > Printing Stickers > Starting Easy-PhotoPrint EX

## Starting Easy-PhotoPrint EX

1. From the Start menu, select (All) Programs > Canon Utilities > Easy-PhotoPrint EX > Easy-PhotoPrint EX.

Easy-PhotoPrint EX starts and Menu appears.

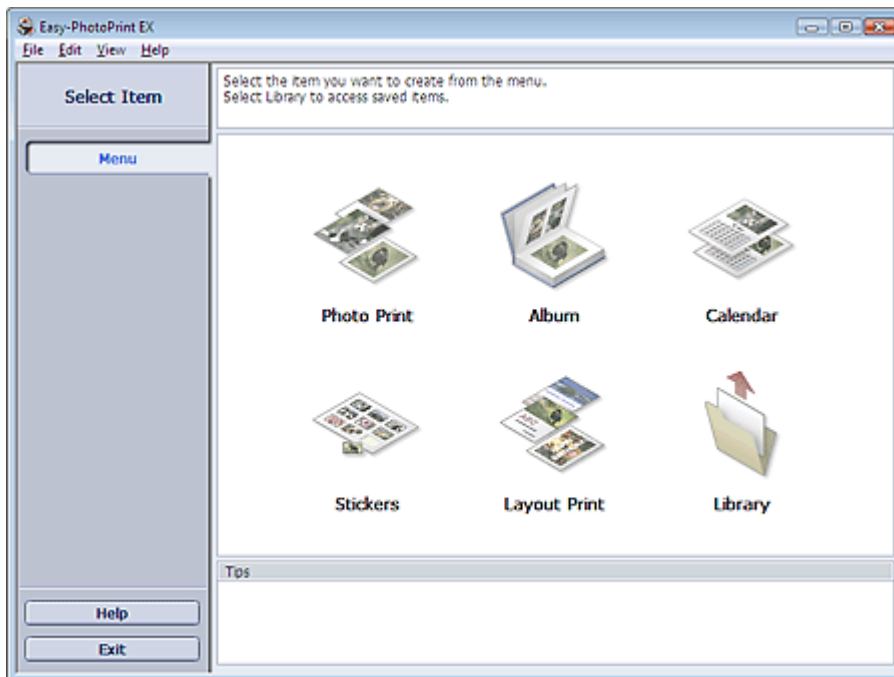

[Page top](#)↑

## Advanced Guide

Advanced Guide > Printing from a Computer > Printing with the Bundled Application Software > Printing Stickers > Selecting the Paper and Layout

# Selecting the Paper and Layout

## 1. Click Stickers from Menu.

The Page Setup screen appears.

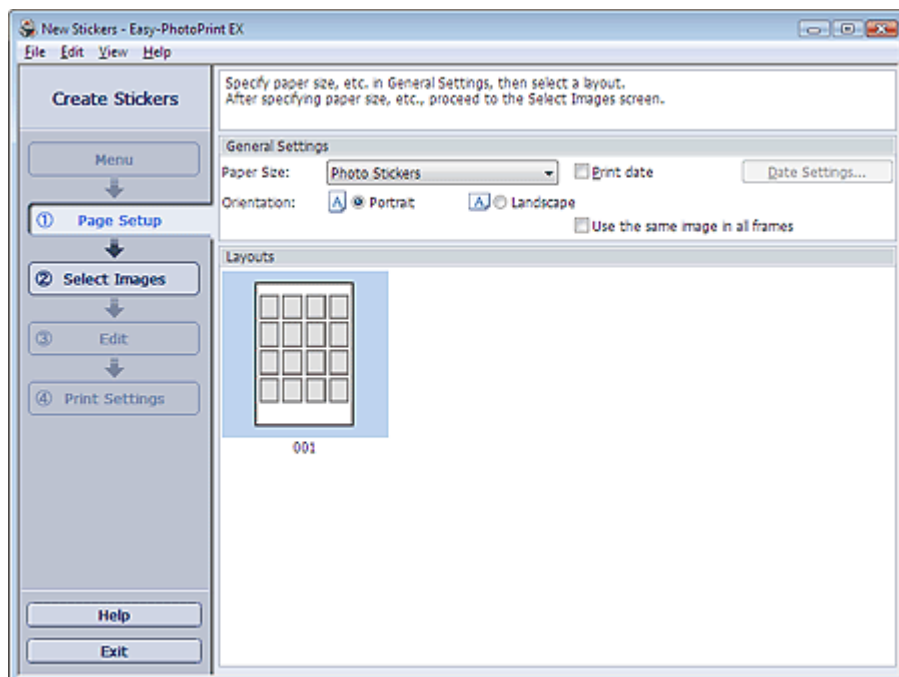

## 2. Set the following items in the General Settings section:

Paper Size

Orientation

Print date

Use the same image in all frames



### Note

- Paper sizes other than Photo Stickers cannot be selected.
- Select the Use the same image in all frames checkbox to use the same image in all the frames on the page.
- You can customize the date (position, size and color) in the Date Settings dialog box. To display the Date Settings dialog box, select the Print date checkbox and click Date Settings....



### Note

- See Help for details on the Page Setup screen.



## Advanced Guide

Advanced Guide > Printing from a Computer > Printing with the Bundled Application Software > Printing Stickers > Selecting a Photo

### Selecting a Photo

#### 1. Click Select Images.

The Select Images screen appears.



#### 2. Select the folder that contains the image you want to print from the folder tree area.

The images in the folder will be displayed as thumbnails (miniatures).

#### 3. Select the image(s) you want to print and click (Import to Inside Pages).

The selected images are displayed in the selected image area.

You can also select the image(s) you want to print by dragging them into the selected image area.

#### Note

- To delete an image in the selected image area, select the image you want to delete and click



(Delete Imported Image).

To delete all images from the selected image area, click  (Delete All Imported Images).

#### Note

- See Help for details on the Select Images screen.



## Advanced Guide

Advanced Guide > Printing from a Computer > Printing with the Bundled Application Software > Printing Stickers > Editing

## Editing

### 1. Click Edit.

The Edit screen appears.

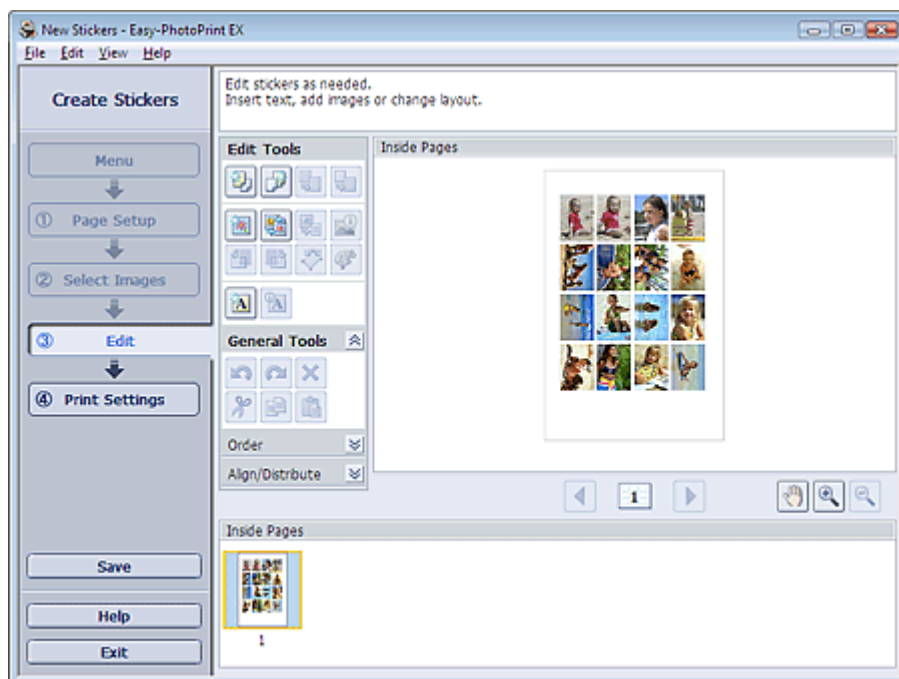

### 2. Edit the stickers if necessary.

- ➔ Adding Photos
- ➔ Swapping Positions of Photos
- ➔ Replacing Photos
- ➔ Changing Position, Angle and Size of Photos
- ➔ Cropping Photos
- ➔ Printing Dates on Photos
- ➔ Adding Text to Photos

#### Note

- The edit information will be discarded if you exit Easy-PhotoPrint EX without saving the edited stickers. It is recommended that you save the item if you want to edit it again.
  - ➔ Saving
- See Help for details on the Edit screen.



[Page top](#)↑

## Advanced Guide

Advanced Guide > Printing from a Computer > Printing with the Bundled Application Software > Printing Stickers > Printing

## Printing

### 1. Click Print Settings.

The Print Settings screen appears.

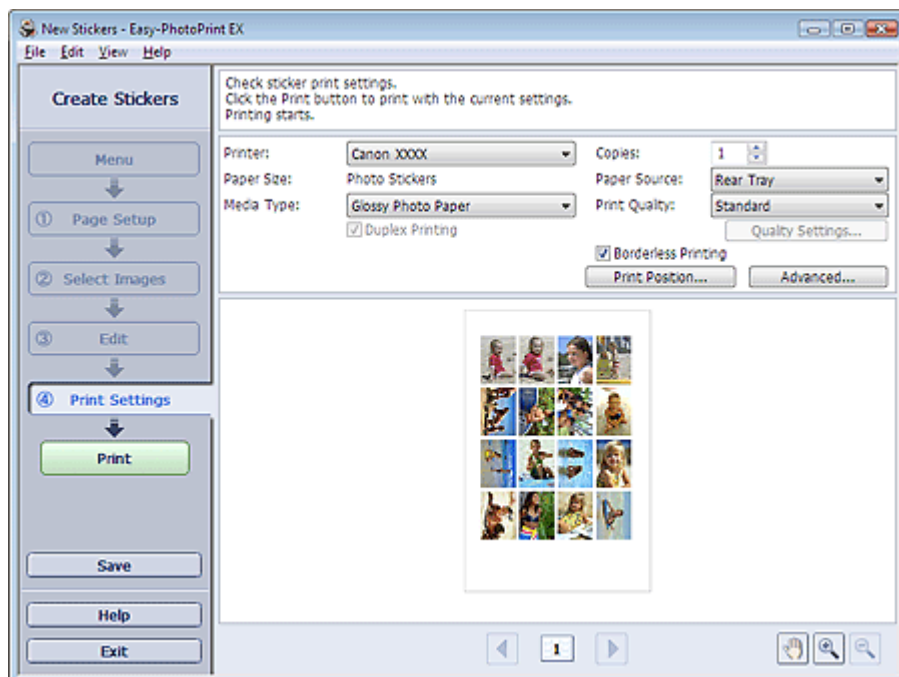

### 2. Set the following items according to the printer and paper to be used:

Printer

Media Type

Copies

Paper Source

Print Quality

Borderless Printing



#### Note

- The media types may vary depending on the printer and the paper size.
- The paper sources may vary depending on the printer and the media type.
- You can set a custom print quality level in the Print Quality Settings dialog box. To display the Print Quality Settings dialog box, select Custom for Print Quality and click Quality Settings....
- You can adjust the printing position in the Adjust Print Position dialog box. To display the Adjust Print Position dialog box, click Print Position....
- You can specify the print range and the amount of extension for borderless printing in the Print Settings dialog box. To display the Print Settings dialog box, click Advanced....

### 3. Click Print.



#### Note

- See Help for details on the Print Settings screen.





## Advanced Guide

Advanced Guide > Printing from a Computer > Printing with the Bundled Application Software > Printing Layout

# Printing Layout

You can add text to your favorite photos and print them in a variety of layouts.



### Steps

1. Starting Easy-PhotoPrint EX
2. Selecting the Paper and Layout
3. Selecting a Photo
4. Editing
5. Printing

### Try This

- ➔ Correcting and Enhancing Photos
- ➔ Changing Layout
- ➔ Adding Photos
- ➔ Swapping Positions of Photos
- ➔ Replacing Photos
- ➔ Changing Position, Angle and Size of Photos
- ➔ Cropping Photos
- ➔ Printing Dates on Photos
- ➔ Adding Text to Photos
- ➔ Saving
- ➔ Opening Saved Files

### Questions and Answers

- ➔ How Can I Move (or Copy) the Saved File?

## Advanced Guide

Advanced Guide > Printing from a Computer > Printing with the Bundled Application Software > Printing Layout > Starting Easy-PhotoPrint EX

### Starting Easy-PhotoPrint EX

1. From the Start menu, select (All) Programs > Canon Utilities > Easy-PhotoPrint EX > Easy-PhotoPrint EX.

Easy-PhotoPrint EX starts and Menu appears.

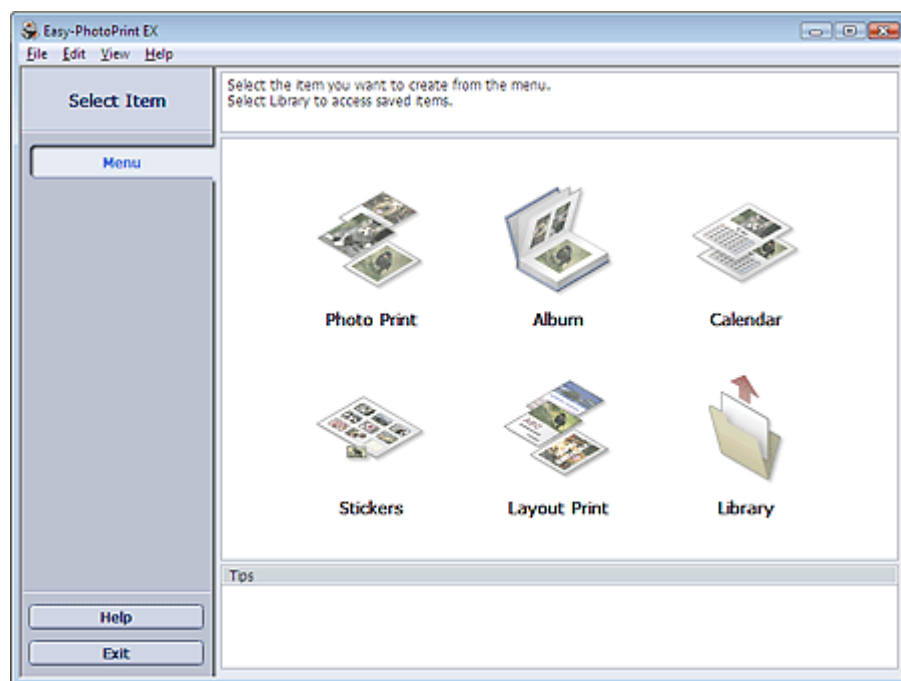

[Page top](#)↑

## Advanced Guide

Advanced Guide > Printing from a Computer > Printing with the Bundled Application Software > Printing Layout > Selecting the Paper and Layout

# Selecting the Paper and Layout

## 1. Click Layout Print from Menu.

The Page Setup screen appears.

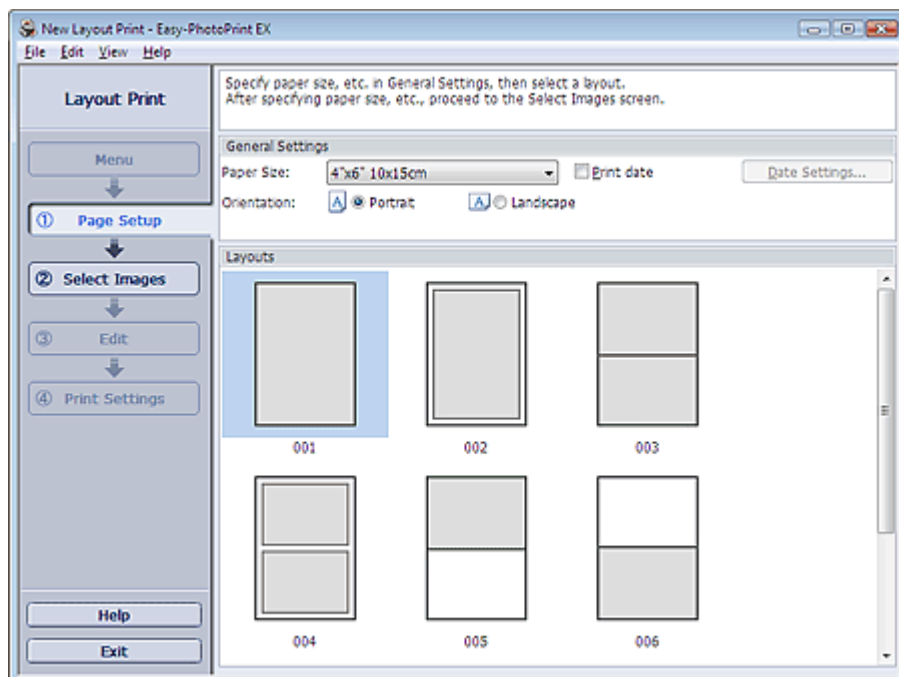

## 2. Set the following items in the General Settings section:

Paper Size

Orientation

Print date



### Note

- See Help on the paper size that can be selected.
- You can customize the date (position, size and color) in the Date Settings dialog box. To display the Date Settings dialog box, select the Print date checkbox and click Date Settings....

## 3. Select a layout from Layouts.



### Note

- The layouts displayed may vary depending on the Orientation.



### Note

- See Help for details on the Page Setup screen.



## Advanced Guide

Advanced Guide > Printing from a Computer > Printing with the Bundled Application Software > Printing Layout > Selecting a Photo

### Selecting a Photo

#### 1. Click Select Images.

The Select Images screen appears.

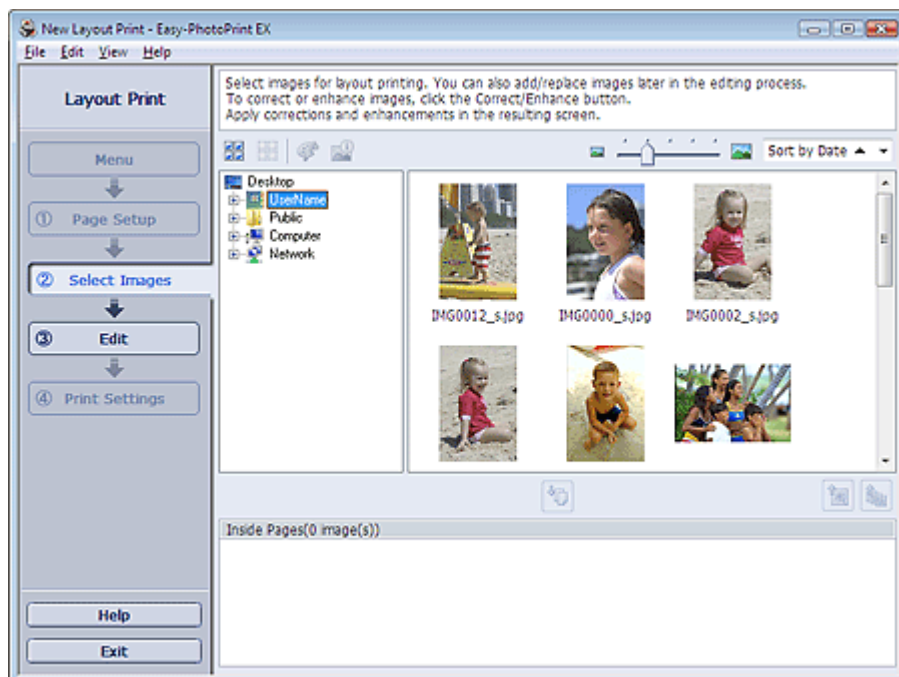

#### 2. Select the folder that contains the image you want to print from the folder tree area.

The images in the folder will be displayed as thumbnails (miniatures).

#### 3. Select the image(s) you want to print and click (Import to Inside Pages).

The selected images are displayed in the selected image area.

You can also select the image(s) you want to print by dragging them into the selected image area.

#### Note

- To delete an image in the selected image area, select the image you want to delete and click



(Delete Imported Image).

To delete all images from the selected image area, click  (Delete All Imported Images).

#### Note

- See Help for details on the Select Images screen.



## Advanced Guide

Advanced Guide > Printing from a Computer > Printing with the Bundled Application Software > Printing Layout > Editing

## Editing

### 1. Click Edit.

The Edit screen appears.

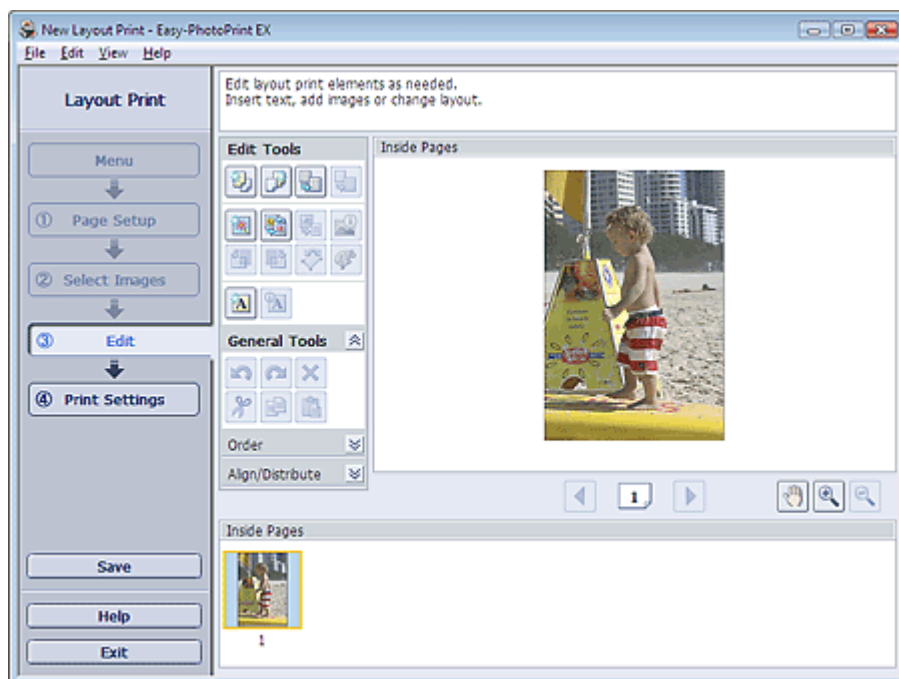

### 2. Edit the layout if necessary.

- ➔ Changing Layout
- ➔ Adding Photos
- ➔ Swapping Positions of Photos
- ➔ Replacing Photos
- ➔ Changing Position, Angle and Size of Photos
- ➔ Cropping Photos
- ➔ Printing Dates on Photos
- ➔ Adding Text to Photos

#### Note

- The edit information will be discarded if you exit Easy-PhotoPrint EX without saving the edited layout. It is recommended that you save the item if you want to edit it again.
  - ➔ Saving
- See Help for details on the Edit screen.



## Advanced Guide

Advanced Guide > Printing from a Computer > Printing with the Bundled Application Software > Printing Layout > Printing

## Printing

### 1. Click Print Settings.

The Print Settings screen appears.

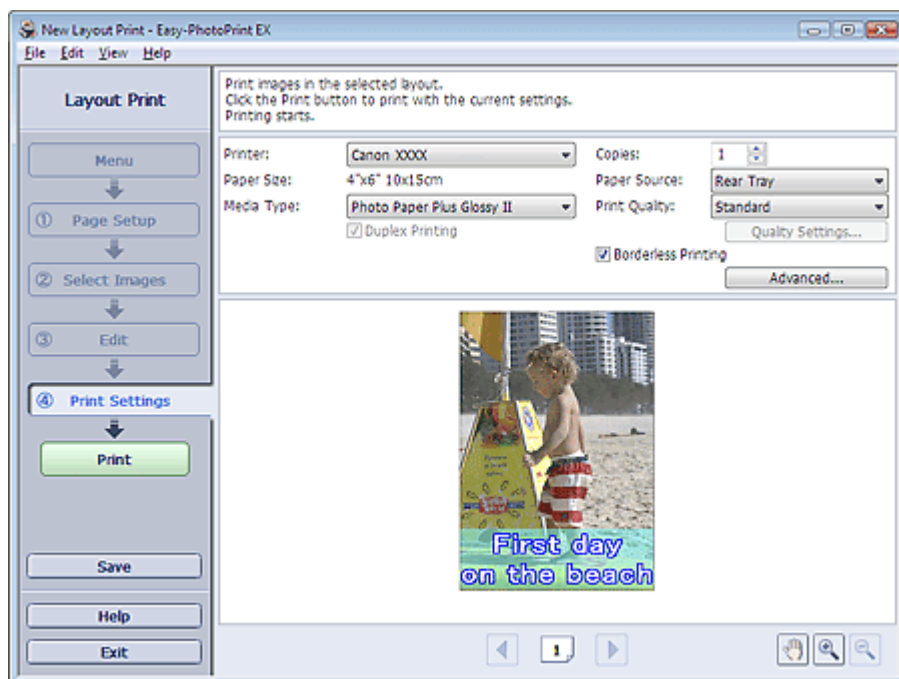

### 2. Set the following items according to the printer and paper to be used:

Printer

Media Type

Copies

Paper Source

Print Quality

Borderless Printing

#### Note

- The media types may vary depending on the printer and the paper size.
- Duplex Printing appears if the selected printer and media type support duplex printing. Select this checkbox to print on both sides of the paper.
- Automatic appears if you select the Duplex Printing checkbox after selecting a printer that supports automatic duplex printing and media type that supports duplex printing. Select this checkbox to print on both sides of the paper automatically.
- The paper sources may vary depending on the printer and the media type.
- You can set a custom print quality level in the Print Quality Settings dialog box. To display the Print Quality Settings dialog box, select Custom for Print Quality and click Quality Settings....
- Select the Borderless Printing checkbox to print borderless photos.
- You can specify the print range and the amount of extension for borderless printing in the Print Settings dialog box. To display the Print Settings dialog box, click Advanced....

### 3. Click Print.

#### Note

- See Help for details on the Print Settings screen.



## Advanced Guide

Advanced Guide > Printing from a Computer > Printing with the Bundled Application Software > Correcting and Enhancing Photos

# Correcting and Enhancing Photos

You can correct and enhance images.

Click  (Correct/Enhance Images) in the Select Images or Edit screen, or in the Layout/Print screen of Photo Print. You can make the following corrections and enhancements in the Correct/Enhance Images window.

### Important

- For Photo Print, if you select Enable ICC Profile in the Advanced tab of the Preferences dialog box, you cannot correct/enhance images.

### Note

- See "[Correct/Enhance Images Window](#)" for details on the Correct/Enhance Images window.

### Auto Photo Fix

This function will automatically analyze the captured scene and apply suitable corrections.

➔ [Using the Auto Photo Fix Function](#)

### Red-Eye Correction Function

You can correct red eyes caused by a camera flash.

➔ [Using the Red-Eye Correction Function](#)

### Face Brightener Function

You can brighten dark faces caused by bright background.

➔ [Using the Face Brightener Function](#)

### Face Sharpener Function

You can sharpen out-of-focus faces in a photo.

➔ [Using the Face Sharpener Function](#)

### Digital Face Smoothing Function

You can enhance skin beautifully by removing blemishes and wrinkles.

➔ [Using the Digital Face Smoothing Function](#)

### Blemish Remover Function

You can remove moles.

➔ [Using the Blemish Remover Function](#)

### Image Adjustment

You can make fine adjustments to the overall brightness, contrast, etc. of images.

➔ [Adjusting Images](#)

## Advanced Guide

Advanced Guide > Printing from a Computer > Printing with the Bundled Application Software > Correcting and Enhancing Photos > Using the Auto Photo Fix Function

### Using the Auto Photo Fix Function

Apply optimum corrections automatically to the photos used for an album or calendar.

#### Important

- The Auto Photo Fix function is not available for Photo Print. Photo Print allows you to automatically apply suitable corrections to all photos when printing. Select this option in Image on the Advanced tab of the Preferences dialog box. To display the Preferences dialog box, click  (Settings) in the Layout/Print screen or select Preferences... from the File menu.
- Once image is corrected with Auto Photo Fix and saved, it cannot be corrected again with Auto Photo Fix.  
Also, Auto Photo Fix may not be available for images edited using an application, digital camera, etc. manufactured by other companies.

1. Select photos in the Select Images screen, then click  (Correct/Enhance Images).

The Correct/Enhance Images window appears.

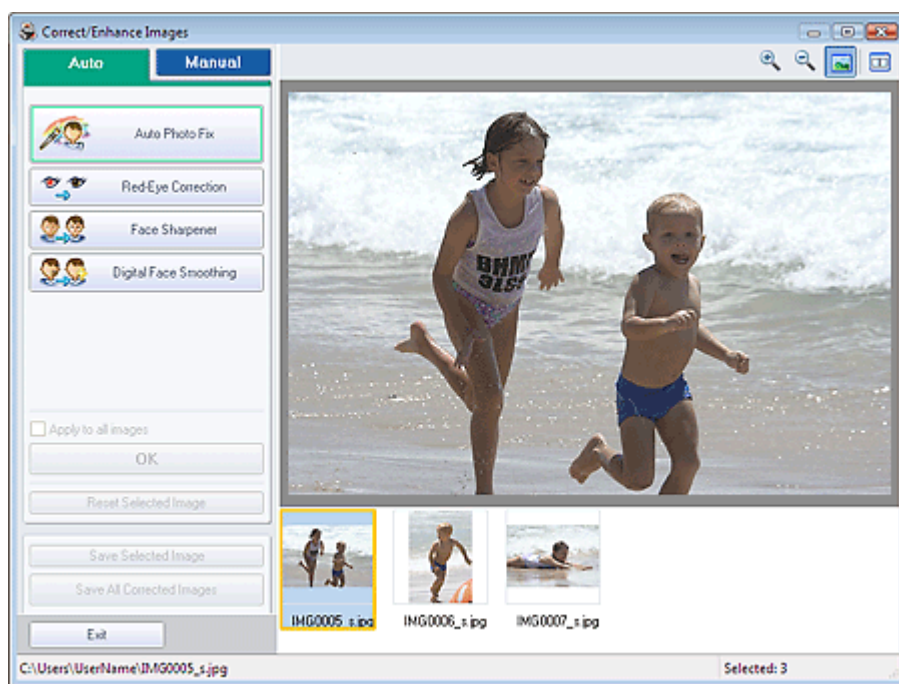

#### Note

- You can also display the Correct/Enhance Images window by clicking  (Correct/Enhance Images) in the Layout/Print or Edit screen. In that case, only the image displayed in Preview can be corrected/enhanced.
- See "[Correct/Enhance Images Window](#)" for details on the Correct/Enhance Images window.

2. Select the image you want to correct from the list displayed in the lower part of the Correct/Enhance Images window.

The image appears in Preview.

#### Note

- If only one image is selected, the thumbnail does not appear below Preview.

3. Make sure that Auto is selected.



#### 4. Click Auto Photo Fix, then click OK.

The entire photo is corrected automatically and the  (Correction/Enhancement) mark appears on the upper left of the image.

##### Note

---

- Click  (Compare) to display the images before and after the correction side by side so that you can compare and check the result.
  - Click Reset Selected Image to undo the correction operation.
  - If you want to apply the correction to all the selected images at once, select the Apply to all images checkbox.
- 

#### 5. Click Save Selected Image or Save All Corrected Images.

You can save corrected images as new files.

##### Note

---

- To save only the image you like, click Save Selected Image. To save all images, click Save All Corrected Images.
  - Only JPEG/Exif file format is available for corrected images.
- 

#### 6. Click Exit.

##### Note

---

- The corrections will be lost if you exit before saving corrected images.
-

## Advanced Guide

Advanced Guide > Printing from a Computer > Printing with the Bundled Application Software > Correcting and Enhancing Photos > Using the Red-Eye Correction Function

### Using the Red-Eye Correction Function

You can correct red eyes caused by a camera flash.

You can perform the Red-Eye Correction function either automatically or manually.

#### Note

- Photo Print allows you to automatically correct red eyes when printing. To correct automatically, select Enable Auto Photo Fix in Color correction for printing on the Advanced tab of the Preferences dialog box and select the Enable Red-Eye Correction checkbox.

- Select photos in the Select Images screen, then click  (Correct/Enhance Images).

The Correct/Enhance Images window appears.

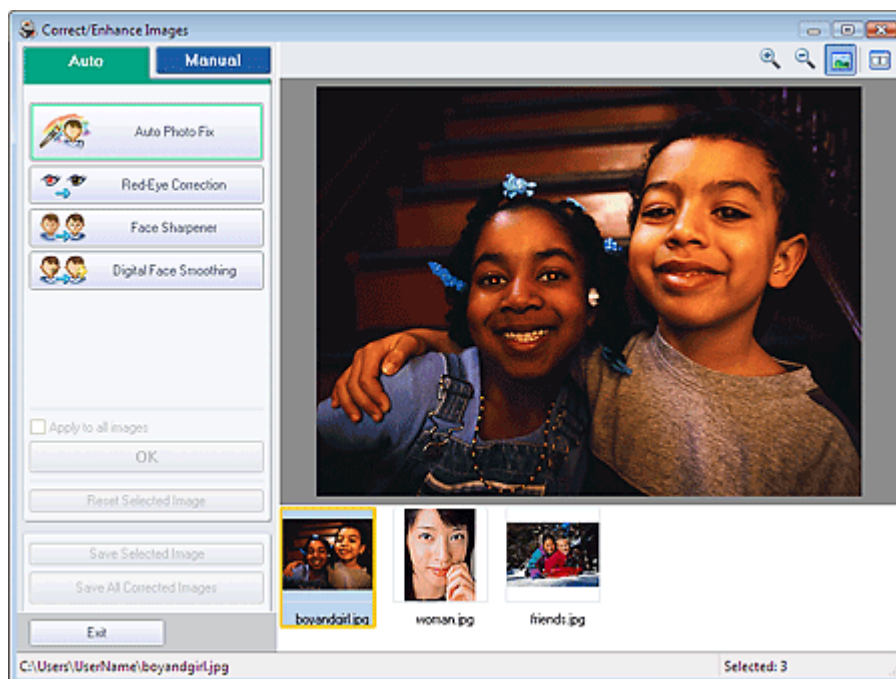

#### Note

- You can also display the Correct/Enhance Images window by clicking  (Correct/Enhance Images) in the Layout/Print or Edit screen. In that case, only the image displayed in Preview can be corrected/enhanced.
- See "[Correct/Enhance Images Window](#)" for details on the Correct/Enhance Images window.

- Select the image you want to correct from the list displayed in the lower part of the Correct/Enhance Images window.

The image appears in Preview.

#### Note

- If only one image is selected, the thumbnail does not appear below Preview.

#### Auto Correction

- Make sure that Auto is selected.
- Click Red-Eye Correction.

**5.** Click OK.

Red eyes are corrected and the  (Correction/Enhancement) mark appears on the upper left of the image.

**Important**

- Areas other than the eyes may be corrected depending on the image.

**Note**

- Click  (Compare) to display the images before and after the correction side by side so that you can compare and check the result.
- Click Reset Selected Image to undo the correction operation.
- If you want to apply the correction to all the selected images at once, select the Apply to all images checkbox.

**Manual Correction****3.** Click Manual, then click Correct/Enhance.**4.** Click Red-Eye Correction.

Move the cursor over the image. The shape of the cursor changes to  (Paintbrush).

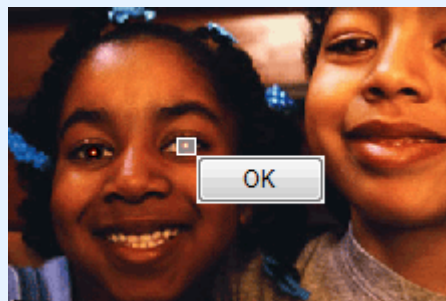
**5.** Drag to select the red area you want to correct, then click OK that appears over the image.

Red eye is corrected and the  (Correction/Enhancement) mark appears on the upper left of the image.

**Note**

- Click Undo to undo the preceding correction operation.
- Effect levels can be changed using the slider below Red-Eye Correction.

## 6. Click Save Selected Image or Save All Corrected Images.

You can save corrected images as new files.

### Note

---

- To save only the image you like, click Save Selected Image. To save all images, click Save All Corrected Images.
  - Only JPEG/Exif file format is available for corrected images.
- 

## 7. Click Exit.

### Note

---

- The corrections will be lost if you exit before saving corrected images.
- 

[Page top](#)↑

## Advanced Guide

Advanced Guide > Printing from a Computer > Printing with the Bundled Application Software > Correcting and Enhancing Photos > Using the Face Brightener Function

### Using the Face Brightener Function

You can brighten dark faces caused by bright background.

1. Select photos in the Select Images screen, then click  (Correct/Enhance Images).

The Correct/Enhance Images window appears.

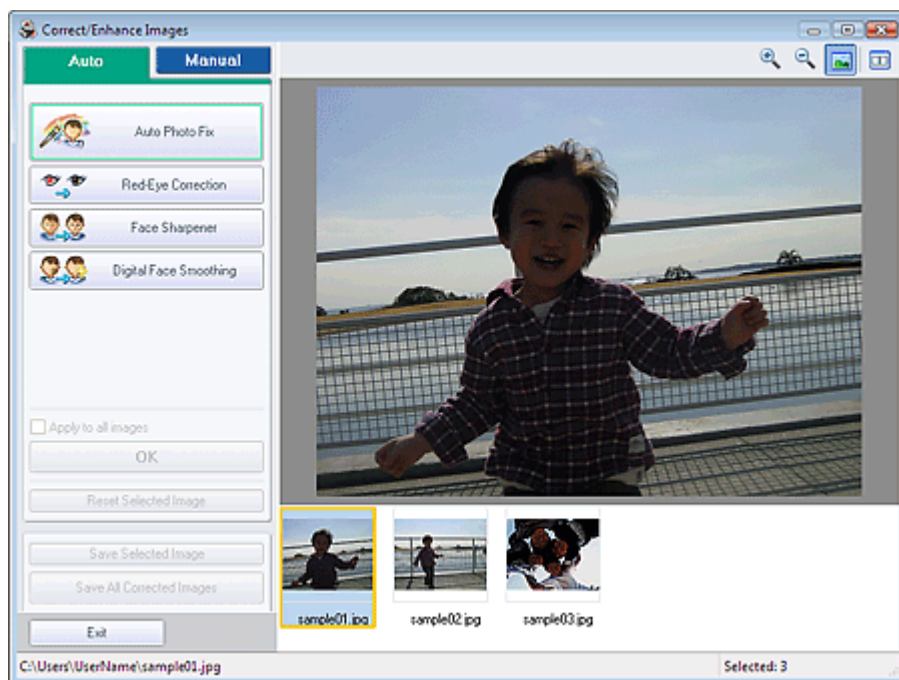

#### Note

- You can also display the Correct/Enhance Images window by clicking  (Correct/Enhance Images) in the Layout/Print or Edit screen. In that case, only the image displayed in Preview can be corrected/enhanced.
- See "[Correct/Enhance Images Window](#)" for details on the Correct/Enhance Images window.

2. Select the image you want to correct from the list displayed in the lower part of the Correct/Enhance Images window.

The image appears in Preview.

#### Note

- If only one image is selected, the thumbnail does not appear below Preview.

3. Click Manual, then click Correct/Enhance.

4. Click Face Brightener.

Move the cursor over the image. The shape of the cursor changes to  (Cross).



5. Drag to select the area you want to correct, then click OK that appears over the image.

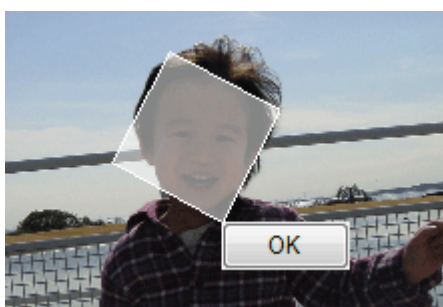

The entire image is corrected so that the selected area containing the face becomes brighter, and the 🗑️ (Correction/Enhancement) mark appears on the upper left of the image.

#### Note

- You can also drag to rotate the rectangle.
- Click Undo to undo the preceding correction operation.
- Effect levels can be changed using the slider below Face Brightener.

6. Click Save Selected Image or Save All Corrected Images.

You can save corrected images as new files.

#### Note

- To save only the image you like, click Save Selected Image. To save all images, click Save All Corrected Images.
- Only JPEG/Exif file format is available for corrected images.

7. Click Exit.

#### Note

- The corrections will be lost if you exit before saving corrected images.

## Advanced Guide

Advanced Guide > Printing from a Computer > Printing with the Bundled Application Software > Correcting and Enhancing Photos > Using the Face Sharpener Function

### Using the Face Sharpener Function

You can sharpen out-of-focus faces in a photo.

You can perform the Face Sharpener function either automatically or manually.

1. Select photos in the Select Images screen, then click  (Correct/Enhance Images).

The Correct/Enhance Images window appears.

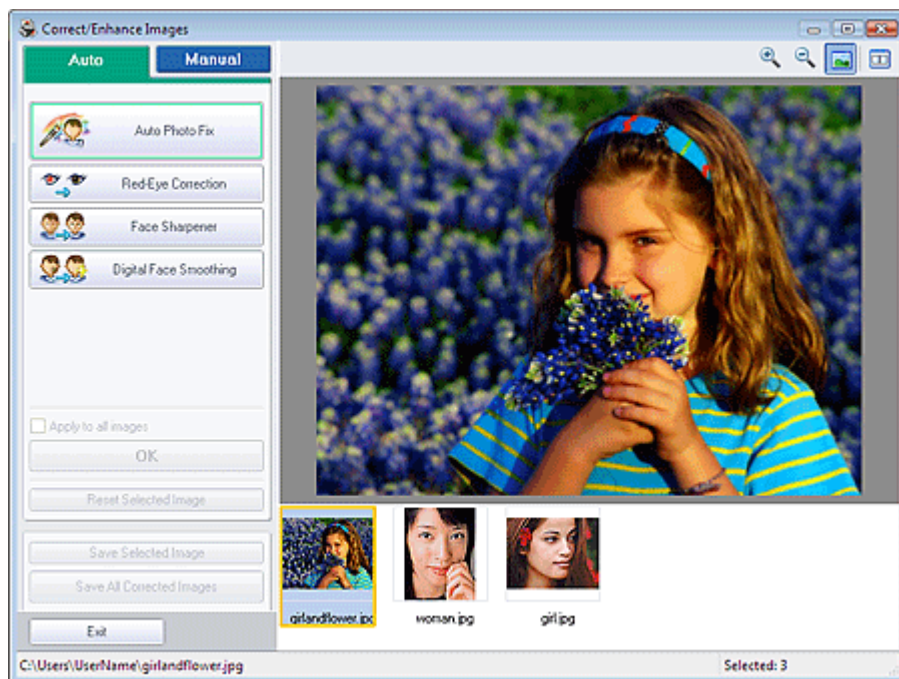

#### Note

- You can also display the Correct/Enhance Images window by clicking  (Correct/Enhance Images) in the Layout/Print or Edit screen. In that case, only the image displayed in Preview can be corrected/enhanced.
- See "[Correct/Enhance Images Window](#)" for details on the Correct/Enhance Images window.

2. Select the image you want to correct from the list displayed in the lower part of the Correct/Enhance Images window.

The image appears in Preview.

#### Note

- If only one image is selected, the thumbnail does not appear below Preview.

#### Auto Correction

3. Make sure that Auto is selected.
4. Click Face Sharpener.
5. Click OK.

The face is sharpened and the  (Correction/Enhancement) mark appears on the upper left of the image.

**Note**

- Effect levels can be changed using the slider below Face Sharpener.
- Click  (Compare) to display the images before and after the correction side by side so that you can compare and check the result.
- Click Reset Selected Image to undo the correction operation.
- If you want to apply the correction to all the selected images at once, select the Apply to all images checkbox.

**Manual Correction**

3. Click Manual, then click Correct/Enhance.

4. Click Face Sharpener.

Move the cursor over the image. The shape of the cursor changes to  (Cross).



5. Drag to select the area you want to correct, then click OK that appears over the image.

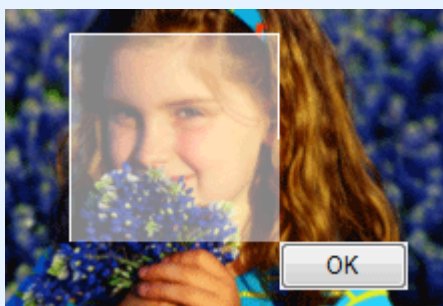

The facial area in and around the selected area is sharpened and the  (Correction/Enhancement) mark appears on the upper left of the image.

**Note**

- You can also drag to rotate the rectangle.
- Click Undo to undo the preceding correction operation.
- Effect levels can be changed using the slider below Face Sharpener.

6. Click Save Selected Image or Save All Corrected Images.

You can save corrected images as new files.

**Note**

- To save only the image you like, click Save Selected Image. To save all images, click Save All Corrected Images.



- Only JPEG/Exif file format is available for corrected images.
- 

## 7. Click Exit.



### Note

- The corrections will be lost if you exit before saving corrected images.
- 

[Page top](#)↑

## Advanced Guide

Advanced Guide > Printing from a Computer > Printing with the Bundled Application Software > Correcting and Enhancing Photos > Using the Digital Face Smoothing Function

### Using the Digital Face Smoothing Function

You can enhance skin beautifully by removing blemishes and wrinkles.

You can perform the Digital Face Smoothing function either automatically or manually.

1. Select photos in the Select Images screen, then click  (Correct/Enhance Images).

The Correct/Enhance Images window appears.



#### Note

- You can also display the Correct/Enhance Images window by clicking  (Correct/Enhance Images) in the Layout/Print or Edit screen. In that case, only the image displayed in Preview can be corrected/enhanced.
- See "[Correct/Enhance Images Window](#)" for details on the Correct/Enhance Images window.

2. Select the image you want to enhance from the list displayed in the lower part of the Correct/Enhance Images window.

The image appears in Preview.

#### Note

- If only one image is selected, the thumbnail does not appear below Preview.

#### Auto Enhancement

3. Make sure that Auto is selected.
4. Click Digital Face Smoothing.
5. Click OK.

Skin is enhanced beautifully and the  (Correction/Enhancement) mark appears on the upper left of the image.

 **Note**

- Effect levels can be changed using the slider below Digital Face Smoothing.
- Click  (Compare) to display the images before and after the enhancement side by side so that you can compare and check the result.
- Click Reset Selected Image to undo the enhancement operation.
- If you want to apply the enhancement to all the selected images at once, select the Apply to all images checkbox.

## Manual Enhancement

3. Click Manual, then click Correct/Enhance.

4. Click Digital Face Smoothing.

Move the cursor over the image. The shape of the cursor changes to  (Cross).

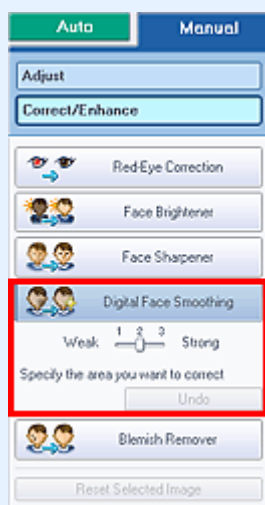

5. Drag to select the area you want to enhance, then click OK that appears over the image.

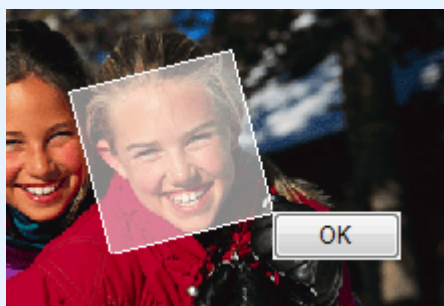

Skin in and around the selected area is enhanced beautifully and the  (Correction/Enhancement) mark appears on the upper left of the image.

 **Note**

- You can also drag to rotate the rectangle.
- Click Undo to undo the preceding enhancement operation.
- Effect levels can be changed using the slider below Digital Face Smoothing.

6. Click Save Selected Image or Save All Corrected Images.

You can save enhanced images as new files.

 **Note**

- To save only the image you like, click Save Selected Image. To save all images, click Save All Corrected Images.

- Only JPEG/Exif file format is available for enhanced images.
- 

## 7. Click Exit.



### Note

- The enhancements will be lost if you exit before saving enhanced images.
- 

[Page top](#)↑

## Advanced Guide

Advanced Guide > Printing from a Computer > Printing with the Bundled Application Software > Correcting and Enhancing Photos > Using the Blemish Remover Function

### Using the Blemish Remover Function

You can remove moles.

1. Select photos in the Select Images screen, then click  (Correct/Enhance Images).

The Correct/Enhance Images window appears.

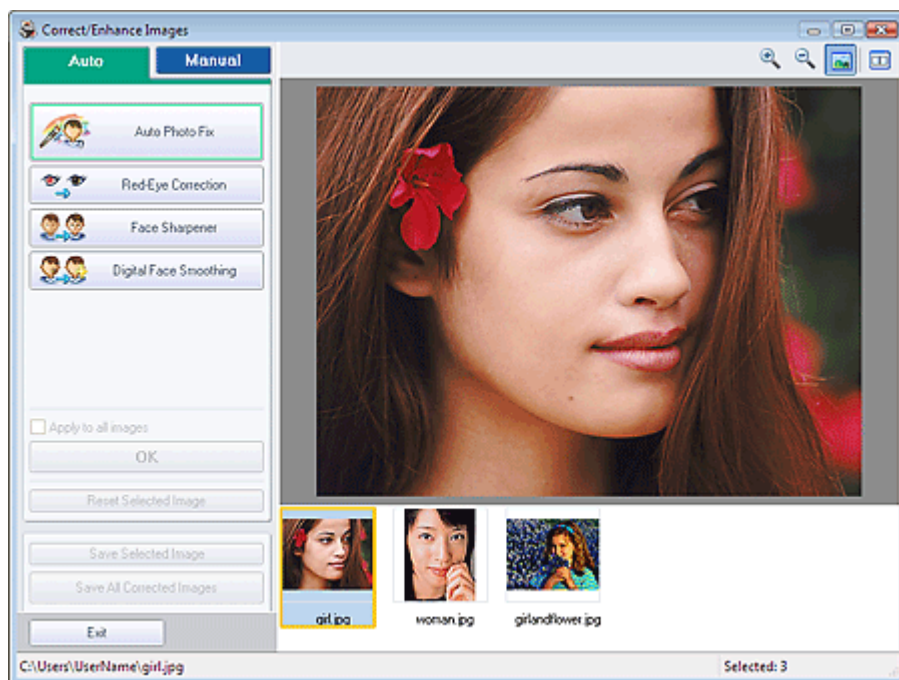

#### Note

- You can also display the Correct/Enhance Images window by clicking  (Correct/Enhance Images) in the Layout/Print or Edit screen. In that case, only the image displayed in Preview can be corrected/enhanced.
- See "[Correct/Enhance Images Window](#)" for details on the Correct/Enhance Images window.

2. Select the image you want to enhance from the list displayed in the lower part of the Correct/Enhance Images window.

The image appears in Preview.

#### Note

- If only one image is selected, the thumbnail does not appear below Preview.

3. Click Manual, then click Correct/Enhance.

4. Click Blemish Remover.

Move the cursor over the image. The shape of the cursor changes to  (Cross).

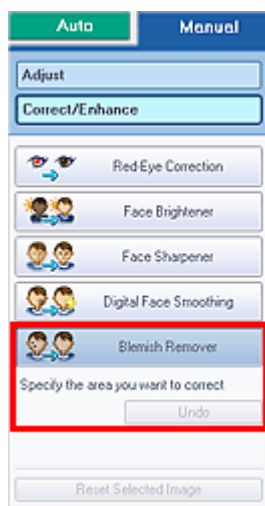

5. Drag to select the area you want to enhance, then click OK that appears over the image.

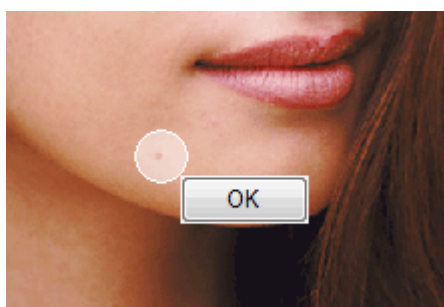

Moles in and around the selected area are removed and the 🧑🏻 (Correction/Enhancement) mark appears on the upper left of the image.

#### Note

- Click Undo to undo the preceding enhancement operation.

6. Click Save Selected Image or Save All Corrected Images.

You can save enhanced images as new files.

#### Note

- To save only the image you like, click Save Selected Image. To save all images, click Save All Corrected Images.
- Only JPEG/Exif file format is available for enhanced images.

7. Click Exit.

#### Note

- The enhancements will be lost if you exit before saving enhanced images.

## Advanced Guide

Advanced Guide > Printing from a Computer > Printing with the Bundled Application Software > Correcting and Enhancing Photos > Adjusting Images

## Adjusting Images

You can make fine adjustments to the overall brightness, contrast, etc. of images.

1. Select photos in the Select Images screen, then click  (Correct/Enhance Images).

The Correct/Enhance Images window appears.

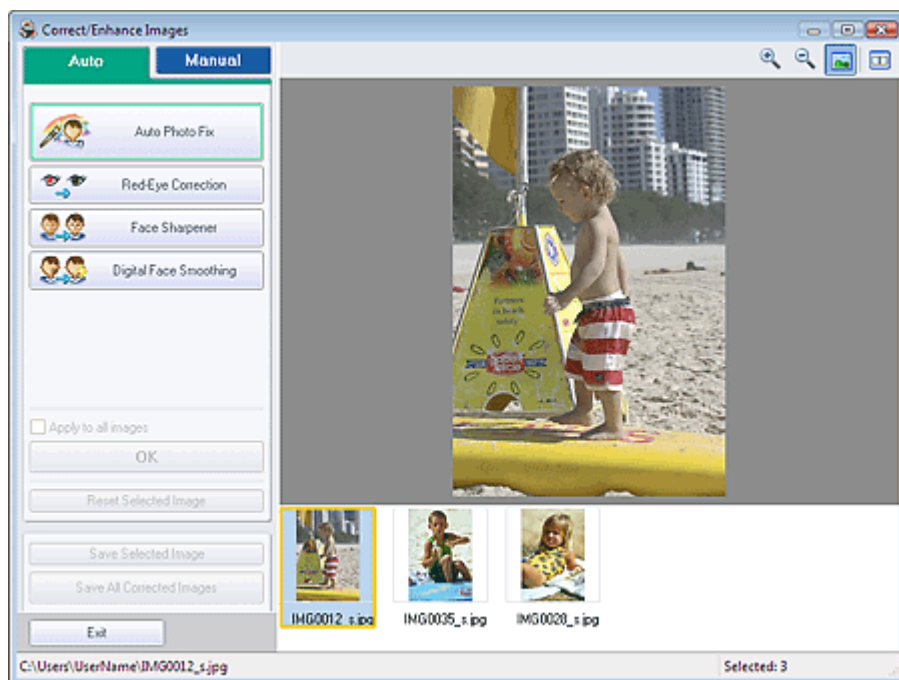

### Note

- You can also display the Correct/Enhance Images window by clicking  (Correct/Enhance Images) in the Layout/Print or Edit screen. In that case, only the image displayed in Preview can be corrected/enhanced.
- See "[Correct/Enhance Images Window](#)" for details on the Correct/Enhance Images window.

2. Select the image you want to adjust from the list displayed in the lower part of the Correct/Enhance Images window.

The image appears in Preview.

### Note

- If only one image is selected, the thumbnail does not appear below Preview.

3. Click Manual, then click Adjust.

4. Move the slider of the item you want to adjust and set the effect level.

The following adjustments are available:

Brightness

Contrast

Sharpness

Blur

Show-through Removal

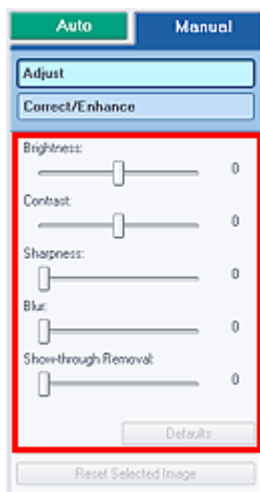
**Note**

- Click Defaults to reset all adjustments.

**5.** Click Save Selected Image or Save All Corrected Images.

You can save adjusted images as new files.

**Note**

- To save only the image you like, click Save Selected Image. To save all images, click Save All Corrected Images.
- Only JPEG/Exif file format is available for adjusted images.

**6.** Click Exit.**Note**

- The adjustments will be lost if you exit before saving adjusted images.



## Advanced Guide

Advanced Guide > Printing from a Computer > Printing with the Bundled Application Software > Correcting and Enhancing Photos > Correct/Enhance Images Window

## Correct/Enhance Images Window

You can correct/enhance images in this window.

To display the Correct/Enhance Images window, click  (Correct/Enhance Images) in the Select Images or Edit screen, or in the Layout/Print screen of Photo Print.

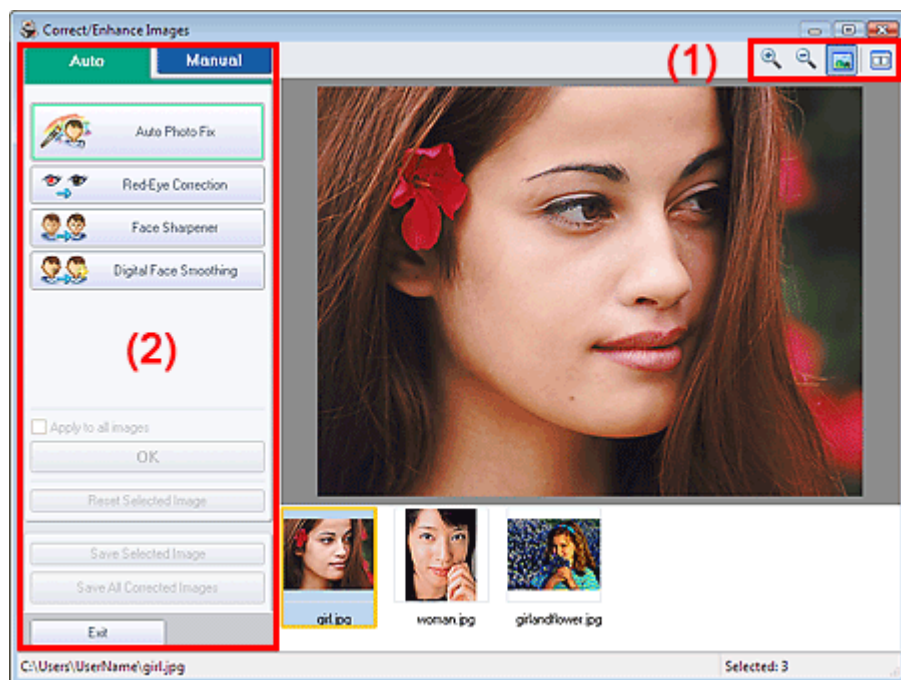

### (1)Toolbar

#### Toolbar

##### (Zoom In/Zoom Out)

Displays the enlarged or reduced preview of the page.

##### (Full Screen)

Displays the entire image in Preview.

##### (Compare)

Displays the Compare Images window. You can compare the images before and after the correction side by side.

The image before the correction/enhancement is displayed on the left, and the image after the correction/enhancement is displayed on the right.

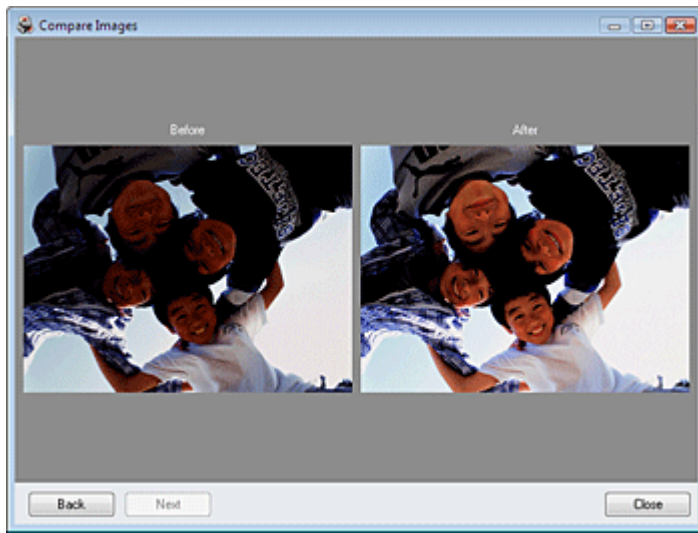

## (2)Task Area

Available tasks and settings may vary between the Auto and Manual tabs. Click Auto or Manual to display the corresponding tab.

### Auto Tab

Select to correct automatically.

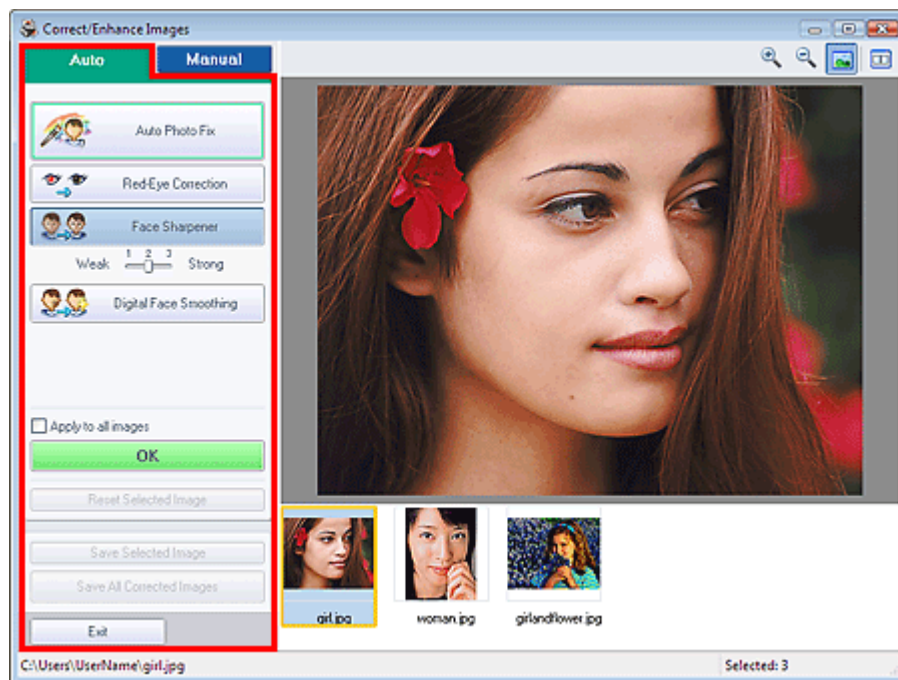

### Auto Photo Fix

Applies automatic corrections suitable for photos.

#### Important

- The Auto Photo Fix function is not available for Photo Print. Photo Print allows you to automatically apply suitable corrections to all photos when printing. Select this option in Image on the Advanced tab of the Preferences dialog box. To display the Preferences dialog box, click  (Settings) in the Layout/Print screen or select Preferences... from the File menu.

### Red-Eye Correction

Corrects red eyes.

#### Note

- For Photo Print, you can also correct red eyes by selecting Enable Auto Photo Fix in Color correction for printing on the Advanced tab of the Preferences dialog box and selecting the Enable Red-Eye Correction checkbox.

**Face Sharpener**

Sharpens out-of-focus faces.

You can adjust the effect level using the slider.

**Digital Face Smoothing**

Enhances skin beautifully by removing blemishes and wrinkles.

You can adjust the effect level using the slider.

**Apply to all images**

Automatically corrects all the images displayed in the list.

**OK**

Applies the selected effect to the selected image or all images.

**Reset Selected Image**

Cancels all corrections and enhancements applied to the selected image.

**Save Selected Image**

Saves the selected image.

**Save All Corrected Images**

Saves all the images displayed in the list.

**Exit**

Click to close the Correct/Enhance Images window.

**Manual Tab**

Select to correct manually.

Use Adjust to adjust brightness and contrast, or to sharpen the entire image.

Use Correct/Enhance to correct/enhance specific areas.

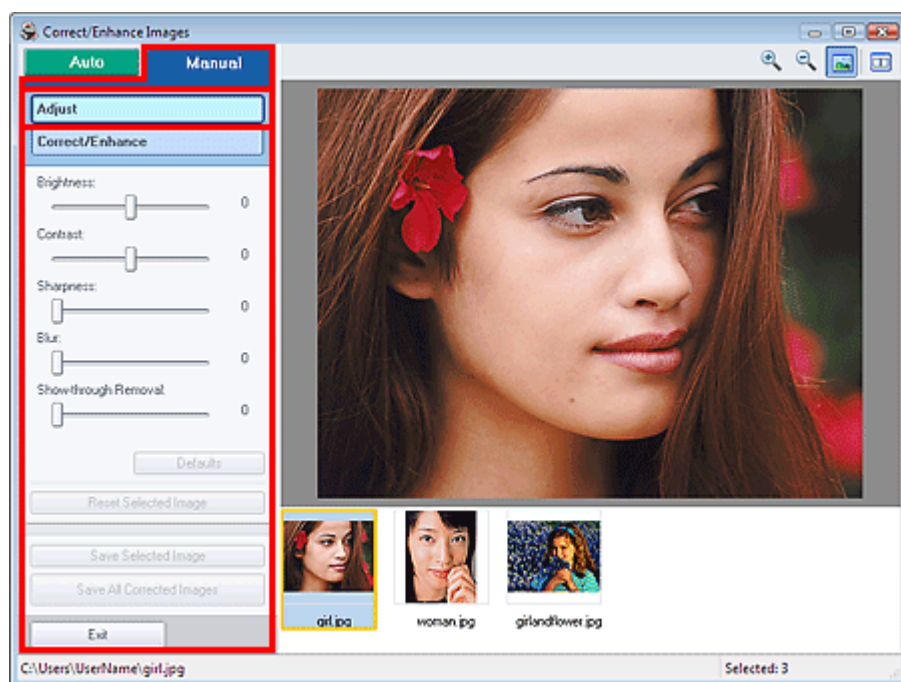
**Adjust****Brightness**

Adjusts the overall image brightness.

Move the slider to the left to darken and right to brighten the image.

**Contrast**

Adjusts the contrast of the image. Adjust the contrast when the image is flat due to lack of contrast.

Move the slider to the left to decrease and right to increase the contrast of the image.

**Sharpness**

Emphasizes the outline of the subjects to sharpen the image. Adjust the sharpness when the photo is out of focus or text is blurred.

Move the slider to the right to sharpen the image.

**Blur**

Blurs the outline of the subjects to soften the image.  
Move the slider to the right to soften the image.

**Show-through Removal**

Removes show-through of text from the reverse side or removes the base color. Adjust the show-through level to prevent text on the reverse side of thin document or the base color of the document from appearing on the image.

Move the slider to the right to increase the show-through removal effect.

**Defaults**

Resets all adjustments (brightness, contrast, sharpness, blur, and show-through removal).

**Reset Selected Image**

Cancels all adjustments applied to the selected image.

**Save Selected Image**

Saves the selected image.

**Save All Corrected Images**

Saves all the images displayed in the list.

**Exit**

Click to close the Correct/Enhance Images window.

**Correct/Enhance****Red-Eye Correction**

Corrects red eyes.

You can specify the area you want to apply the effect to. You can adjust the effect level using the slider.

**Note**

- For Photo Print, red eyes are automatically corrected when Enable Auto Photo Fix is selected in Color correction for printing on the Advanced tab of the Preferences dialog box and the Enable Red-Eye Correction checkbox is selected. To disable the automatic correction, deselect the checkbox.

**Face Brightener**

Corrects the entire image so that the selected facial area is brightened.

You can adjust the effect level using the slider.

**Face Sharpener**

Sharpens out-of-focus faces.

You can specify the area you want to apply the effect to. You can adjust the effect level using the slider.

## **Digital Face Smoothing**

Enhances skin beautifully by removing blemishes and wrinkles.

You can specify the area you want to apply the effect to. You can adjust the effect level using the slider.

## **Blemish Remover**

Removes moles.

You can specify the area you want to apply the effect to.

## **Undo**

Cancels the latest correction/enhancement.

## **OK**

Applies the selected effect to the specified area.

## **Reset Selected Image**

Cancels all corrections and enhancements applied to the selected image.

## **Save Selected Image**

Saves the selected image.

## **Save All Corrected Images**

Saves all the images displayed in the list.

## **Exit**

Click to close the Correct/Enhance Images window.

## Advanced Guide

[Advanced Guide](#) > [Printing from a Computer](#) > [Printing with the Bundled Application Software](#) > [Questions and Answers](#)

### Questions and Answers

- ➔ [How Can I Move \(or Copy\) the Saved File?](#)
- ➔ [Which Side of the Displayed Image Does the Printing Start from?](#)
- ➔ [How Do I Print with Even Margins?](#)
- ➔ [What Is "C1" or "C4"?](#)

[Page top](#)↑

## Advanced Guide

Advanced Guide > Printing from a Computer > Printing with the Bundled Application Software > Questions and Answers  
> How Can I Move (or Copy) the Saved File?

### How Can I Move (or Copy) the Saved File?

If you want to move (or copy) a file created and saved with Easy-PhotoPrint EX from one folder to another, you need to move (or copy) the folder that was automatically created when originally saving that file as well.

For example, when you save a file named "MyAlbum.e1," a folder named "MyAlbum.e1.Data" is automatically created in the same folder that contains the "MyAlbum.e1" file. If you want to move (or copy) the "MyAlbum.e1" file to another folder, move (or copy) the "MyAlbum.e1.Data" folder as well.

The "MyAlbum.e1.Data" folder contains the photos used in the album.

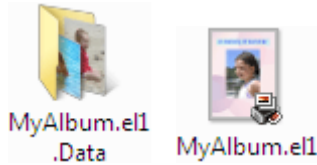

#### Note

- The icons may vary depending on the items.

#### Important

- Do not change the Data folder name; otherwise you will not be able to display the photos you edited with Easy-PhotoPrint EX.

## Advanced Guide

Advanced Guide > Printing from a Computer > Printing with the Bundled Application Software > Questions and Answers > Which Side of the Displayed Image Does the Printing Start from?

### Which Side of the Displayed Image Does the Printing Start from?

As shown below, printing starts from the left side of the image displayed in the Layout/Print screen.



Outputs the paper in the direction as the arrow indicates.

See your printer manual for details on how to load paper (to print on the front/back, etc.).

[Page top](#)



## Advanced Guide

[Advanced Guide](#) > [Printing from a Computer](#) > [Printing with the Bundled Application Software](#) > [Questions and Answers](#)  
> [How Do I Print with Even Margins?](#)

---

### How Do I Print with Even Margins?

When you print on a bordered layout, the margins on the left and right or the top and bottom may become wider than the other, depending on the image and printer.

To always print with even margins, select the Always crop images when selecting a layout with margins checkbox on the Advanced tab of the Preferences dialog box.

To display the Preferences dialog box, click  (Settings) in the Layout/Print screen or select Preferences... from the File menu.

Crop the photo to apply even margins individually.

➔ [Cropping Photos \(Photo Print\)](#)



#### Note

- The following setting is available for Photo Print only.

## Advanced Guide

Advanced Guide > Printing from a Computer > Printing with the Bundled Application Software > Questions and Answers  
> What Is "C1" or "C4"?

### What Is "C1" or "C4"?

When an album is printed, labels such as "C1" and "C4" are printed as page numbers.

The "C1" and "C4" represent the front cover and back cover, respectively.

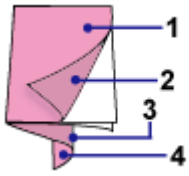

C1: Front cover

C2: Inside the front cover

C3: Inside the back cover

C4: Back cover

[Page top](#)↑

## Advanced Guide

Advanced Guide > Printing from a Computer > Printing with the Bundled Application Software > Appendix 1: Easy-PhotoPrint EX Settings

### Appendix 1: Easy-PhotoPrint EX Settings

- ➔ Printing Vivid Photos
- ➔ Reducing Photo Noise
- ➔ Cropping Photos (Photo Print)
- ➔ Printing Dates on Photos (Photo Print)
- ➔ Printing Multiple Photos on One Page
- ➔ Printing an Index
- ➔ Printing ID Photos (ID Photo Print)
- ➔ Printing Photo Information
- ➔ Saving Photos
- ➔ Opening Saved Files
- ➔ Changing Layout
- ➔ Changing Background
- ➔ Adding Photos
- ➔ Swapping Positions of Photos
- ➔ Replacing Photos
- ➔ Changing Position, Angle and Size of Photos
- ➔ Cropping Photos
- ➔ Framing Photos
- ➔ Printing Dates on Photos
- ➔ Attaching Comments to Photos
- ➔ Adding Text to Photos
- ➔ Saving
- ➔ Setting Holidays
- ➔ Setting Calendar Display

[Page top](#)↑

## Advanced Guide

Advanced Guide > Printing from a Computer > Printing with the Bundled Application Software > Appendix 1: Easy-PhotoPrint EX Settings > Printing Vivid Photos

## Printing Vivid Photos

Select the Vivid Photo checkbox in the Select Paper screen to boost the colors in a photo before printing.

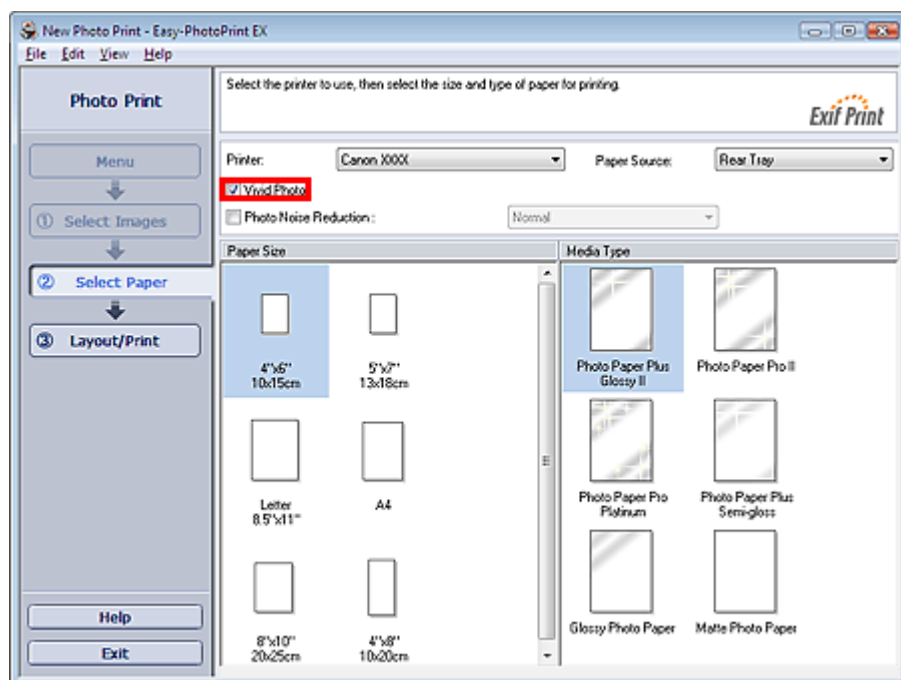

### Important

- This function is available only with a printer that supports Vivid Photo.
- This function is not available when Enable ICC Profile is selected on the Advanced tab of the Preferences dialog box.

### Note

- Even if you select the Vivid Photo checkbox, this effect applies only to the print result. The original image or preview image will not be affected.

## Advanced Guide

Advanced Guide > Printing from a Computer > Printing with the Bundled Application Software > Appendix 1: Easy-PhotoPrint EX Settings > Reducing Photo Noise

## Reducing Photo Noise

When a photo is taken in a dark location such as night scene using digital camera, noise may appear in the image.

Select the Photo Noise Reduction checkbox in the Select Paper screen to reduce noise in the image and make the printed photos more vivid.

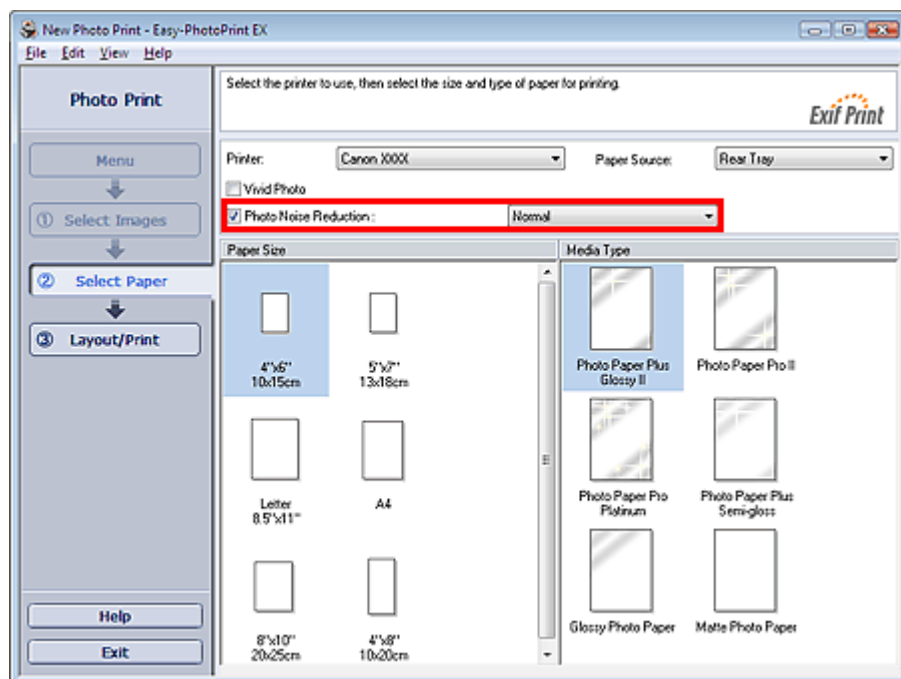

### Important

- This function is not available when Enable ICC Profile is selected on the Advanced tab of the Preferences dialog box.

### Note

- When the noise is severe, change Normal to Strong.
- The noise reduction effect applies only to the print result. The original image or preview image will not be affected.

## Advanced Guide

Advanced Guide > Printing from a Computer > Printing with the Bundled Application Software > Appendix 1: Easy-PhotoPrint EX Settings > Cropping Photos (Photo Print)

### Cropping Photos (Photo Print)

Cropping a photo is the act of removing the unnecessary portions of the photo by selecting the necessary portions.

Click  (Crop Image) in the Layout/Print screen.

Move the white frame to the portion to print and click OK.

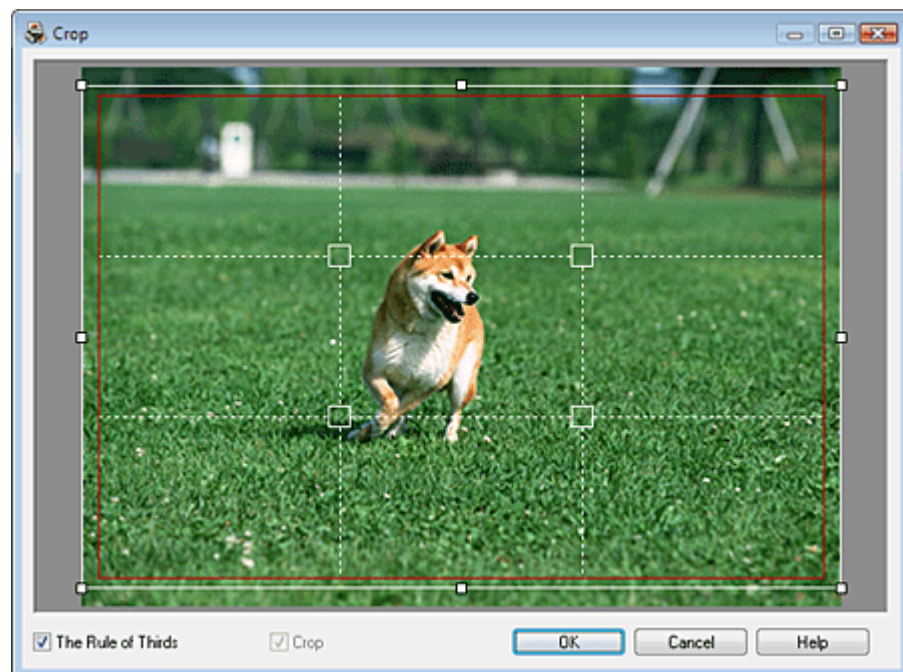

#### Note

- To move the cropping area, place the cursor within the white frame and drag it. Drag the white lines to enlarge/reduce the cropping area.
- Select the The Rule of Thirds checkbox to display white broken lines. To create a balanced composition, drag any of the intersecting points (white squares) or white broken lines over the main subject of the photo.

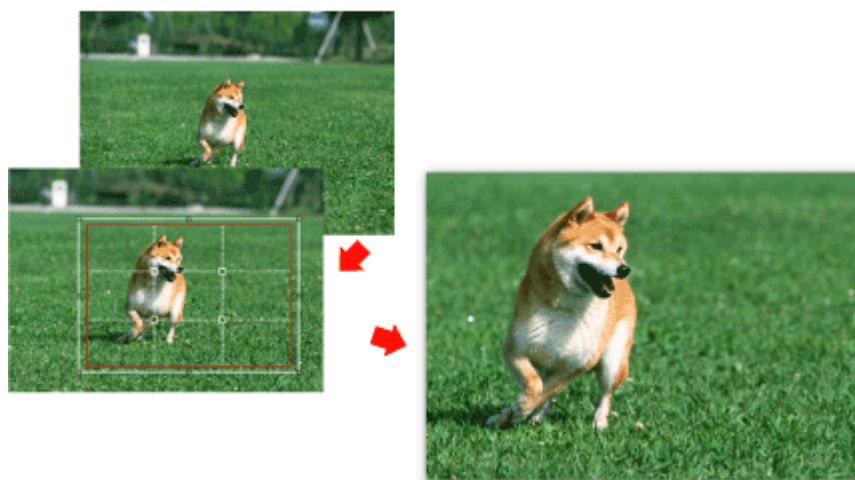

- The cropping effect applies only to the print result. The original image will not be cropped.
- See Help for details on the Crop window.

## Advanced Guide

Advanced Guide > Printing from a Computer > Printing with the Bundled Application Software > Appendix 1: Easy-PhotoPrint EX Settings > Printing Dates on Photos (Photo Print)

### Printing Dates on Photos (Photo Print)

To print the date the photo was taken on the photo, click  (Date Settings) in the Layout/Print screen, then select the Print date checkbox in the Date Settings dialog box.

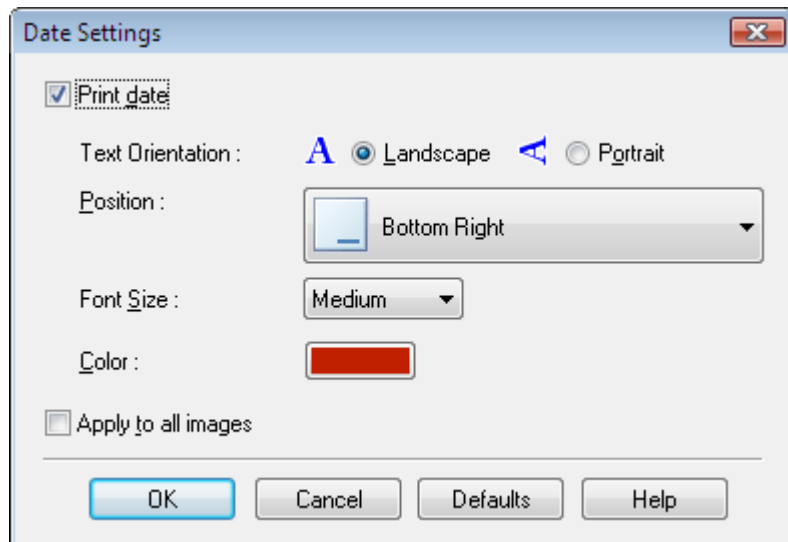

#### Note

- The date is displayed in the short date format (mm/dd/yyyy, etc.) specified in your operating system.
- In the Date Settings dialog box, you can change the orientation, position, size and color of the date according to the orientation and background of the photo. See Help for details.

## Advanced Guide

Advanced Guide > Printing from a Computer > Printing with the Bundled Application Software > Appendix 1: Easy-PhotoPrint EX Settings > Printing Multiple Photos on One Page

### Printing Multiple Photos on One Page

You can print multiple photos on one page by selecting a multiple-photo layout in the Layout/Print screen.



#### Note

- See the following section for details on how to select photos.  
 ➔ [Selecting a Photo](#)
- The available number of photos and layout may vary depending on the media type.
- Photos are arranged in the following order.

Example: Borderless (x4)

1	3
2	4

- You can change the printing order in Printing Order on the Print tab of the Preferences dialog box. You can select the printing order from By Date, By Name and By Selection.

To display the Preferences dialog box, click  (Settings) or select Preferences... from the File menu.



## Advanced Guide

Advanced Guide > Printing from a Computer > Printing with the Bundled Application Software > Appendix 1: Easy-PhotoPrint EX Settings > Printing an Index

## Printing an Index

You can print an index of selected photos. An index print shows the thumbnails of the photos in one page. It is convenient for managing your photos.

To print an index, select Index from the layouts in the Layout/Print screen.

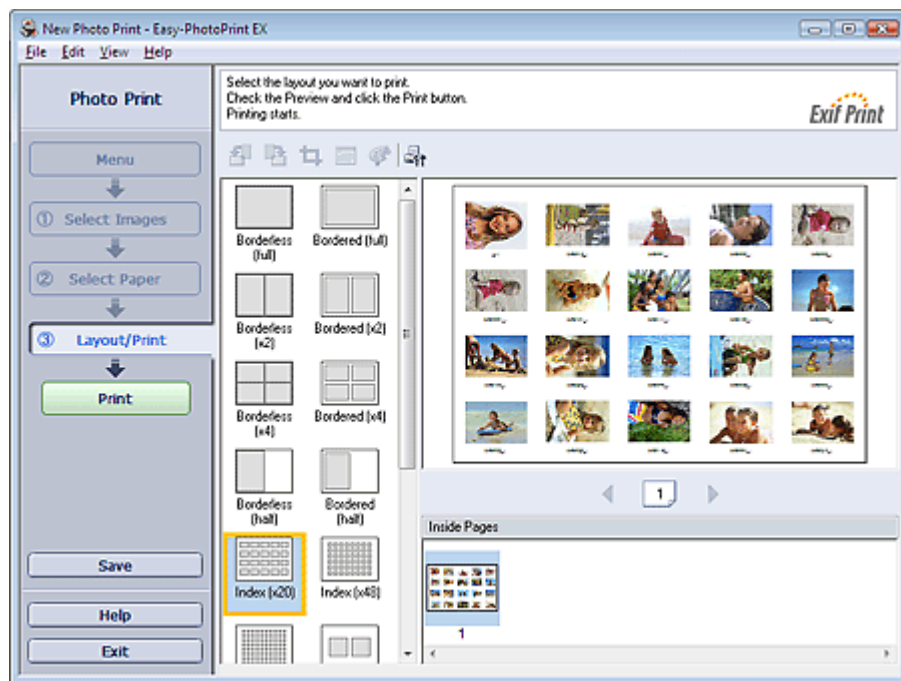

### Note

- See the following section for details on how to select photos.  
➔ [Selecting a Photo](#)
- Index print will be disabled if you select any of the following paper sizes.
  - Credit Card
  - Fine Art A4
  - Fine Art A3
  - Fine Art A3+
  - Fine Art Letter
- Up to 80 thumbnails can be printed on one page.
- Photos are arranged in the following order.  
Example: Index (x20)

1	2	3	4	5
6	7	8	9	10
11	12	13	14	15
16	17	18	19	20

- You can change the printing order in Printing Order on the Print tab of the Preferences dialog box. You can select the printing order from By Date, By Name, and By Selection.

To display the Preferences dialog box, click  (Settings) or select Preferences... from the File menu.

## Advanced Guide

Advanced Guide > Printing from a Computer > Printing with the Bundled Application Software > Appendix 1: Easy-PhotoPrint EX Settings > Printing ID Photos (ID Photo Print)

## Printing ID Photos (ID Photo Print)

You can print a variety of ID photos.

### Important

- The photo may not qualify as an official ID photo depending on its use. For details, contact the party to whom you will be submitting the photo.

To print ID photos, select 4"x6" 10x15cm for Paper Size in the Select Paper screen, and select a layout of the ID photo from the layouts in the Layout/Print screen.

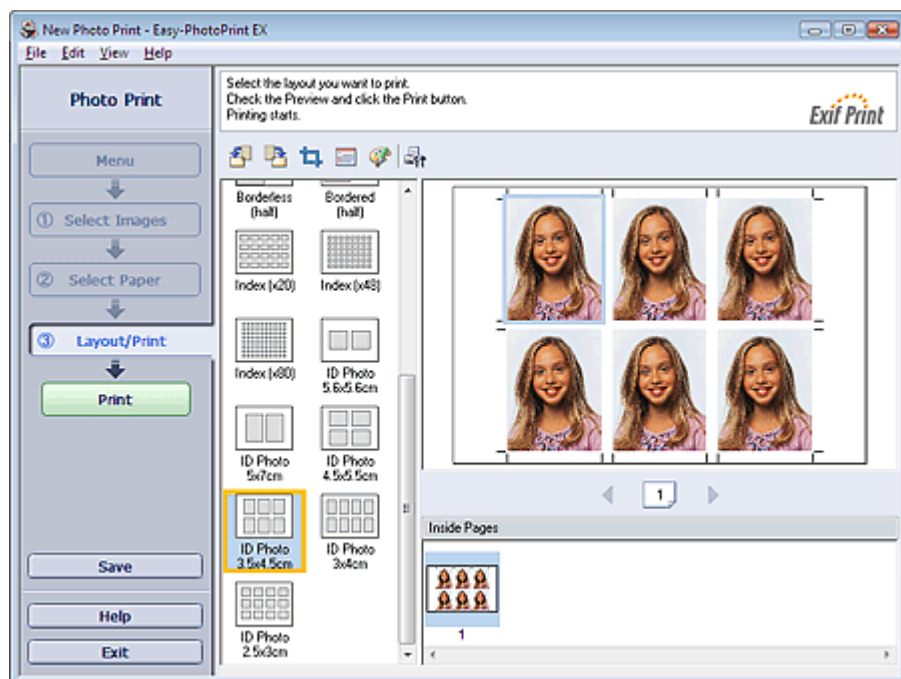

### Note

- See the following section for details on how to select photos.

#### ➔ Selecting a Photo

- Photos are arranged in the following order.

Example: ID Photo 3.5x4.5cm



- You can change the printing order in Printing Order on the Print tab of the Preferences dialog box. You can select the printing order from By Date, By Name, and By Selection.

To display the Preferences dialog box, click  (Settings) or select Preferences... from the File menu.

## Advanced Guide

Advanced Guide > Printing from a Computer > Printing with the Bundled Application Software > Appendix 1: Easy-PhotoPrint EX Settings > Printing Photo Information

## Printing Photo Information

Select Captured Info from the layouts in the Layout/Print screen to print the photo and the Exif information side by side.

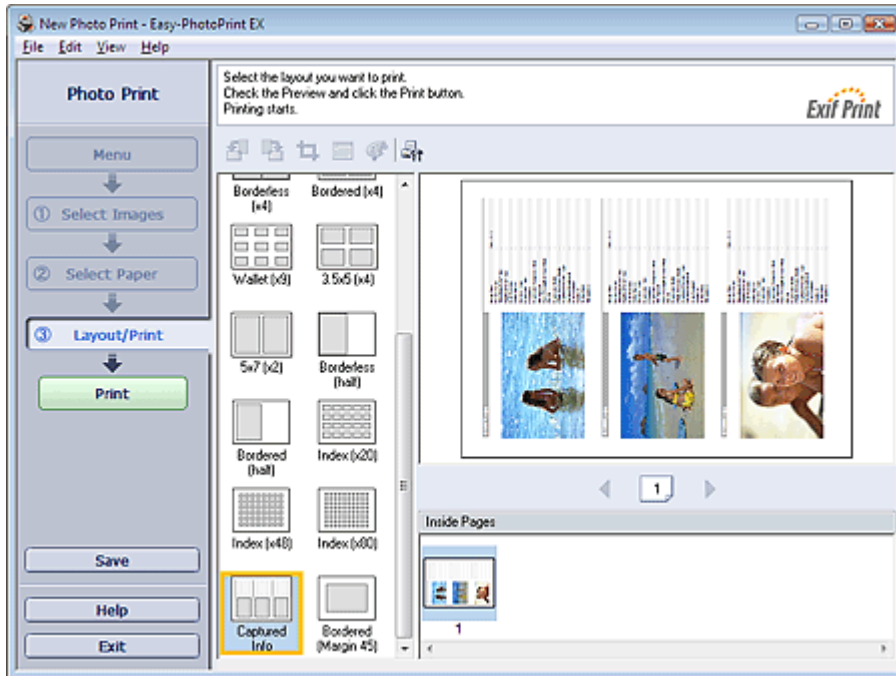

### Note

- See the following section for details on how to select photos.
  - [Selecting a Photo](#)
- This function is available only on paper sizes Letter 8.5"x11" and A4.

## Advanced Guide

Advanced Guide > Printing from a Computer > Printing with the Bundled Application Software > Appendix 1: Easy-PhotoPrint EX Settings > Saving Photos

## Saving Photos

You can save edited photos. The information of cropping and layout can be saved.

Click Save in the Layout/Print screen.

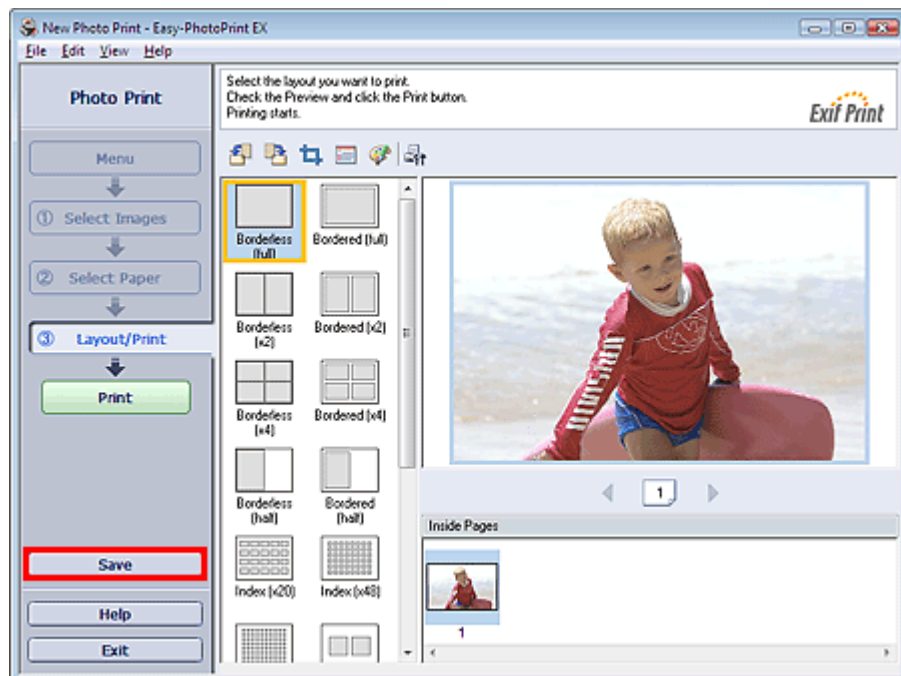

When the Save As dialog box appears, specify the save location and file name, then click Save.

### Important

- If you edit a saved file and save it again, the file will be overwritten.  
To save a file again with a new name or to a different location, select Save As... from the File menu and save.

### Note

- Save will not be displayed in the Select Images or Select Paper screen.

## Advanced Guide

Advanced Guide > Printing from a Computer > Printing with the Bundled Application Software > Appendix 1: Easy-PhotoPrint EX Settings > Opening Saved Files

## Opening Saved Files

You can open files created with Easy-PhotoPrint EX.

### 1. Click Library from Menu.

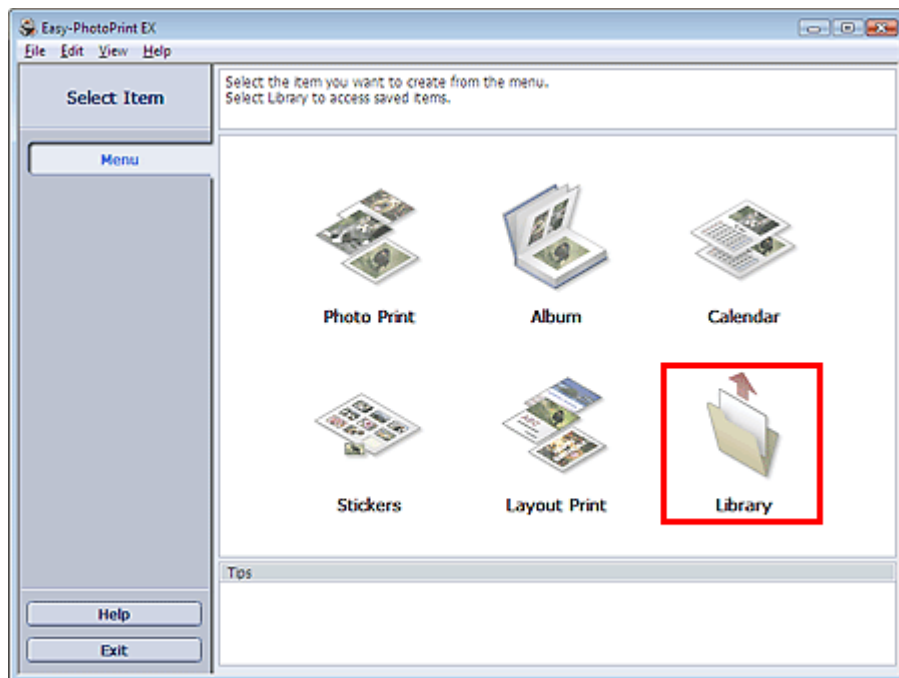

The Open dialog box appears.

You can check files created and saved with Easy-PhotoPrint EX by icon view (only for Windows Vista) or thumbnail view.

#### Important

- When using 64bit Edition of Windows Vista or Windows XP, the contents of files cannot be displayed on Explorer.

### 2. Select the file you want to open and click Open.

The Edit or Select Paper screen appears.

#### Note

- Easy-PhotoPrint EX supports the following file formats (extensions).
  - Easy-PhotoPrint EX Photo Print file (.el6)
  - Easy-PhotoPrint EX Album file (.el1)
  - Easy-PhotoPrint EX Stickers file (.el2)
  - Easy-PhotoPrint EX Calendar file (.el4)
  - Easy-PhotoPrint EX Layout file (.el5)

### 3. Edit the file if necessary.

#### Note

- See the following sections for details on the editing procedures.
  - ➔ [Editing Album](#)
  - ➔ [Editing Calendar](#)
  - ➔ [Editing Stickers](#)
  - ➔ [Editing Layout Print](#)

#### Note

- You can open files created with Easy-PhotoPrint EX with the following methods, besides from

Library in Menu.

- Double-click or click the file.
  - From the File menu, click Open..., then select the file you want to edit.
  - You can also open a recently used file by clicking the file name shown in the File menu.
- 

[Page top](#)↑

## Advanced Guide

Advanced Guide > Printing from a Computer > Printing with the Bundled Application Software > Appendix 1: Easy-PhotoPrint EX Settings > Changing Layout

## Changing Layout

You can change the layout of each page separately.

Select the page you want to change the layout of in the Edit screen, then click  (Change Layout).  
Select the layout you want to use in the Change Layout dialog box and click OK.

### Album

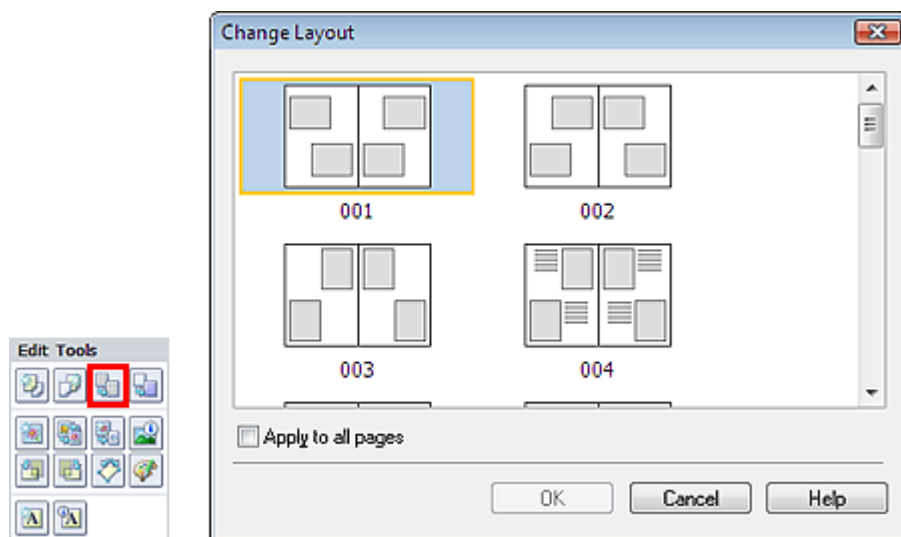

### Important

- The album layouts that can be selected may vary depending on the Paper Size, Orientation, or the type of page selected (front cover, inside pages or back cover).
- If the new layout has a different number of frames per page from the current layout, the following will happen:
 

If the number of layout frames is increased	: Images will move from the subsequent pages to fill all the frames in the new layout.
If the number of layout frames is decreased	: Pages with the new layout will be added until all the images on the pages with the current layout can be fitted.
- If you change the selected layout for the front or back cover to one that has fewer layout frames, any image that does not fit in the new layout will be deleted, starting with the last image that was added to the former layout page.

### Note

- Select the Apply to all pages checkbox to change the layouts of all pages to the one you newly selected.

### Calendar

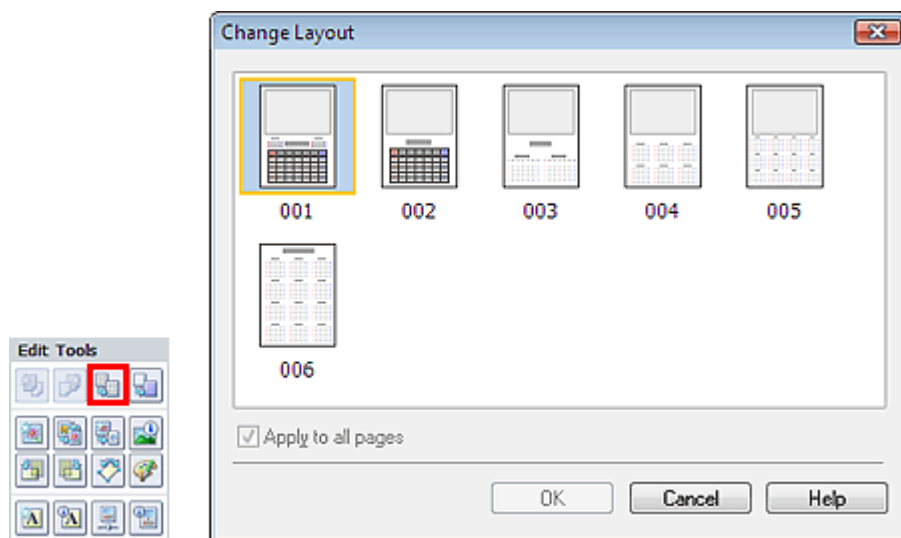

### Important

- The layouts that can be selected may vary depending on the Paper Size and Orientation.
- The layouts of all pages are changed to the selected layout.
- All images that do not fit in the new layout will be collected on one page.

### Layout Print

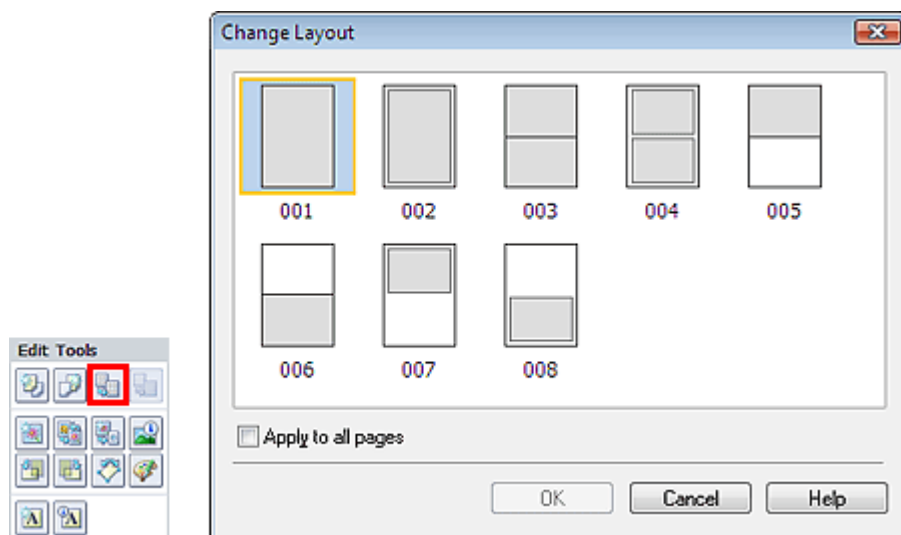

### Important

- The layouts that can be selected may vary depending on the Paper Size and Orientation.
- If the new layout has a different number of frames per page from the current layout, the following will happen:
 

If the number of layout frames is increased	: Images will move from the subsequent pages to fill all the frames in the new layout.
If the number of layout frames is decreased	: Pages with the new layout will be added until all the images on the pages with the current layout can be fitted.

### Note

- Select the Apply to all pages checkbox to change the layouts of all pages to the one you newly selected.



## Advanced Guide

Advanced Guide > Printing from a Computer > Printing with the Bundled Application Software > Appendix 1: Easy-PhotoPrint EX Settings > Changing Background

# Changing Background

You can change the background of each page.

### Important

- You cannot change the background of the Photo Print, Stickers, and Layout Print.

Select the page you want to change the background of in the Edit screen, then click  (Change Background).

### Note

- The screens for Album printing are used as examples in the following descriptions. The screens may vary depending on what you create.

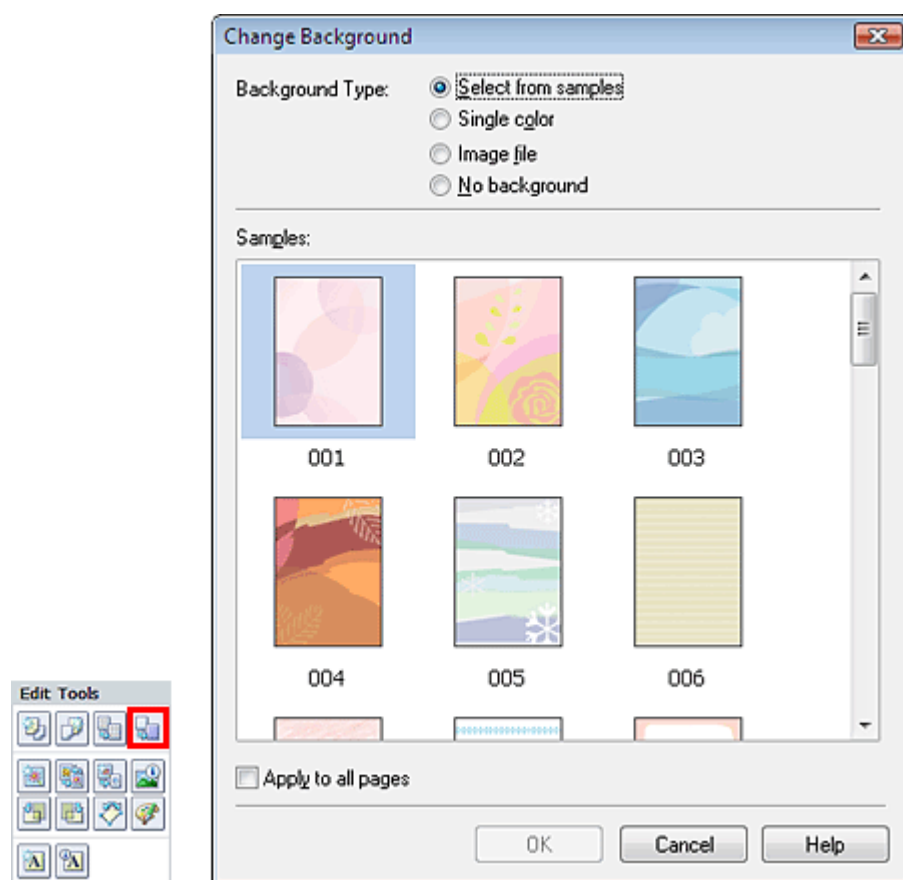

Select the type of background you want to use in the Change Background dialog box.

### When **Select from samples** is Selected

Select the image you want to use from Samples and click OK.

### Note

- Select from samples will be displayed only if Album has been selected.

### When **Single color** is Selected

Select the color you want to use from Standard color or Custom color and click OK.

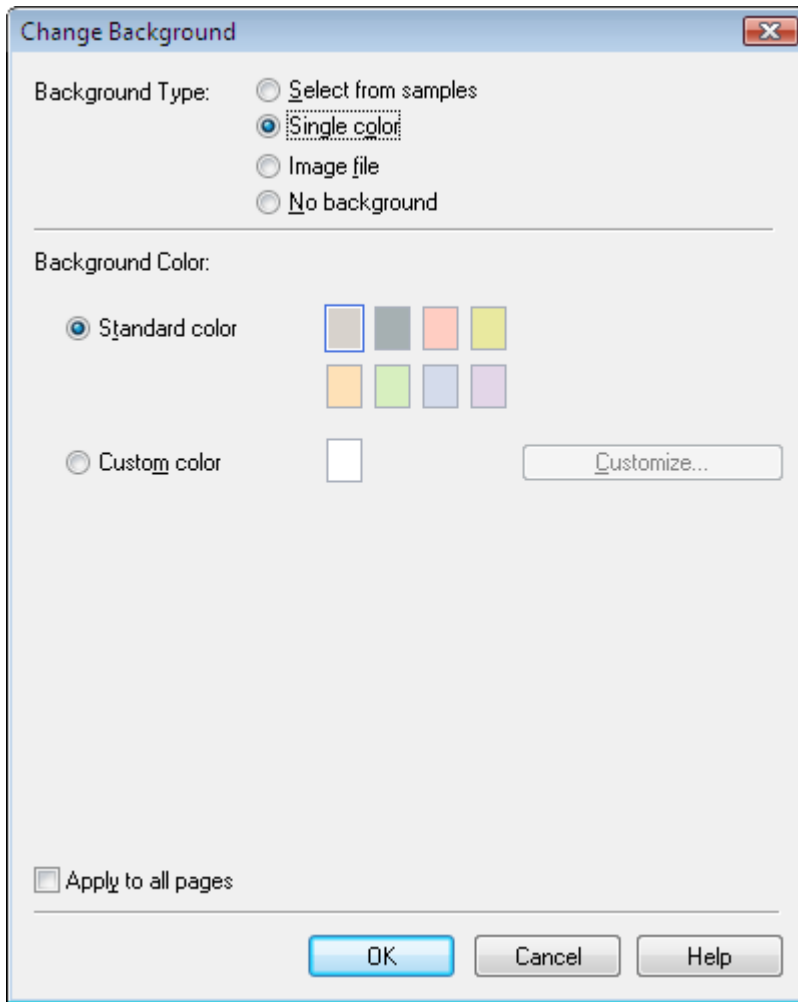

### When Image file is Selected

Set Image File Path and Image Layout, then click OK.

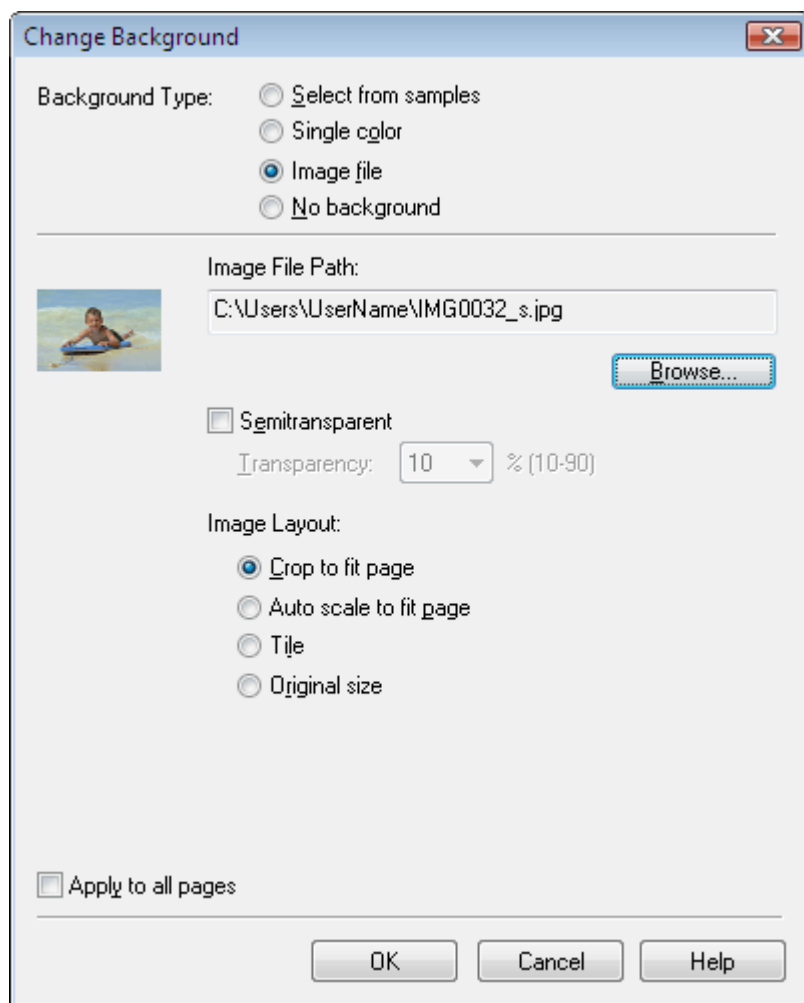
**Note**

- See Help for details on how to set the background in the Change Background dialog box.

## Advanced Guide

Advanced Guide > Printing from a Computer > Printing with the Bundled Application Software > Appendix 1: Easy-PhotoPrint EX Settings > Adding Photos

## Adding Photos

You can add images to pages.

Select the page you want to add photos in the Edit screen, then click  (Add Image).

### Note

- The screens for Album printing are used as examples in the following descriptions. The screens may vary depending on what you create.

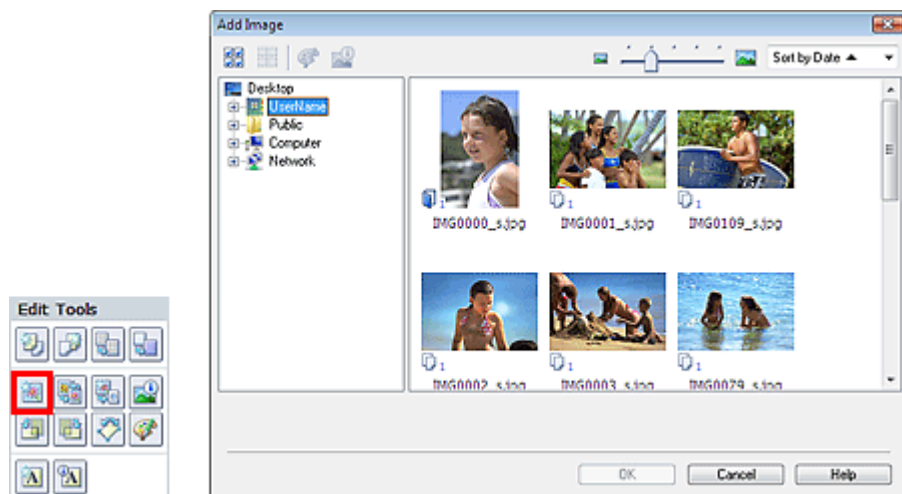

Select the folder containing the image you want to add from the folder tree area on the left of the Add Image dialog box, and select the image you want to add from the thumbnail window on the right.

### Note

- Click an image to select it (background turns blue) or deselect it (background turns white). You can also select multiple images.

Select an option for Add to and click OK.

### Important

- You can add up to 20 images at one time to a single page.
- Up to 99 of the same images can be added to all pages combined.
- You cannot add two or more of the same image at one time. In that case, add it one at a time.
- If you increase the number of pages to add images, you cannot add images beyond page 400.

### Note

- In the Add Image dialog box, you can select all images at one time or change the display size and order of the thumbnails. See Help for details.

## Advanced Guide

Advanced Guide > Printing from a Computer > Printing with the Bundled Application Software > Appendix 1: Easy-PhotoPrint EX Settings > Swapping Positions of Photos

# Swapping Positions of Photos

You can swap the positions of images.

Click  (Swap Image Positions) in the Edit screen.

### Note

- The screens for Album printing are used as examples in the following descriptions. The screens may vary depending on what you create.



Select the target and source images you want to swap, then click Swap.  
When you finish swapping all images you want to swap, click Back to Edit.

## Advanced Guide

Advanced Guide > Printing from a Computer > Printing with the Bundled Application Software > Appendix 1: Easy-PhotoPrint EX Settings > Replacing Photos

## Replacing Photos

You can replace an image with another image.

Select the image you want to replace in the Edit screen, then click  (Replace Selected Image).

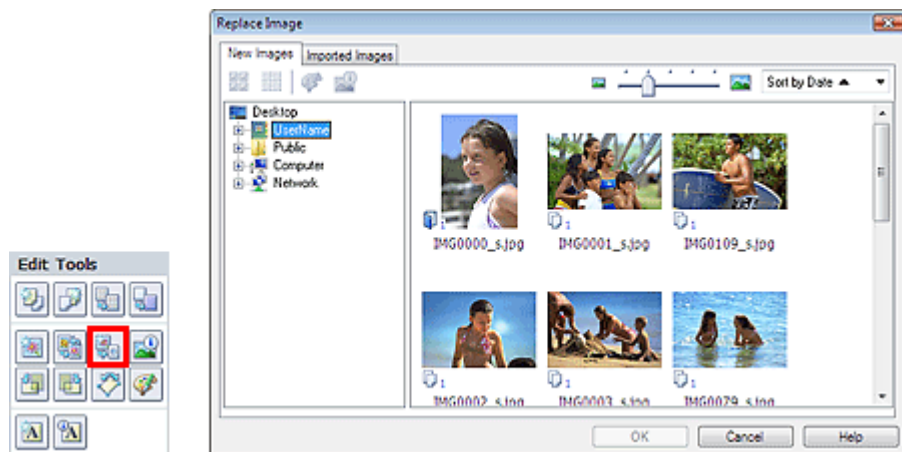

Select the folder containing the image you want to replace with from the folder tree area on the left of the Replace Image dialog box.

Select the image you want to replace with from the thumbnail window on the right of the screen and click OK.

If you want to select from the images already imported, click the Imported Images tab and select the image you want to replace with from the thumbnail window and click OK.

### Important

- You cannot select multiple images in the Replace Image dialog box.

### Note

- If you select multiple images in the Edit screen and use the replacement function, all the images selected in the Edit screen will be replaced with the image selected in the Replace Image dialog box.
- When images are replaced, the following settings of the old image are inherited to the new image.
  - Position
  - Size
  - Frame
  - Position and size of the date
 The cropping information and image orientation are not inherited.
- In the Replace Image dialog box, you can change the display size and order of the thumbnails. See Help for details.

## Advanced Guide

Advanced Guide > Printing from a Computer > Printing with the Bundled Application Software > Appendix 1: Easy-PhotoPrint EX Settings > Changing Position, Angle and Size of Photos

### Changing Position, Angle and Size of Photos

You can adjust the position, angle and size of images.

Select the image of which you want to change the position or size in the Edit screen and click  (Edit Image) or double-click the image.

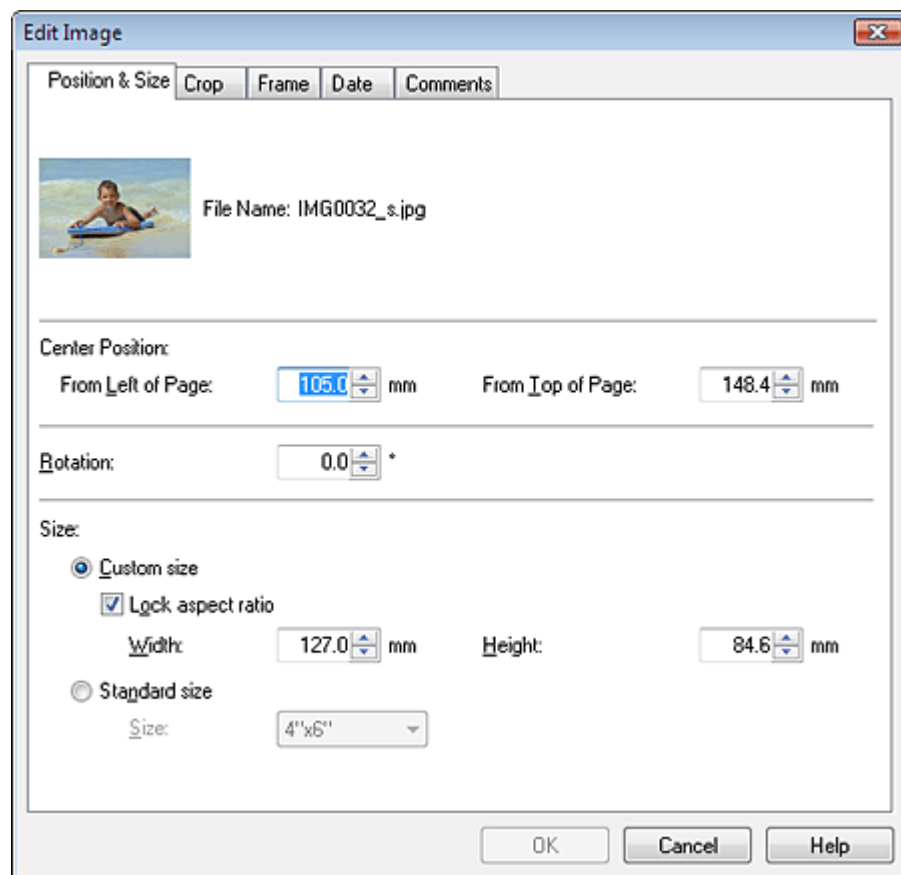

Set the Center Position, Rotation and Size, then click OK.

#### Note

- You can also change the position and size of an image by dragging it in the Edit screen.
- Select an image in the Edit screen, then click  (Free Rotate) and drag a corner of the image to rotate it.
- See Help for details on the position and size of images.

## Advanced Guide

Advanced Guide > Printing from a Computer > Printing with the Bundled Application Software > Appendix 1: Easy-PhotoPrint EX Settings > Cropping Photos

# Cropping Photos

Cropping an image is the act of removing the unnecessary portions of the image by selecting the necessary portions.

Select the image you want to crop in the Edit screen and click  (Edit Image) or double-click the image.

Click the Crop tab in the Edit Image dialog box.

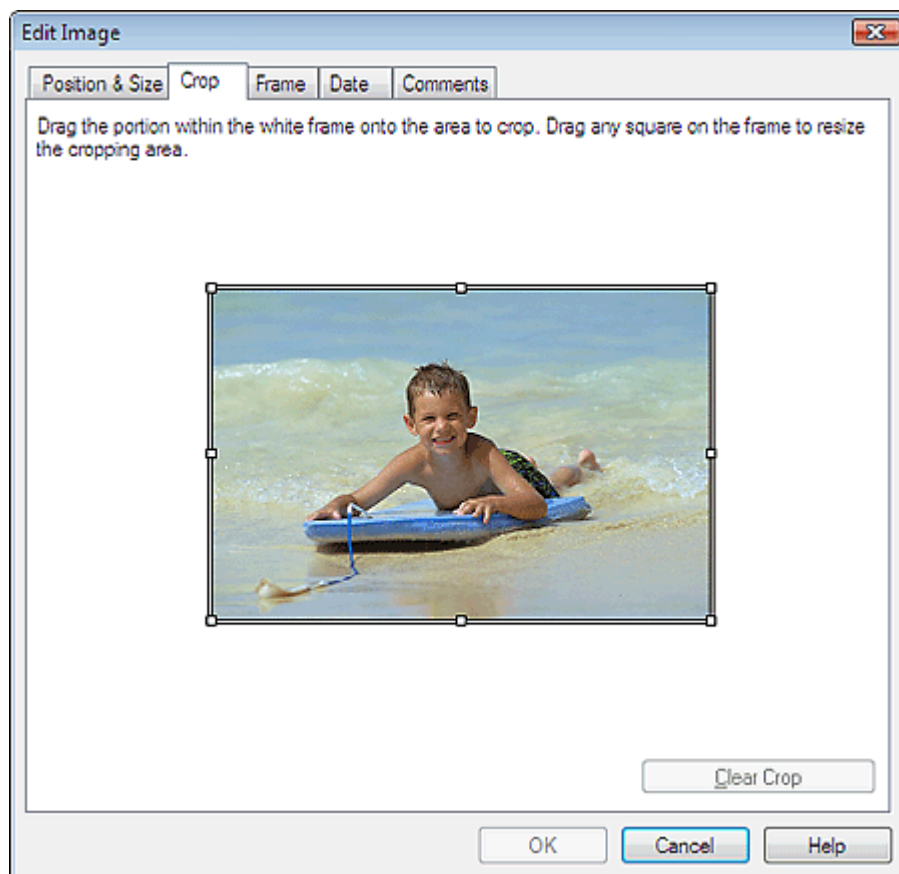

Drag the white squares on the image to change the area to be cropped and click OK.

### Note

- See Help for details on cropping.



## Advanced Guide

Advanced Guide > Printing from a Computer > Printing with the Bundled Application Software > Appendix 1: Easy-PhotoPrint EX Settings > Framing Photos

# Framing Photos

You can add frames to images.

### Important

- You cannot add frames to images in Photo Print, Stickers, and Layout Print.

Select the image you want to frame in the Edit screen and click  (Edit Image) or double-click the image.

Click the Frame tab in the Edit Image dialog box.

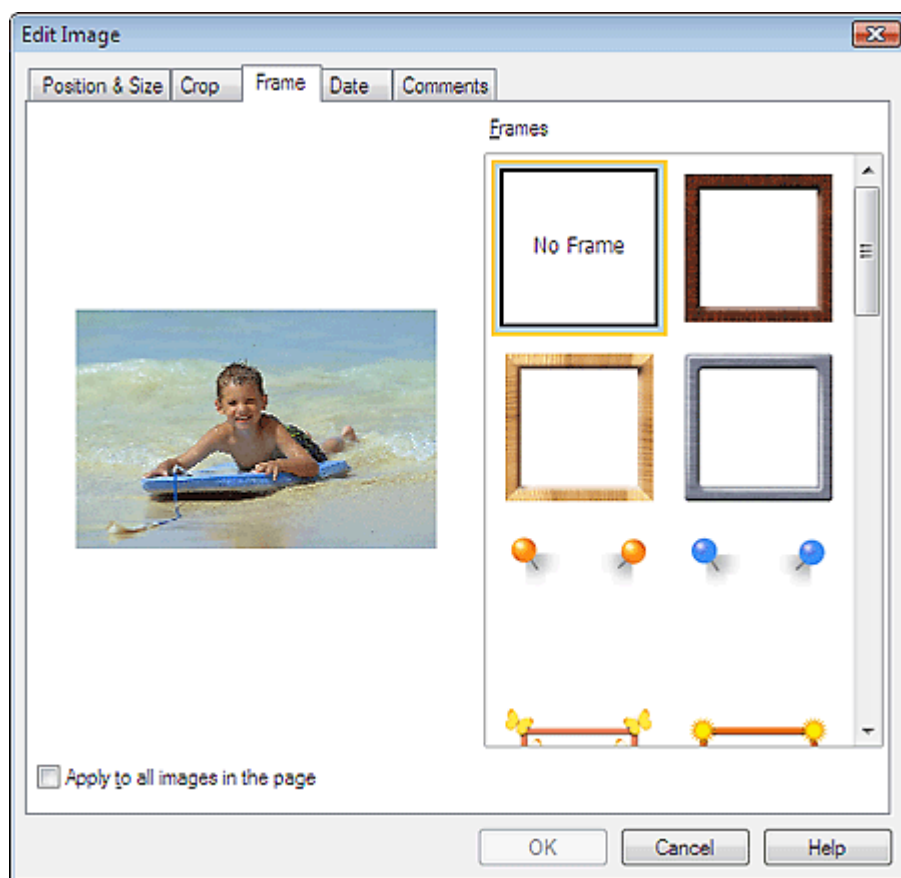

Select the frame you want to use from Frames and click OK.

### Important

- You cannot print dates on framed photos.

### Note

- Select the Apply to all images in the page checkbox to add the same frame to all the images on a selected page at one time.
- See Help for details on frames.

## Advanced Guide

Advanced Guide > Printing from a Computer > Printing with the Bundled Application Software > Appendix 1: Easy-PhotoPrint EX Settings > Printing Dates on Photos

# Printing Dates on Photos

You can print dates on images.

Select the image you want to print the date in the Edit screen and click  (Edit Image) or double-click the image.

Click the Date tab in the Edit Image dialog box.

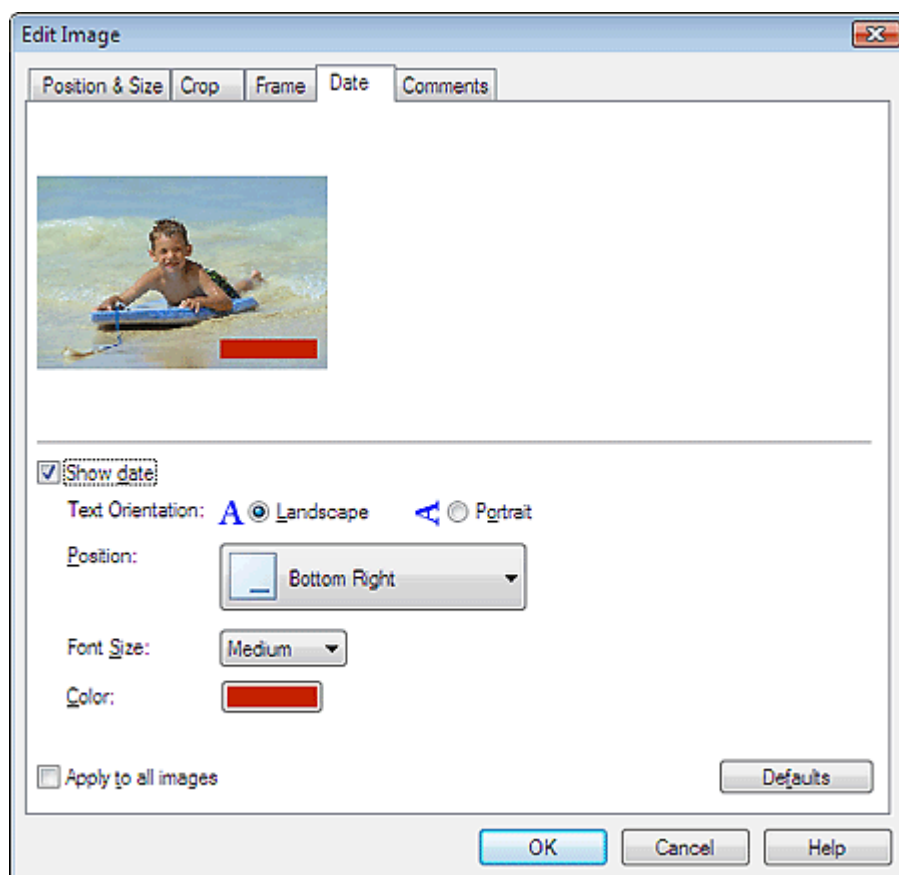

Select the Show date checkbox.

Set the Text Orientation, Position, Font Size and Color, then click OK.

### Important

- You cannot print dates on framed images.

### Note

- The date is displayed in the short date format (mm/dd/yyyy, etc.) specified in your operating system.
- See Help for details on setting dates.

## Advanced Guide

Advanced Guide > Printing from a Computer > Printing with the Bundled Application Software > Appendix 1: Easy-PhotoPrint EX Settings > Attaching Comments to Photos

### Attaching Comments to Photos

You can attach comments to images and display them in your album. The photo name, shooting date and comments are displayed (from top to bottom) in a comment box.



#### Important

- You cannot attach comments to Photo Print, Calendar, Stickers, and Layout Print.

Select the image you want to attach comments to in the Edit screen and click  (Edit Image) or double-click the image.

Click the Comments tab in the Edit Image dialog box.

Select the Show comment box checkbox.

Select the checkboxes of the items you want to display, and enter comments.

Set the size and color of font, and position, etc. of the comments, then click OK.

#### Note

- See Help for details on comments.



## Advanced Guide

Advanced Guide > Printing from a Computer > Printing with the Bundled Application Software > Appendix 1: Easy-PhotoPrint EX Settings > Adding Text to Photos

## Adding Text to Photos

You can add text to photos.

Click  (Add Text) in the Edit screen and drag the mouse over the area in which you want to add text.

### Note

- The screens for Album printing are used as examples in the following descriptions. The screens may vary depending on what you create.

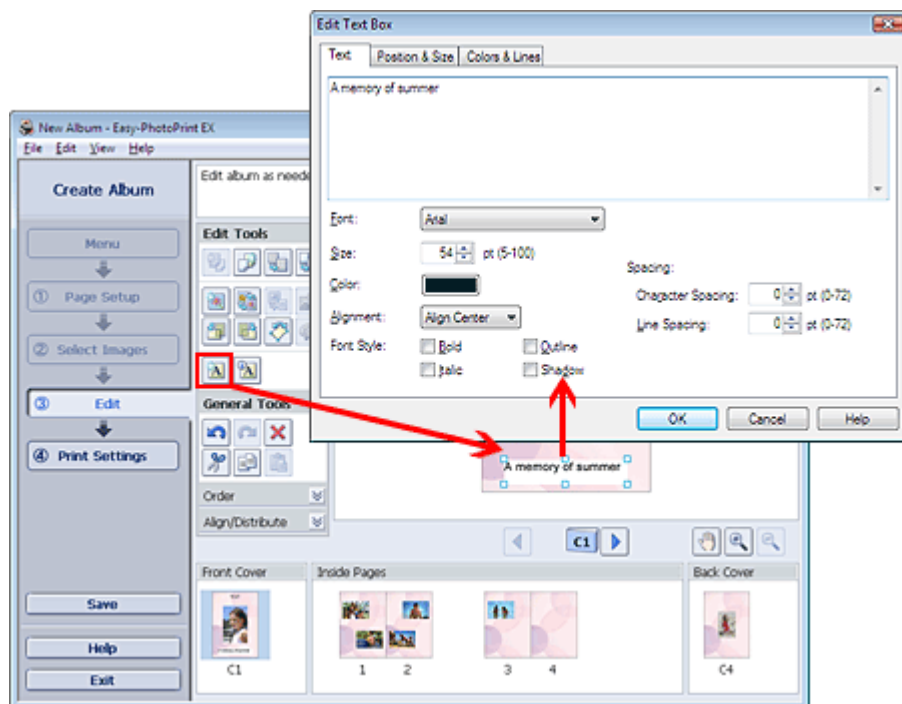

Select the Text tab in the Edit Text Box dialog box and enter text.

### Note

- In the Edit Text Box dialog box, you can change the position, angle and size of the text. You can also set the color and line of the text box. See Help for details.
- To change the entered text, select it and click  (Edit Text Box). The Edit Text Box dialog box appears. You can change the text.

## Advanced Guide

Advanced Guide > Printing from a Computer > Printing with the Bundled Application Software > Appendix 1: Easy-PhotoPrint EX Settings > Saving

## Saving

You can save edited items.

Click Save in the Edit or Print Settings screen.

### Note

- The screens for Album printing are used as examples in the following descriptions. The screens may vary depending on what you create.

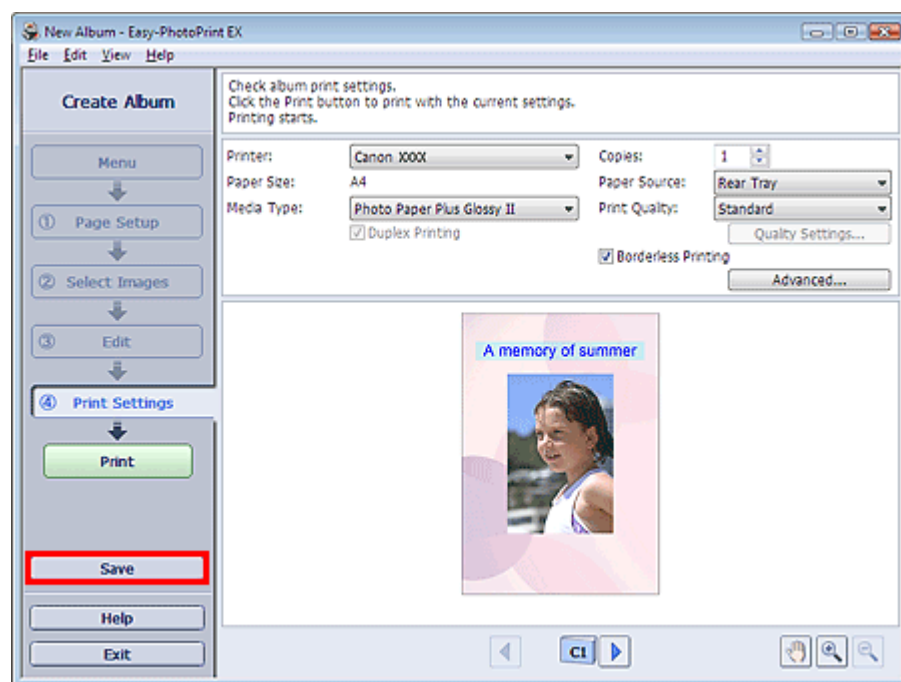

When the Save As dialog box appears, specify the save location and file name, then click Save.

### Important

- If you edit a saved file and save it again, the file will be overwritten.  
To save a file again with a new name or to a different location, select Save As... from the File menu and save.

### Note

- Save will not be displayed in the Page Setup or Select Images screen.

## Advanced Guide

Advanced Guide > Printing from a Computer > Printing with the Bundled Application Software > Appendix 1: Easy-PhotoPrint EX Settings > Setting Holidays

### Setting Holidays

You can add holidays to your calendar.

Click Set Holidays... in the Page Setup screen of Calendar, or click  (Setup Period/Holiday) in the Edit screen and click Set Holidays... in the Calendar General Settings dialog box to display the Holiday Settings dialog box.

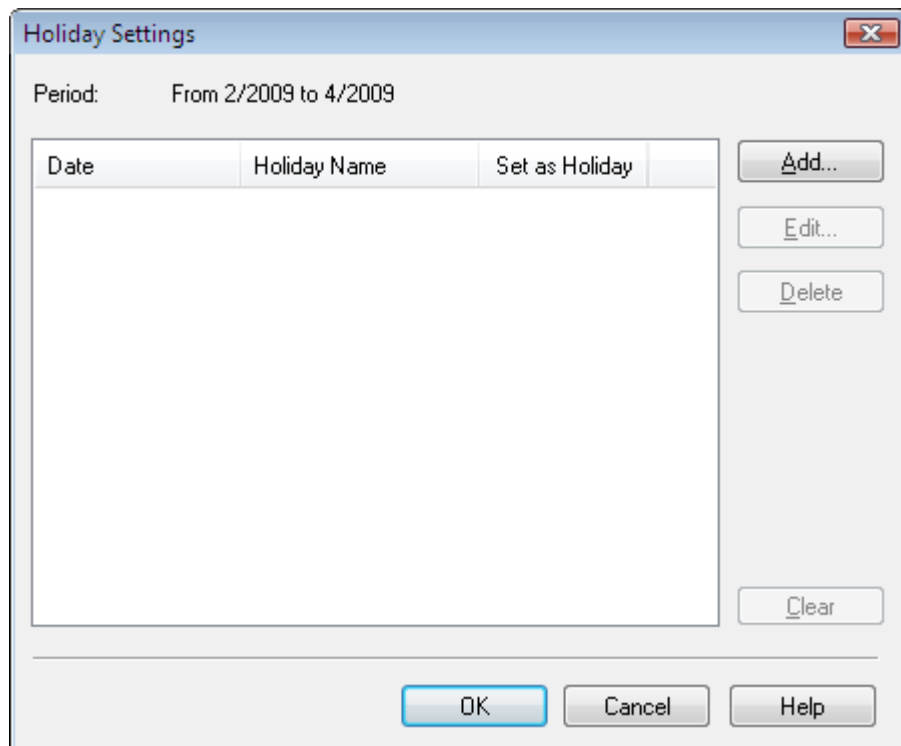

To add a holiday, click Add.... The Add/Edit Holiday dialog box appears. To edit a saved holiday, select it and click Edit....

To delete a holiday, select it and click Delete. To delete all the saved holidays within your calendar period, click Clear.

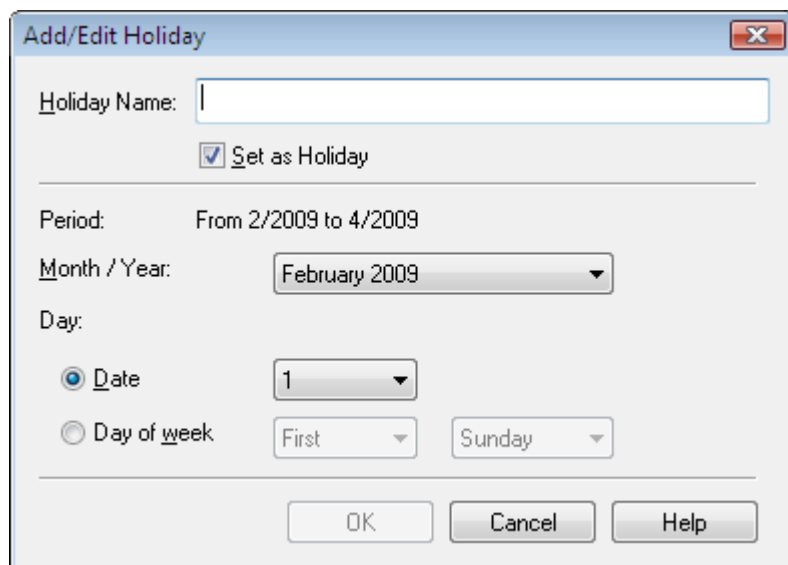

Enter the name in Holiday Name and specify the date.

Select the Set as Holiday checkbox to display that day as a holiday in your calendar.

- See Help for details on each dialog box.
- 

[Page top↑](#)



## Advanced Guide

Advanced Guide > Printing from a Computer > Printing with the Bundled Application Software > Appendix 1: Easy-PhotoPrint EX Settings > Setting Calendar Display

### Setting Calendar Display

You can customize the calendar display (fonts, lines, colors, position, size, etc.).

Click Settings... in the Page Setup screen of Calendar, or select a calendar in the Edit screen and click



(Setup Calendar) to display the Calendar Settings dialog box.

#### Important

- The Position & Size tab is displayed only when the Calendar Settings dialog box is displayed from the Edit screen.

Calendar Settings

Style Options Color Position & Size

Style for Year and Month

Font: Arial

Format: 3/2009

Style for Days of Week

Font: Arial

Week Starts on: Sunday

Style for Days

Font: Arial

Defaults

OK Cancel Help

#### Note

- See Help for details on the Calendar Settings dialog box.

## Advanced Guide

[Advanced Guide](#) > [Printing from a Computer](#) > [Printing with Other Application Software](#)

---

# Printing with Other Application Software

- ➔ [Various Printing Methods](#)
- ➔ [Changing the Print Quality and Correcting Image Data](#)
- ➔ [Overview of the Printer Driver](#)

[Page top](#) ↕

## Advanced Guide

Advanced Guide > Printing from a Computer > Printing with Other Application Software > Various Printing Methods

---

### Various Printing Methods

- ➔ [Printing with Easy Setup](#)
- ➔ [Setting a Page Size and Orientation](#)
- ➔ [Setting the Number of Copies and Printing Order](#)
- ➔ [Setting the Stapling Margin](#)
- ➔ [Borderless Printing](#)
- ➔ [Fit-to-Page Printing](#)
- ➔ [Scaled Printing](#)
- ➔ [Page Layout Printing](#)
- ➔ [Poster Printing](#)
- ➔ [Booklet Printing](#)
- ➔ [Duplex Printing](#)
- ➔ [Stamp/Background Printing](#)
- ➔ [Saving a Stamp Setting](#)
- ➔ [Saving Image Data to be Used as a Background](#)
- ➔ [Printing an Envelope](#)
- ➔ [Displaying the Print Results before Printing](#)
- ➔ [Setting Paper Dimensions \(Custom Size\)](#)

[Page top](#) ↕

## Advanced Guide

Advanced Guide > Printing from a Computer > Printing with Other Application Software > Various Printing Methods > Printing with Easy Setup

### Printing with Easy Setup

The procedure for setting the basic print setup, which is necessary to print data properly with this printer, is as follows:

1. Open the [printer driver setup window](#)
2. Select the media type

Select the type of paper loaded in the printer from the Media Type list on the Main tab.

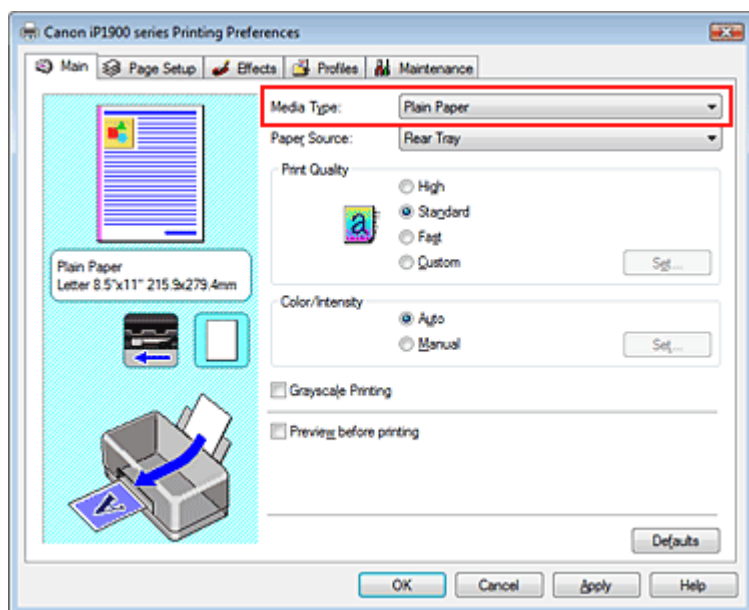

3. Select the print quality

Select High, Standard, or Fast for Print Quality.

4. Select color/intensity

Select Auto for Color/Intensity.

5. Check the settings

Check the specified settings such as paper type and the position of paper thickness lever displayed in the Settings Preview on the left side of the window.

6. Complete the setup

Click OK.

When you execute print, the document will be printed in accordance with the type of media.

## Advanced Guide

Advanced Guide > Printing from a Computer > Printing with Other Application Software > Various Printing Methods > Setting a Page Size and Orientation

### Setting a Page Size and Orientation

The paper size and orientation are essentially determined by the application. If the page size and orientation set for Page Size and Orientation on the Page Setup tab are same as those set with the application, you do not need to select them on the Page Setup tab.

If you are not able to specify them with the application, the procedure for selecting a page size and orientation is as follows:

1. Open the [printer driver setup window](#)
2. Select the paper size

Select a page size from the Page Size list on the Page Setup tab.

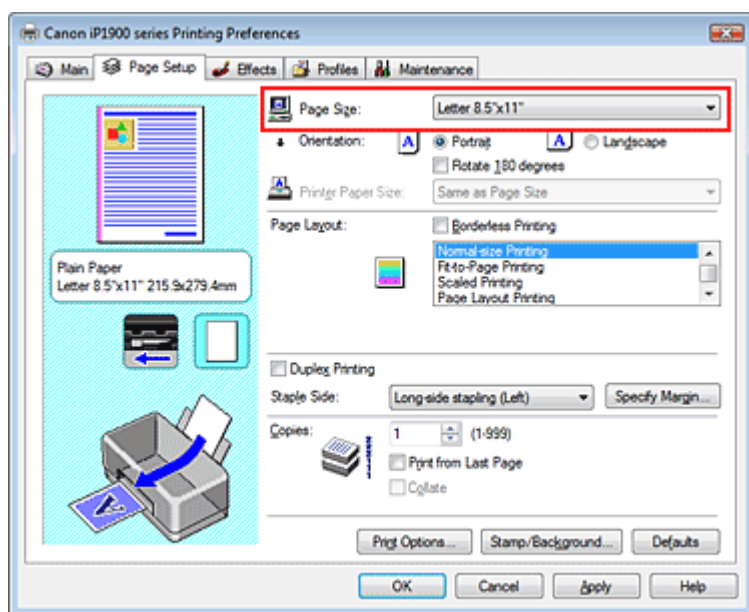

3. Select Orientation

Select Portrait or Landscape for Orientation. Check Rotate 180 degrees check box if you want to perform printing with the original being rotated 180 degrees.

4. Complete the setup

Click OK.

The document will be printed with the selected page size and the orientation.

## Advanced Guide

Advanced Guide > Printing from a Computer > Printing with Other Application Software > Various Printing Methods > Setting the Number of Copies and Printing Order

### Setting the Number of Copies and Printing Order

Default Setting

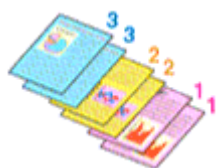

Print from Last Page

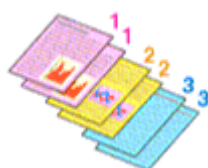

Collate

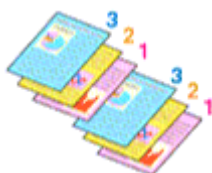

Print from Last Page + Collate

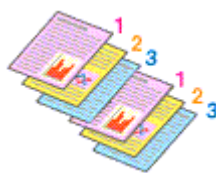

The procedure for specifying the number of copies and printing order is as follows:

1. Open the **printer driver setup window**
2. Specify the number of copies to be printed

For Copies on the Page Setup tab, specify the number of copies to be printed.

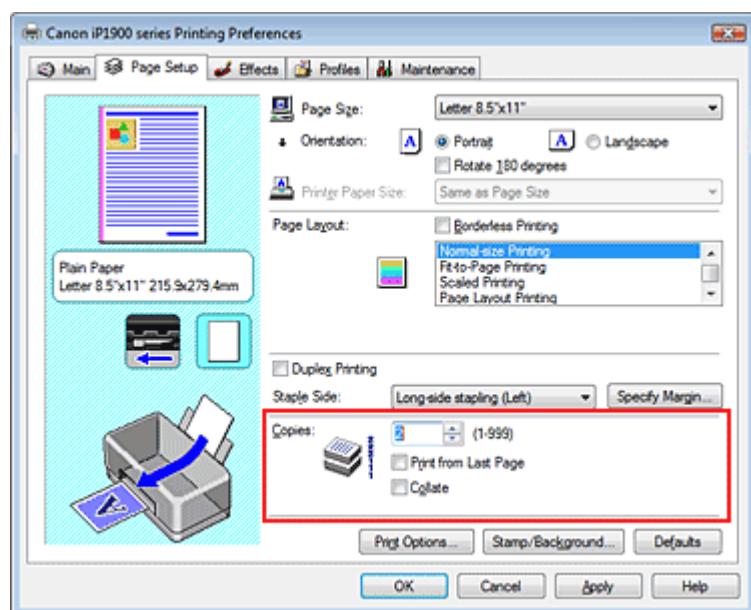

3. Specify the print sequence

Check the Print from Last Page check box if you want to print from the last page in order. If you do this, you do not need to sort pages into their correct order after printing.

4. Set up collated printing when you specify multiple copies in the Copies box

Check the Collate check box if you are specifying multiple copy together.  
Uncheck this check box to print all pages with the same page number together.

5. Complete the setup

Click OK.

The specified number of copies will be printed with the specified printing order.



**Important**

- If your application has the same function, make the settings with the application. If you specify the number of copies and the printing order with both the application and this printer driver, the number of copies may be multiplied numbers of the two settings or the specified printing order may not be enabled.
- Print from Last Page and Collate appear grayed out and are unavailable if Booklet Printing is selected for Page Layout.
- Print from Last Page appears grayed out and is unavailable if Poster Printing is selected for Page Layout.

---

 **Note**

- By setting both Print from Last Page and Collate, you can perform printing so that papers are collated one by one starting from the last page.  
These settings can be used in combination with Borderless Printing, Normal-size Printing, Fit-to-Page Printing, Scaled Printing, Page Layout Printing, and Duplex Printing.
- 

[Page top](#) ↑

## Advanced Guide

Advanced Guide > Printing from a Computer > Printing with Other Application Software > Various Printing Methods > Setting the Stapling Margin

### Setting the Stapling Margin

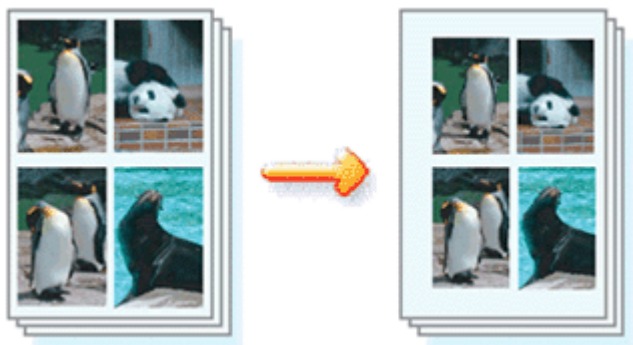

The procedure for setting the stapling direction and the width of the stapling margin is as follows:

1. Open the printer driver setup window
2. Specify the side to be stapled

Check the position of the stapling margin from Staple Side on the Page Setup tab.

The printer analyzes the Orientation and Page Layout settings, and automatically selects the best staple position. If you want to change the setting, select from the list.

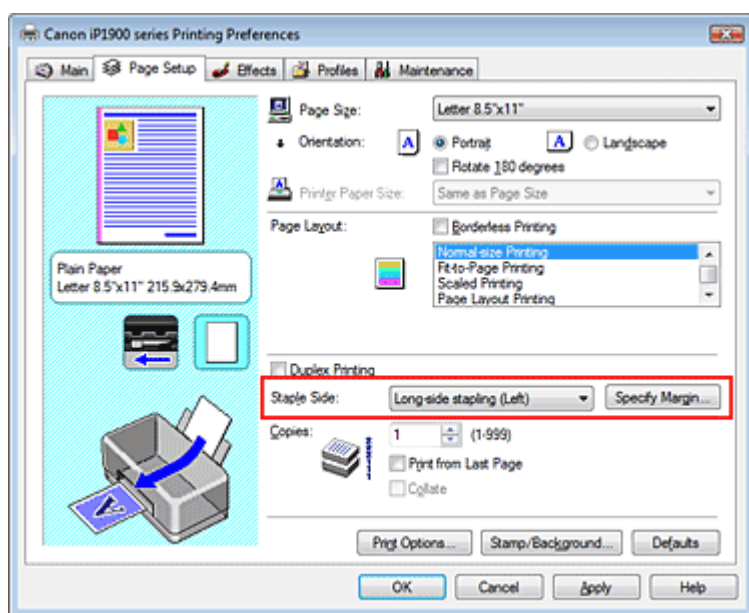

3. Set the margin width

If necessary, click Specify Margin... and set the width of the stapling margin, and then click OK.

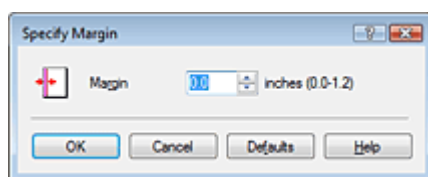

4. Complete the setup

Click OK on the Page Setup tab.

When you execute print, the data is printed with the specified staple side and margin.

#### Important

- Staple Side and Specify Margin... appear grayed out and are unavailable when:



- Poster Printing or Booklet Printing is selected for Page Layout.
- Scaled Printing is selected for Page Layout (If Duplex Printing is also selected, only Staple Side is selectable).
- Borderless Printing check box is checked (If Duplex Printing is also selected, only Staple Side is selectable).

[Page top](#) ↑

## Advanced Guide

Advanced Guide > Printing from a Computer > Printing with Other Application Software > Various Printing Methods > Borderless Printing

### Borderless Printing

The borderless printing function allows you to print data without any margin by enlarging the data so that it extends slightly off the paper. Without the borderless printing function, a margin is provided around the printed data. If you want to print data such as a photo without providing any margin around it, select Borderless Printing.

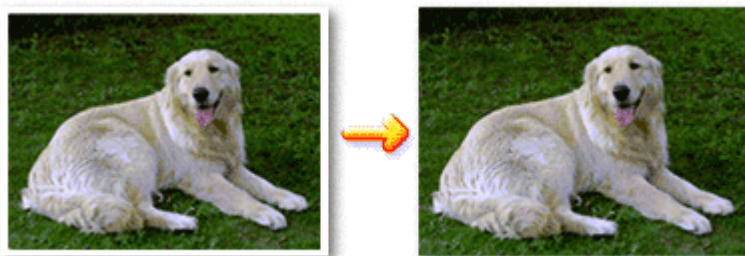

The procedure for performing borderless printing is as follows:

#### Setting Borderless Printing

1. Open the printer driver setup window

2. Set borderless printing

Check the Borderless Printing check box on the Page Setup tab.

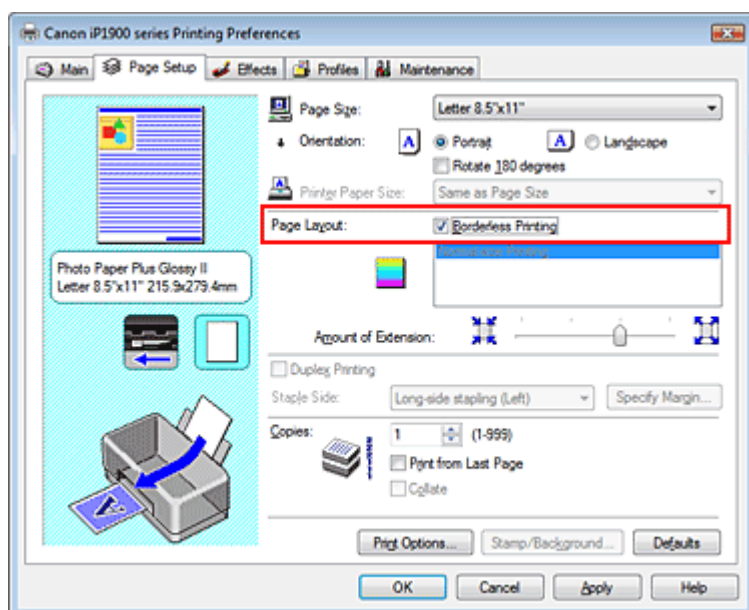

Click OK when the confirmation message appears.

When a message prompting you to change the media type appears, select a media type from the list and click OK.

3. Check the paper size

Check the Page Size list. If you want to change, select another page size from the list. The list displays only sizes that can be used for borderless printing.

4. Adjust the amount of extension from the paper

Adjust the amount of extension using the Amount of Extension slider as necessary.

Moving the slider to the right makes the amount larger and moving the slider to the left makes the amount smaller.

It is recommended to set the slider at the second position from the right for most cases.



### Important

- If you set the slider at the rightmost position, the back side of the paper may become smudged.

## 5. Complete the setup

Click OK.

The data will be printed without any margins on the paper.

### Important

- If a page size that cannot be used for borderless printing is selected, the size is automatically changed to the valid page sizes for borderless printing.
- When High Resolution Paper, T-Shirt Transfers, or Envelope is selected from the Media Type list on the Main tab, you cannot perform borderless printing.
- When Borderless Printing is checked, the Printer Paper Size, Page Layout, Staple Side (when Duplex Printing is not selected) settings, and the Stamp/Background... button on the Page Setup tab appear grayed out and are unavailable.
- Print quality may deteriorate or the sheet may be stained at the top and bottom depending on the type of the media used.
- When the ratio of the height to the width differs greatly from the image data, a portion of the image may not be printed depending on the size of the media used.  
In this case, crop the image data with an application software according to the paper size.

### Note

- When Plain Paper is selected for Media Type on the Main tab, borderless printing is not recommended, and therefore the dialog box for media selection appears.  
If you are using plain paper for test printing, select Plain Paper, and click OK.

## Expanding the range of the document to print

Specifying a large amount of extension allows you to perform borderless printing with no problems. However, the portion of the document that extends off the paper range will not be printed. Subjects around the perimeter of a photo may not be printed.

Try borderless printing once. If you are not satisfied with the result of borderless printing, reduce the amount of extension. The extension amount becomes shorter as the Amount of Extension slider is moved to the left.

### Important

- If the Amount of Extension is shortened, an unexpected margin may be produced on the print, depending on the size of the paper.

### Note

- If Preview before printing is checked on the Main tab, you can confirm before printing whether there will be no border.

## Advanced Guide

Advanced Guide > Printing from a Computer > Printing with Other Application Software > Various Printing Methods > Fit-to-Page Printing

### Fit-to-Page Printing



The procedure for printing document, which is enlarged or reduced to fit to the page size, is as follows:

#### 1. Open the printer driver setup window

#### 2. Set fit-to-page printing

Select Fit-to-Page Printing from the Page Layout list on the Page Setup tab.

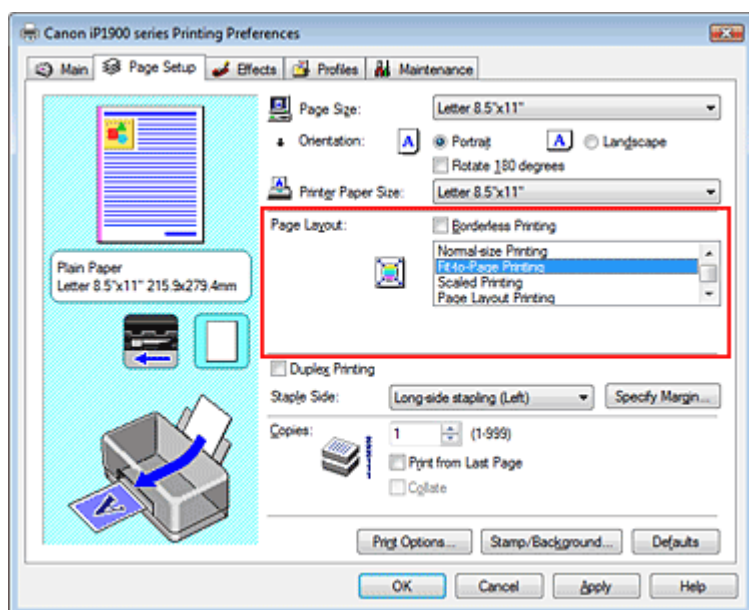

#### 3. Select the paper size for the data

Using Page Size, select the page size that was set with your application.

#### 4. Select the print paper size

Select the size of the paper loaded in the printer from the Printer Paper Size list.

If the printer paper size is smaller than the Page Size, the page image will be reduced. If the printer paper size is larger than the page size, the page image will be enlarged.

The current settings are displayed in the Settings Preview on the left side of the printer driver.

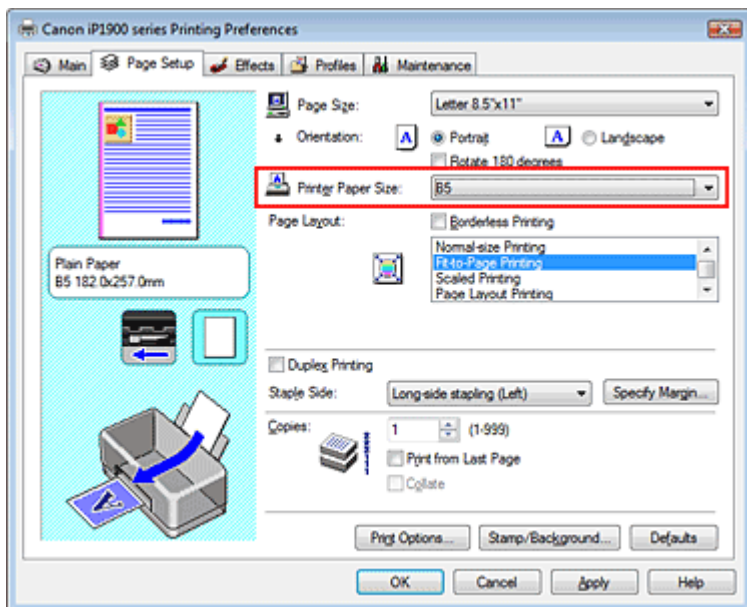

## 5. Complete the setup

Click OK.

When you execute print, the document will be enlarged or reduced to fit to the page size.

### Important

- When Borderless Printing check box is checked, Fit-to-Page Printing cannot be selected.

## Advanced Guide

Advanced Guide > Printing from a Computer > Printing with Other Application Software > Various Printing Methods > Scaled Printing

### Scaled Printing

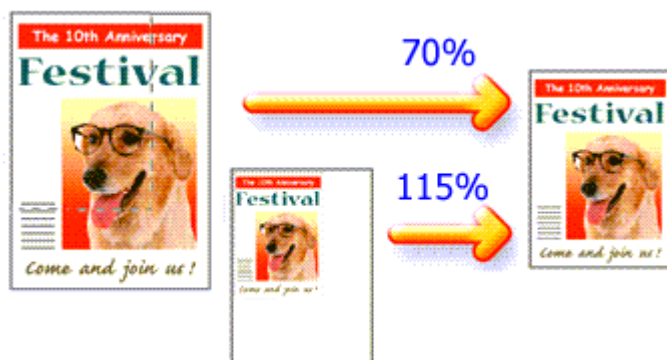

The procedure for printing a document with pages enlarged or reduced is as follows:

#### 1. Open the printer driver setup window

#### 2. Set scaled printing

Select Scaled Printing from the Page Layout list on the Page Setup tab.

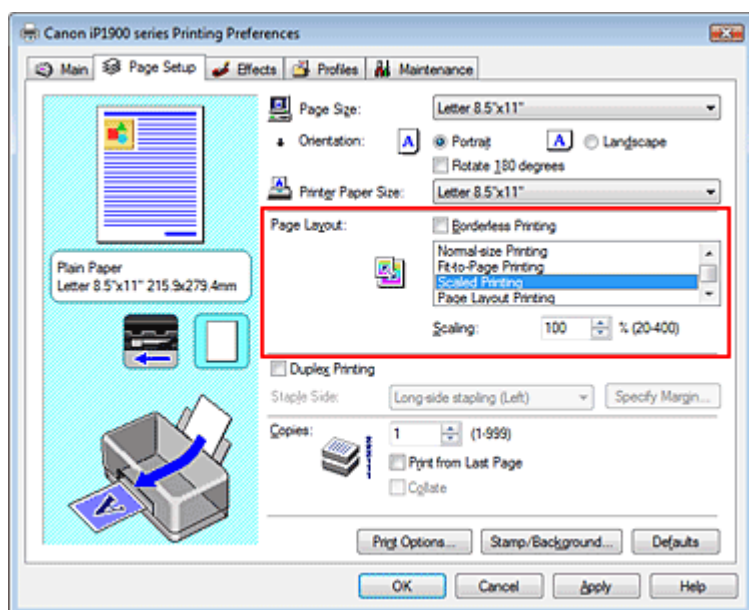

#### 3. Select the paper size for the data

Using Page Size, select the page size that was set with your application.

#### 4. Set the scaling rate by using one of the following methods:

- **Select a Printer Paper Size**

Select a printer paper size, which is different from the Page Size, from the Printer Paper Size list. If the printer paper size is smaller than the Page Size, the page image will be reduced. If the printer paper size is larger than the page size, the page image will be enlarged.

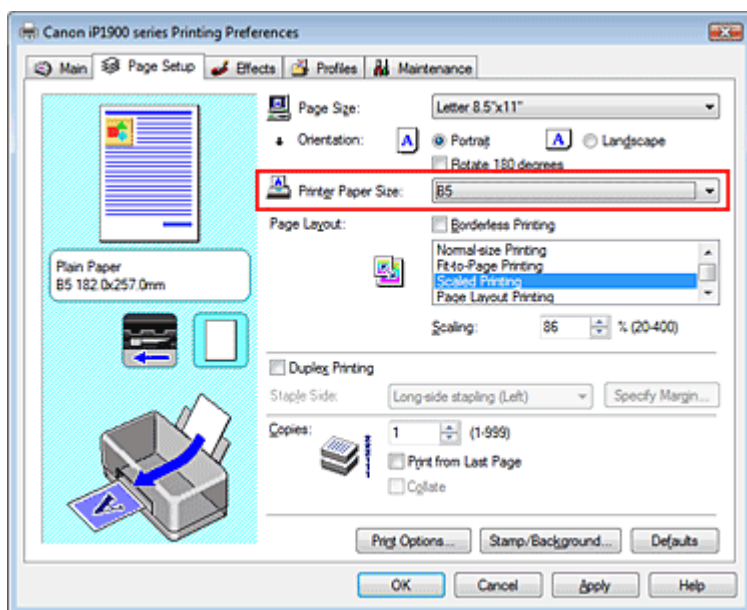

- **Specify a scaling factor**

Directly type in a value into the Scaling box.

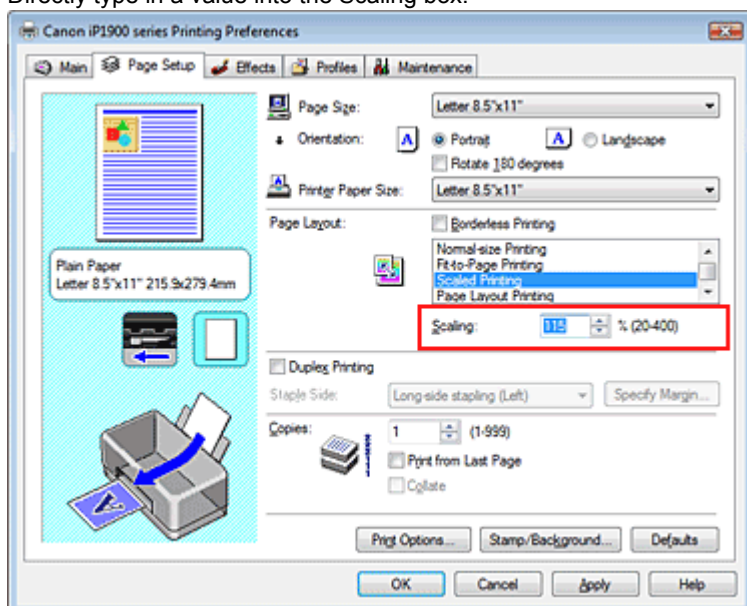

The current settings are displayed in the Settings Preview on the left side of the printer driver.

## 5. Complete the setup

Click OK.

When you execute print, the document will be printed with the specified scale.

### Important

- If the application software with which you created the original has the scaled printing function, configure the settings on your application software. You do not need to also configure the same setting in the printer driver.
- When Scaled Printing is selected, the Staple Side list box appears grayed out and is unavailable (when Duplex Printing is not selected).
- When Borderless Printing check box is checked, Scaled Printing cannot be selected.

### Note

- Selecting Scaled Printing changes the printable area.

## Advanced Guide

Advanced Guide > Printing from a Computer > Printing with Other Application Software > Various Printing Methods > Page Layout Printing

### Page Layout Printing

The page layout printing function allows you to print more than one page image on a single sheet of paper.



The procedure for performing page layout printing is as follows:

1. Open the **printer driver setup window**
2. Set page layout printing

Select Page Layout Printing from the Page Layout list on the Page Setup tab.

The current settings are displayed in the Settings Preview on the left side of the printer driver.

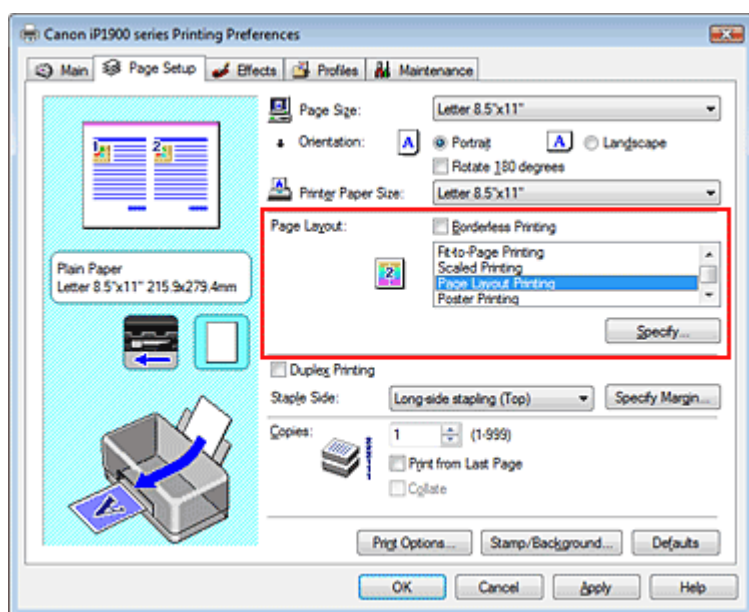

3. Select the print paper size

Select the size of the paper loaded in the printer from the Printer Paper Size list.

Now you have finished setting the layout of the document from left to right.

4. Set the number of pages to be printed on one sheet and the page sequence

If necessary, click Specify..., specify the following settings in the Page Layout Printing dialog box, and click OK.

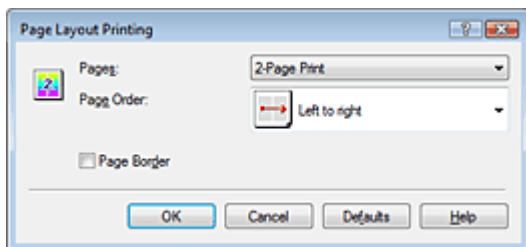

**Pages**

To increase the number of pages to be included on a single sheet of paper, select a desired number of pages from the list.

**Page Order**

To change the page arrangement order, select an icon from the list to change the page placement order.

**Page Border**

To print a page border around each document page, check this check box.

**5. Complete the setup**

Click OK on the Page Setup tab.

When you execute print, the specified number of pages will be arranged on each sheet of paper in the specified order.

**Important**

- When Borderless Printing check box is checked, Page Layout Printing cannot be selected.

## Advanced Guide

Advanced Guide > Printing from a Computer > Printing with Other Application Software > Various Printing Methods > Poster Printing

### Poster Printing

The poster printing function allows you to enlarge image data, divide it into several pages, and print these pages on separate sheets of paper. When the pages are pasted together, they form a large print like a poster.

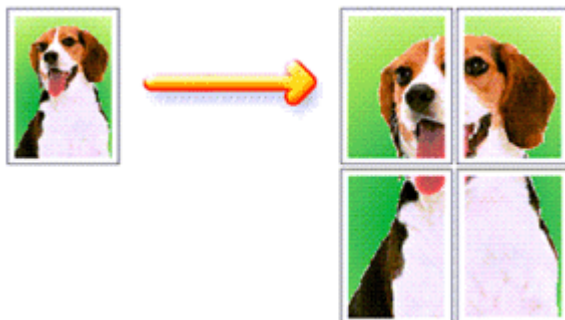

The procedure for performing poster printing is as follows:

#### Setting Poster Printing

##### 1. Open the printer driver setup window

##### 2. Set poster printing

Select Poster Printing from the Page Layout list on the Page Setup tab.

The current settings are displayed in the Settings Preview on the left side of the printer driver.

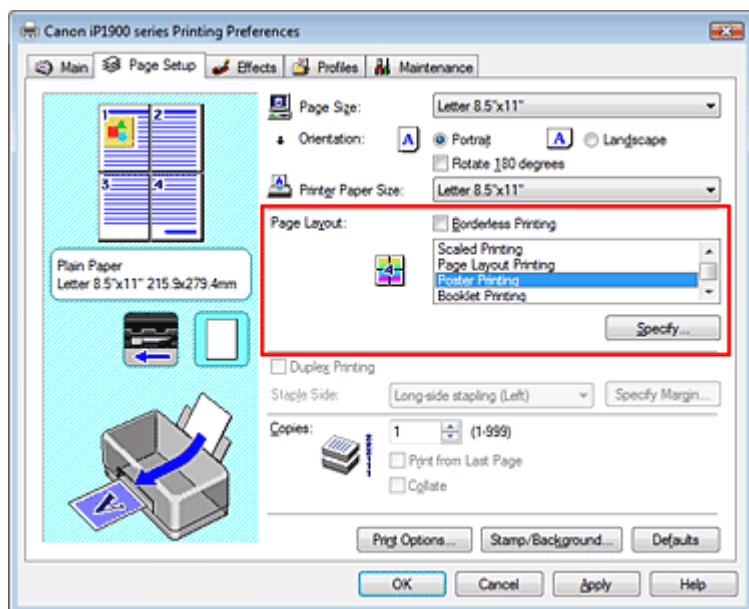

##### 3. Select the print paper size

Select the size of the paper loaded in the printer from the Printer Paper Size list.

Now you have finished setting 2 by 2-page poster printing.

##### 4. Set the number of image divisions and the pages to be printed.

If necessary, click Specify..., specify the following settings in the Poster Printing dialog box, and then click OK.

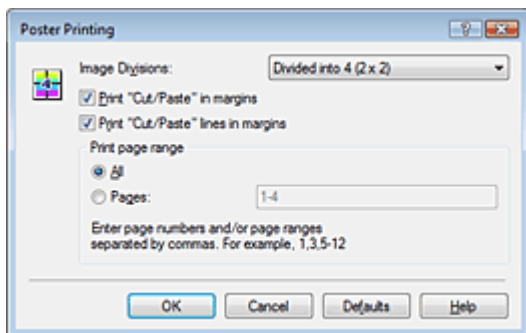

### Image Divisions

Select the number of divisions (vertical x horizontal) from the Image Divisions list. As the number of divisions increases, the number of sheets used for printing increases, allowing you to create a larger poster.

### Print "Cut/Paste" in margins

To leave out words "Cut" and "Paste", uncheck this check box.



### Important

- This feature is unavailable when the 64-bit printer driver is used.

### Print "Cut/Paste" lines in margins

To leave out cut lines, uncheck this check box.

### Pages

To reprint only specific pages, enter the page number you want to print. To print multiple pages, specify by separating the pages with commas or entering a hyphen between the page numbers.



### Note

- You can also specify the print range by clicking the pages in the setup preview.

## 5. Complete the setup

Click OK on the Page Setup tab.

When you execute print, the document will be divided into several pages during printing.

After all poster pages have been printed, paste the pages together to create a poster.

## Printing Only Specific Pages

If ink becomes faint or runs out during printing, you can print the pages you still need, by following the procedure below:

### 1. Set the print range

In the Settings Preview on the left of the Page Setup tab, click the pages that do not need to be printed.

The pages that were clicked are deleted, and only the pages to be printed are displayed.

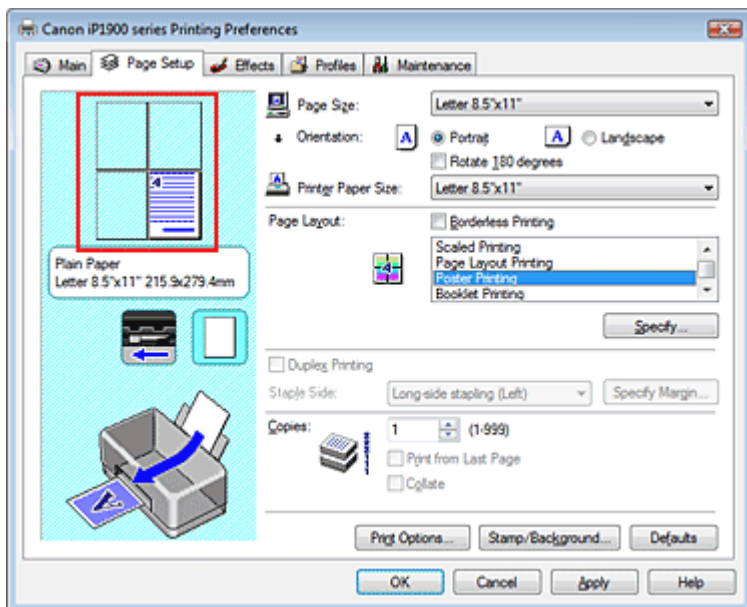

### Note

- Click the deleted pages to display them again.
- Right-click the Settings Preview to select Print all pages or Delete all pages.

## 2. Complete the setup

After completing the page selection, click OK.

When you execute print, only specified pages will be printed.

### Important

- When Poster Printing is selected, the Duplex Printing and Print from Last Page check boxes and the Staple Side list box appear grayed out and are unavailable.
- When Borderless Printing check box is checked, Poster Printing cannot be selected.
- Since poster printing enlarges the document when printing it, the print results may become coarse.

## Advanced Guide

Advanced Guide > Printing from a Computer > Printing with Other Application Software > Various Printing Methods > Booklet Printing

### Booklet Printing

The booklet printing function allows you to print data for a booklet. Data is printed on both sides of the paper. This type of printing ensures that pages can be collated properly, in page number order, when the printed sheets are folded and stapled at the center.

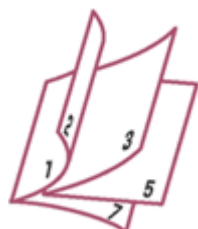

The procedure for performing booklet printing is as follows:

1. Open the printer driver setup window
2. Set booklet printing

Select Booklet Printing from the Page Layout list on the Page Setup tab.

The current settings are displayed in the Settings Preview on the left side of the window.

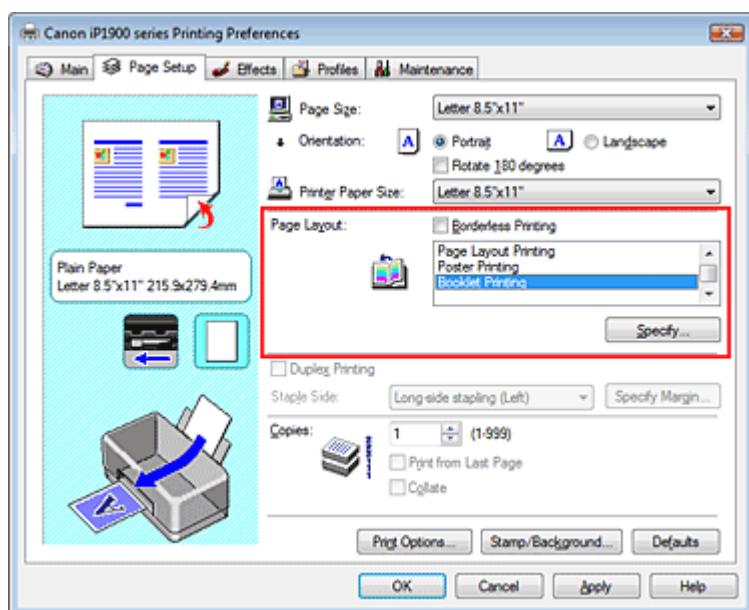

3. Select the print paper size

Select the size of the paper loaded in the printer from the Printer Paper Size list.

4. Set the margin for stapling and the margin width

Click Specify..., specify the following settings in the Booklet Printing dialog box, and then click OK.

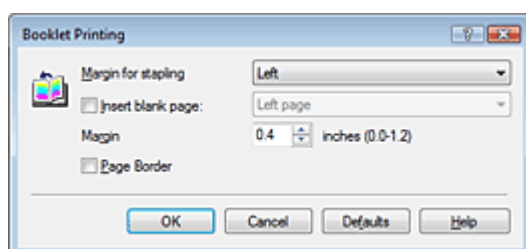

#### Margin for stapling

Select which side the stapling margin should be on when the booklet is completed.

**Insert blank page**

To leave one side of a sheet blank, check Insert blank page check box, and select the page to be left blank.

**Margin**

Enter the margin width. The specified width from the center of the sheet becomes the margin for one page.

**Page Border**

To print a page border around each document page, check the Page Border check box.

**5. Complete the setup**

Click OK on the Page Setup tab.

When you execute print, the document will be printed on one side of a sheet of paper. When the printing of one side is complete, set the paper correctly by following the message and click OK.

When the printing of the other side is complete, fold the paper at the center of the margin and make a booklet.

 **Important**

- Booklet Printing is unavailable when:
  - A media type other than Plain Paper is selected from the Media Type list.
  - Borderless Printing check box is checked.
- When Booklet Printing is selected, Duplex Printing, Staple Side, Print from Last Page, and Collate appear grayed out and are unavailable.

 **Note**

- The stamp and background are not printed on blank sheets inserted with the Insert blank page function of Booklet Printing.

## Advanced Guide

Advanced Guide > Printing from a Computer > Printing with Other Application Software > Various Printing Methods > Duplex Printing

## Duplex Printing

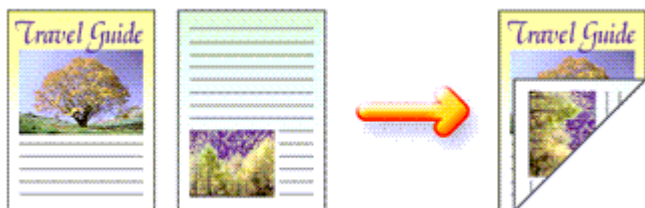

The procedure for printing data on both sides of a sheet of paper is as follows:

1. Open the **printer driver setup window**
2. Set duplex printing

Check the Duplex Printing check box on the Page Setup tab.

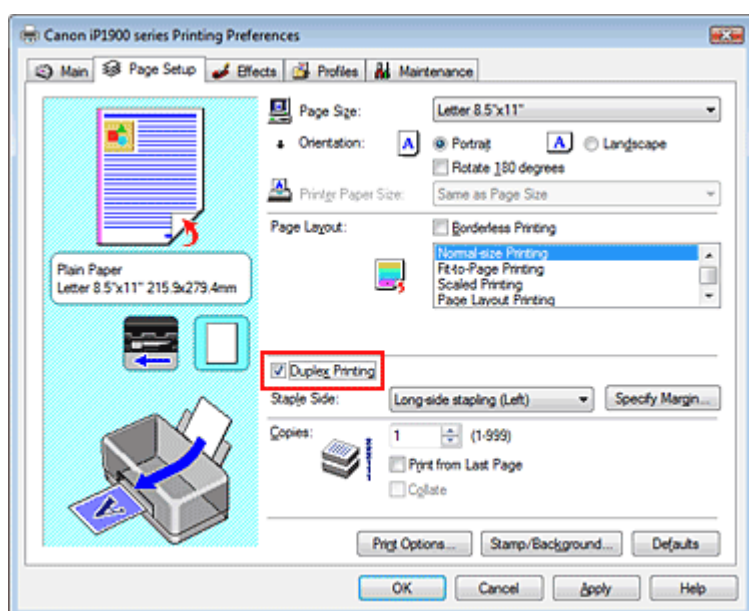

3. Select the layout

Select Normal-size Printing (or Fit-to-Page Printing, Scaled Printing, or Page Layout Printing) from the Page Layout list.

4. Specify the side to be stapled

The printer analyzes the Orientation and Page Layout settings, and automatically selects the best Staple Side. If you want to change the setting, select another value from the list.

5. Set the margin width

If necessary, click Specify Margin... and set the width of the stapling margin, and then click OK.

6. Complete the setup

Click OK on the Page Setup tab.

When you execute print, the document will be printed on one side of a sheet of paper. When the printing of one side is complete, set the paper correctly by following the message and click OK. The document will be printed on the opposite side.

- Duplex Printing is unavailable when:
  - A media type other than Plain Paper is selected from the Media Type list.
  - Poster Printing is selected from the Page Layout list.
- When Booklet Printing is selected from the Page Layout list, Duplex Printing and Staple Side appear grayed out and are unavailable.

---

 **Note**

- If the Media Type dialog box appears when performing borderless printing during duplex printing, select Plain Paper.
  - If the back side of the paper becomes smudged during duplex printing, perform Bottom Plate Cleaning in the Maintenance tab.
- 

[Page top](#) ↑



## Advanced Guide

Advanced Guide > Printing from a Computer > Printing with Other Application Software > Various Printing Methods > Stamp/Background Printing

### Stamp/Background Printing

This feature is unavailable when the 64-bit printer driver is used.

The Stamp function allows you to print a stamp text or a bitmap over or behind document data. The Background function allows you to print a light illustration behind the document data.

The procedure for performing stamp/background printing is as follows:

#### Printing a stamp

"CONFIDENTIAL," "IMPORTANT," and other stamps that are used often in companies are pre-registered.

1. Open the **printer driver setup window**
2. Click Stamp/Background... on the Page Setup tab

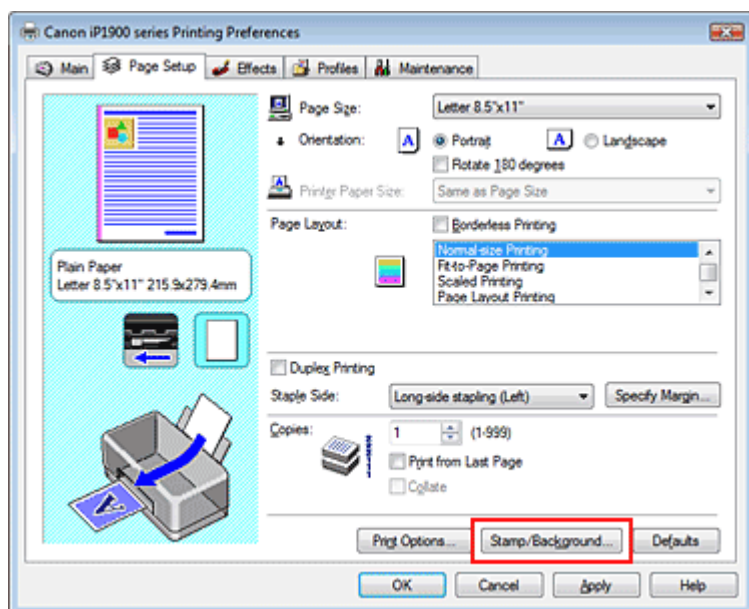

The Stamp/Background dialog box opens.

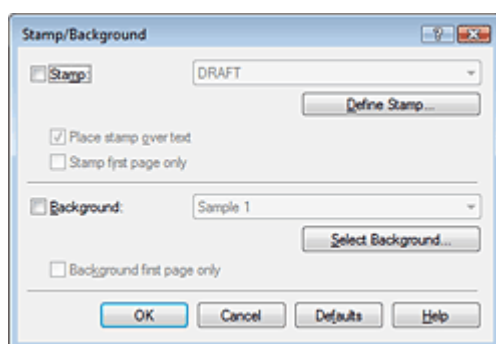

3. Select a stamp

Check the Stamp check box, and select a desired stamp from the list.

The current settings are displayed in the Settings Preview on the left side of the Page Setup tab.

4. Set the stamp details

If necessary, complete the following settings, and then click OK.

#### Place stamp over text

To print the stamp on the front of the document, check this check box.

 **Note**

- The stamp is given priority because the stamp is printed over the document data in the sections where the stamp and the document data overlap. If the Place stamp over text check box is unchecked, the stamp is printed behind the document data and may be hidden in the overlapping sections depending on the application used.

**Stamp first page only**

To print the stamp only on the first page, check this check box.

**Define Stamp... button**

To change the stamp text, bitmap, or position, click this (refer to Saving a Stamp Setting).

**5. Complete the setup**

Click OK on the Page Setup tab.

When you execute print, the data is printed with the specified stamp.

**Printing a background****1. Select the background for which the settings are to be changed**

Two bitmap files are pre-registered as samples.

**2. Click Stamp/Background... on the Page Setup tab**

The Stamp/Background dialog box opens.

**3. Select the background**

Check the Background check box, and select a desired background from the list.

The current settings are displayed in the Settings Preview on the left side of the Page Setup tab.

**4. Set the background details**

If necessary, complete the following settings, and then click OK.

**Background first page only**

To print the background only on the first page, check this check box.

**Select Background... button**

To use another bitmap file or change the layout or density of a background, click this (refer to [Saving Image Data to be Used as a Background](#)).

**5. Complete the setup**

Click OK on the Page Setup tab.

When you execute print, the data is printed with the specified background.

 **Important**

- When the Borderless Printing check box is checked, the Stamp/Background... button appears grayed out and is unavailable.

 **Note**

- The stamp and background are not printed on blank sheets inserted with the Insert blank page function of Booklet Printing.

**Related Topics**

➔ [Saving a Stamp Setting](#)

➔ [Saving Image Data to be Used as a Background](#)



## Advanced Guide

Advanced Guide > Printing from a Computer > Printing with Other Application Software > Various Printing Methods > Stamp/Background Printing > Saving a Stamp Setting

### Saving a Stamp Setting

This feature is unavailable when the 64-bit printer driver is used.

You can create and save a new stamp. You can also change and register some of the settings of an existing stamp. Unnecessary stamps can be deleted at any time.

The procedure for registering a new stamp is as follows:

#### Registering a new stamp

1. Open the [printer driver setup window](#)
2. Click Stamp/Background... on the Page Setup tab

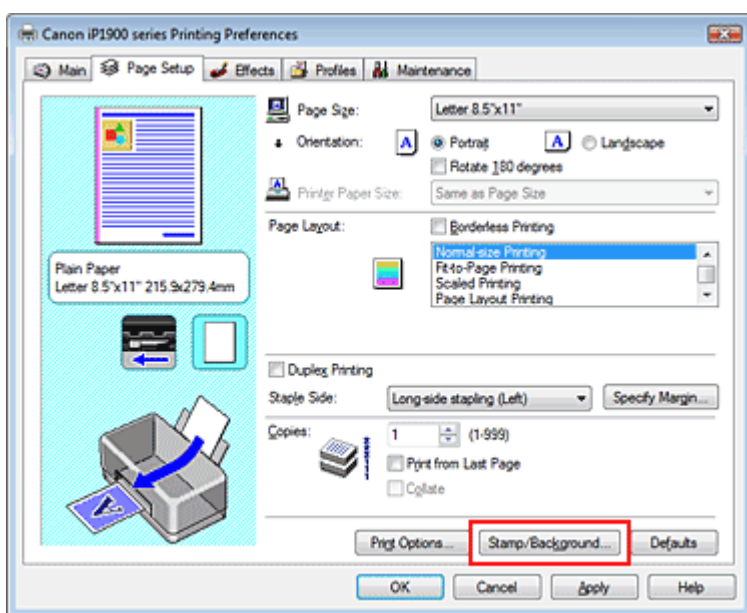

The Stamp/Background dialog box opens.

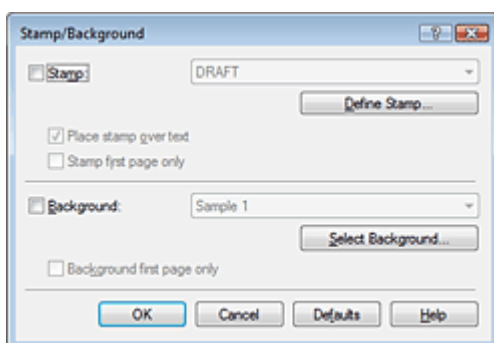

3. Click Define Stamp...

The Stamp Settings dialog box opens.

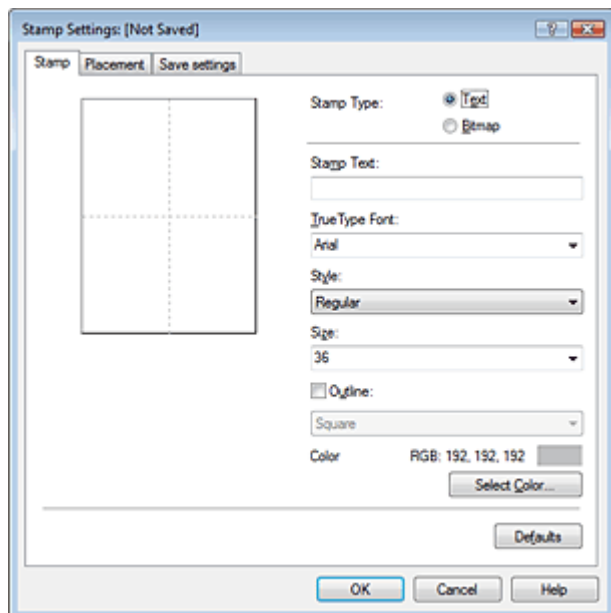

#### 4. Configure the stamp while viewing the preview window

- **Stamp tab**

Select Text or Bitmap with Stamp Type.

When registering a text, the characters must already be entered in Stamp Text. Change the True Type Font, Style, Size, and Outline settings, as necessary. You can select the color of the stamp by clicking Select Color...

For Bitmap, click Select File... and select the bitmap file (.bmp) to be used. Change the settings of the Size and Transparent white area if necessary.

- **Placement tab**

Select the stamp position from the Position list. You can also select Custom from the Position list and specify coordinates for X-Position and Y-Position.

You can also change the stamp position by dragging the stamp in the preview window.

To change the stamp position angle, type a value in the Orientation box directly.

#### 5. Save the stamp

Click the Save settings tab and enter a new stamp title in the Title box, and then click Save.

Click OK when the confirmation message appears.

#### 6. Complete the setup

Click OK. The Stamp/Background dialog box opens again.

The registered title appears in the Stamp list.

### Changing and registering some of stamp settings

#### 1. Select the stamp for which the settings are to be changed

Check the Stamp check box in the Stamp/Background dialog box, and then select the title of the stamp to be changed from the Stamp list.

#### 2. Click Define Stamp...

The Stamp Settings dialog box opens.

#### 3. Configure the stamp while viewing the preview window

#### 4. Save the stamp

Click Save overwrite on the Save settings tab.

If you want to save the stamp with a different title, type a new title in the Title box and click Save.

Click OK when the confirmation message appears.

#### 5. Complete the setup

Click OK. The Stamp/Background dialog box opens again.  
The registered title appears in the Stamp list.

### Deleting an unnecessary stamp

#### 1. Click Define Stamp... in the Stamp/Background dialog box

The Stamp Settings dialog box opens.

#### 2. Select the stamp to be deleted

Select the title of the stamp you want to delete from the Stamps list on the Save settings tab. Then click Delete.

Click OK when the confirmation message appears.

#### 3. Complete the setup

Click OK. The Stamp/Background dialog box opens again.



[Page top](#) ↑

## Advanced Guide

Advanced Guide > Printing from a Computer > Printing with Other Application Software > Various Printing Methods > Stamp/Background Printing > Saving Image Data to be Used as a Background

### Saving Image Data to be Used as a Background

This feature is unavailable when the 64-bit printer driver is used.

You can select a bitmap file and save it as a new background. You can also change and register some of the settings of an existing background. An unnecessary background can be deleted at any time.

The procedure for registering image data to be used as a background is as follows:

#### Registering image data to be used as a background

1. Open the [printer driver setup window](#)
2. Click Stamp/Background... on the Page Setup tab

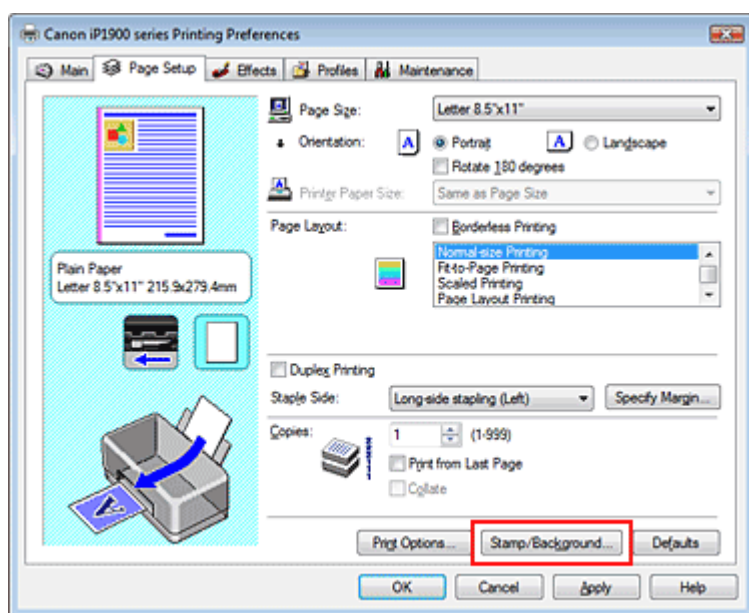

The Stamp/Background dialog box opens.

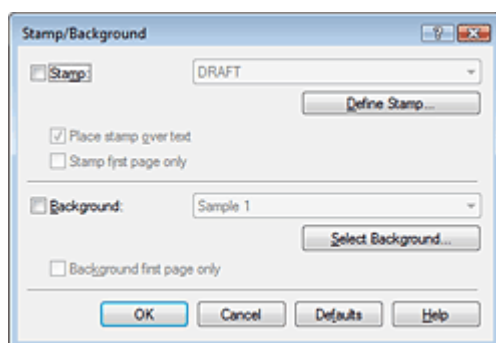

3. Click [Select Background...](#)

The Background Settings dialog box opens.

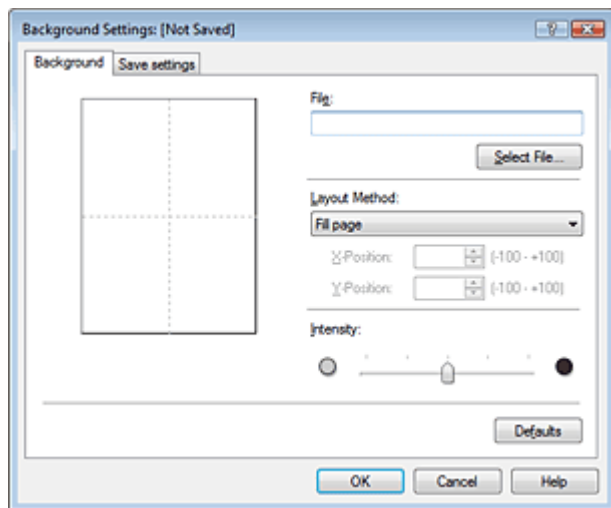

#### 4. Select the image data to be registered to the background

Click Select File.... Select the target image data (bitmap file), and then click Open.

#### 5. Specify the following settings while viewing the preview window

##### Layout Method

Select how the background image data is to be placed.

When Custom is selected, you can set coordinates for X-Position and Y-Position.

You can also change the background position by dragging the image in the preview window.

##### Intensity

Set the intensity of the background image data with the Intensity slider. To lighten the background, move the slider to the left. To darken the background, move the slider to the right. To print the background at the original bitmap intensity, move the slider to the rightmost position.

#### 6. Save the background

Click the Save settings tab and enter a new stamp title in the Title box, and then click Save.

Click OK when the confirmation message appears.

#### 7. Complete the setup

Click OK. The Stamp/Background dialog box opens again.

The registered title appears in the Background list.

### Changing and saving some background settings

#### 1. Select the background for which the settings are to be changed

Check the Background check box in the Stamp/Background dialog box, and then select the title of the background you want to change from the Background list.

#### 2. Click Select Background...

The Background Settings dialog box opens.

#### 3. While viewing the preview, set the items on the Background tab

#### 4. Save the background

Click Save overwrite on the Save settings tab. If you want to save the background with a different title, type a new title in the Title box and click Save.

Click OK when the confirmation message appears.

#### 5. Complete the setup

Click OK. The Stamp/Background dialog box opens again.

The registered title appears in the Background list.

### Deleting an unnecessary background

**1.** Click Select Background... in the Stamp/Background dialog box

The Background Settings dialog box opens.

**2.** Select the background to be deleted

Select the title of the background you want to delete from the Backgrounds list on the Save settings tab, and then click Delete.

Click OK when the confirmation message appears.

**3.** Complete the setup

Click OK. The Stamp/Background dialog box opens again.



[Page top](#) ↑



## Advanced Guide

Advanced Guide > Printing from a Computer > Printing with Other Application Software > Various Printing Methods > Printing an Envelope

### Printing an Envelope

For details on how to load an envelope into the machine, refer to the "Loading Envelopes" in the manual: Basic Guide.

The procedure for performing envelope printing is as follows:

#### 1. Load an envelop into the printer

Fold down the envelope flap.

Orient the envelope so that the flap is on the left and the folded surface is facing down.

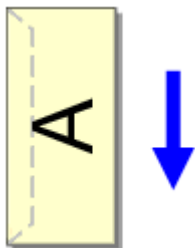

#### 2. Open the printer driver setup window

#### 3. Select the media type

Select Envelope from the Media Type list on the Main tab.

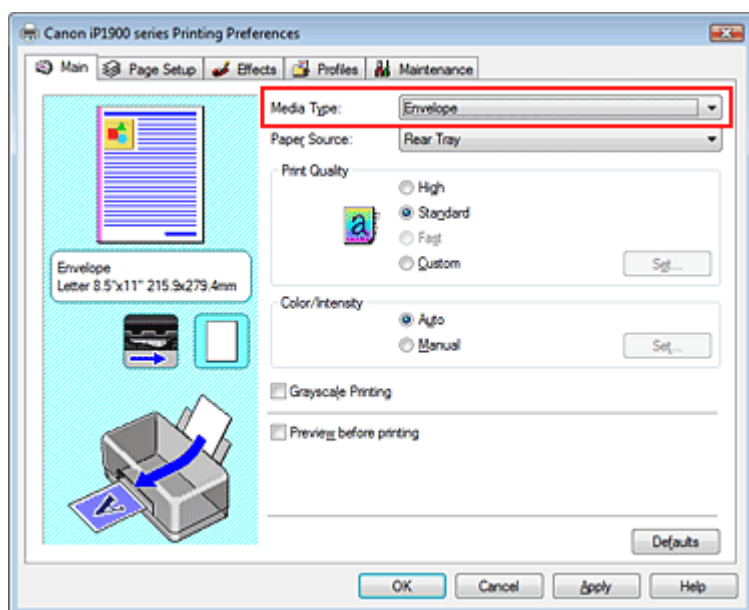

#### 4. Select the paper size

Click the Page Setup tab, and select Youkei 4, Youkei 6, Comm.Env. #10, or DL Env. for Page Size.

#### 5. Select the landscape for orientation

To print the addressee horizontally, select Landscape for Orientation.

#### 6. Complete the setup

Click OK.

When you execute print, the information is printed on the envelope.

## Advanced Guide

Advanced Guide > Printing from a Computer > Printing with Other Application Software > Various Printing Methods > Displaying the Print Results before Printing

# Displaying the Print Results before Printing

You can display and check the print result before printing.

The procedure for displaying the print result before printing is as follows:

1. Open the [printer driver setup window](#)
2. Set the preview

Check the Preview before printing check box on the Main tab.

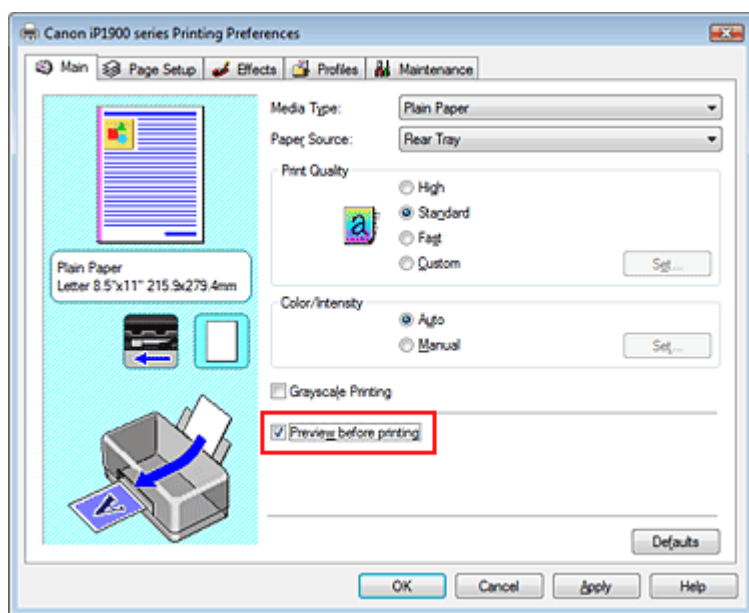

3. Complete the setup

Click OK.

The Canon IJ Preview will start and the print result will be displayed before printing.

## Related Topic

➔ [Canon IJ Preview](#)

## Advanced Guide

Advanced Guide > Printing from a Computer > Printing with Other Application Software > Various Printing Methods > Setting Paper Dimensions (Custom Size)

### Setting Paper Dimensions (Custom Size)

You can specify the height and width of paper if its size cannot be selected in Page Size. Such a paper size is called a custom size.

The procedure for specifying a custom size is as follows:

#### 1. Set the custom size in the application software

On your application's paper size feature, specify your custom size.

#### Important

- If the application software that created the document has a function for specifying the height and width values, use the application software to set the values. If the application software does not have such a function or if the document does not print correctly, use the printer driver to set the values.

#### 2. Open the printer driver setup window

#### 3. Select the paper size

Select Custom... for Page Size on the Page Setup tab.

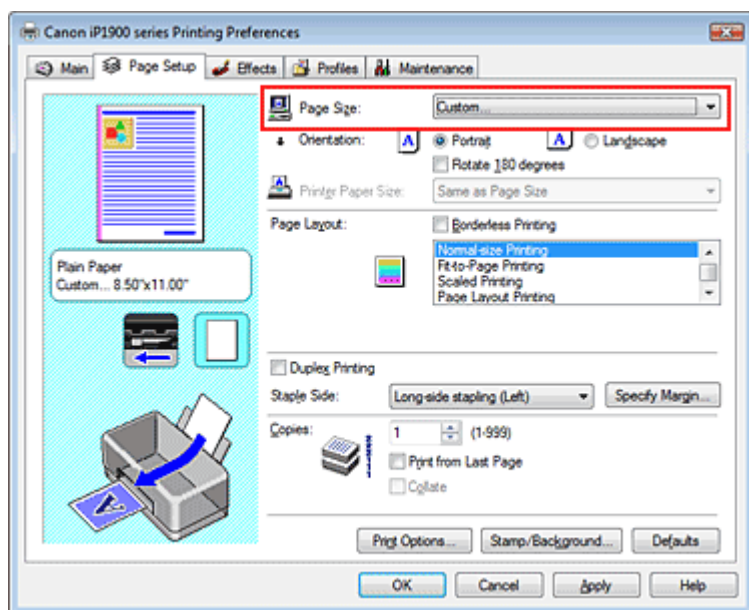

The Custom Paper Size dialog box opens.

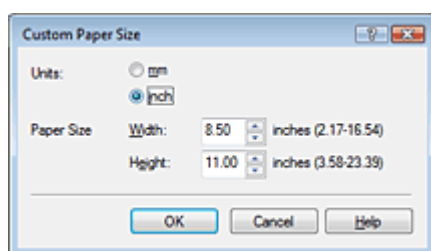

#### 4. Set the custom size in the application software

Specify Units, and enter the Width and Height of the paper to be used. Then click OK.

#### 5. Complete the setup

Click OK on the Page Setup tab.

When you execute print, the data is printed with the specified paper size.



## Advanced Guide

Advanced Guide > Printing from a Computer > Printing with Other Application Software > Changing the Print Quality and Correcting Image Data

---

### Changing the Print Quality and Correcting Image Data

- ➔ Selecting a Combination of the Print Quality Level and a Halftoning Method
- ➔ Printing a Color Document in Monochrome
- ➔ Specifying Color Correction
- ➔ Optimal Photo Printing of Image Data
- ➔ Adjusting Colors with the Printer Driver
- ➔ Printing with ICC Profiles
- ➔ Adjusting Color Balance
- ➔ Adjusting Brightness
- ➔ Adjusting Intensity
- ➔ Adjusting Contrast
- ➔ Simulating an Illustration
- ➔ Representing Image Data with a Single Color
- ➔ Presenting Image Data with Vivid Colors
- ➔ Smoothing Jagged Outlines
- ➔ Changing Color Properties to Improve Coloration
- ➔ Reducing Photo Noise

[Page top ↕](#)

## Advanced Guide

Advanced Guide > Printing from a Computer > Printing with Other Application Software > Changing the Print Quality and Correcting Image Data > Selecting a Combination of the Print Quality Level and a Halftoning Method

### Selecting a Combination of the Print Quality Level and a Halftoning Method

You can set the print quality level and the halftoning method.



The procedure for setting the print quality level and the halftoning method is as follows:

#### 1. Open the printer driver setup window

#### 2. Select the print quality

Select Custom for Print Quality on the Main tab, and click Set...

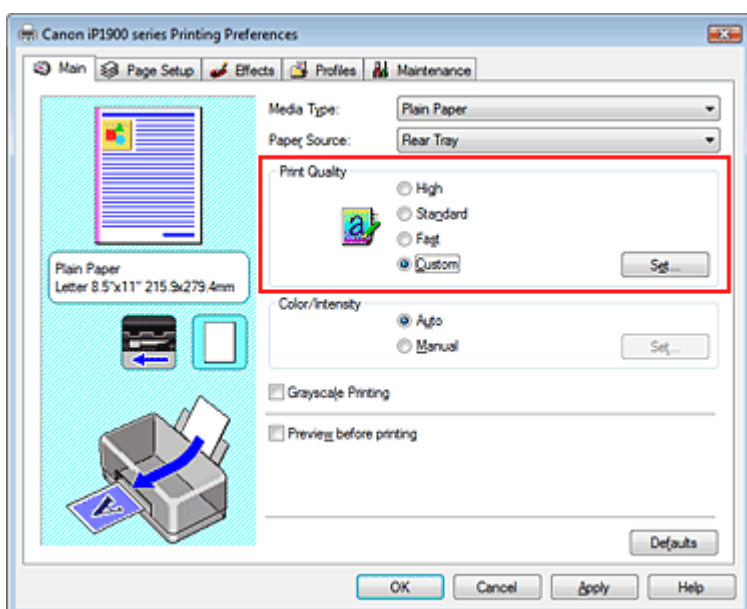

The Custom dialog box opens.

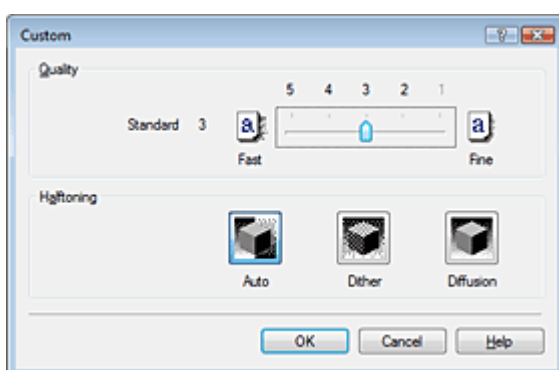

#### 3. Setting the print quality and halftone expression method

Move the Quality slider to select the quality level.  
Select Halftoning and click OK.

- Halftones refer to color shades between the darkest color and the brightest color. The printer replaces the color shades with a collection of small dots to express the halftones. Dither arranges the dots according to fixed rules to express the halftones. Diffusion places the dots randomly to express the halftones. When you select Auto, the data is printed with the optimal halftoning method for the selected print quality.
- 

#### 4. Complete the setup

Click OK on the Main tab.

When you execute print, the data is printed with the specified quality level and halftoning method.

#### Important

- Certain print quality levels and halftoning methods cannot be selected depending on the settings of Media Type.

#### Note

- When the part of the object is not printed, selecting Diffusion for Halftoning may solve the problem.
- 

#### Related Topics

- ➔ [Specifying Color Correction](#)
- ➔ [Adjusting Color Balance](#)
- ➔ [Adjusting Brightness](#)
- ➔ [Adjusting Intensity](#)
- ➔ [Adjusting Contrast](#)

## Advanced Guide

Advanced Guide > Printing from a Computer > Printing with Other Application Software > Changing the Print Quality and Correcting Image Data > Printing a Color Document in Monochrome

## Printing a Color Document in Monochrome

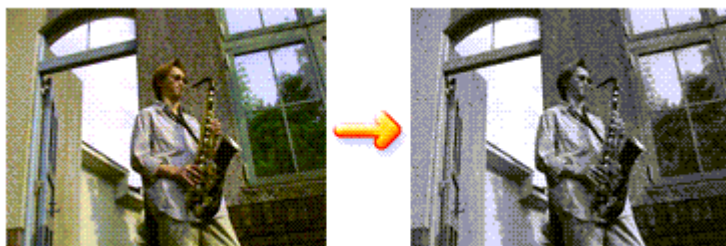

The procedure for printing a color document in monochrome is as follows:

1. Open the [printer driver setup window](#)
2. Set grayscale printing

Check the Grayscale Printing check box on the Main tab.

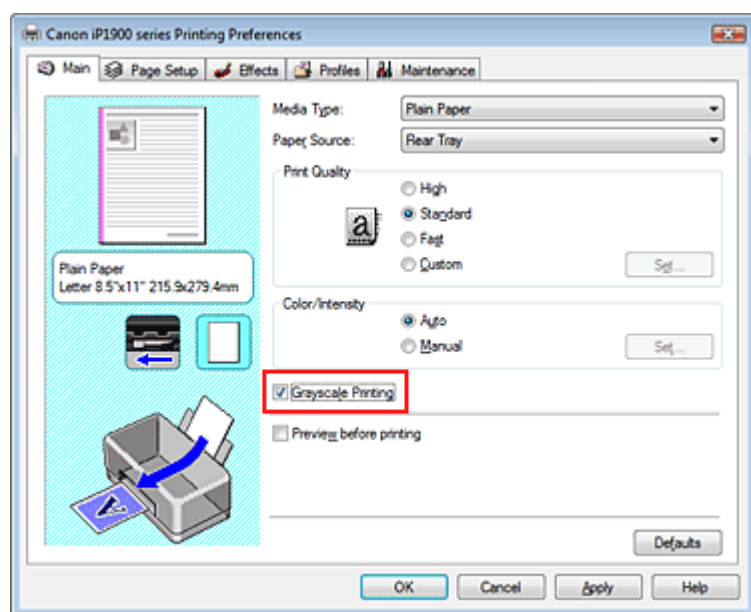

3. Complete the setup

Click OK.

When you execute print, the document is converted to grayscale data. It allows you to print the color document in monochrome.

### Important

- When the Grayscale Printing check box is checked, the printer driver processes image data as sRGB data. In this case, actual colors printed may differ from those in the original image data. When using the grayscale printing function to print Adobe RGB data, convert the data to sRGB data using an application software.

### Note

- During Grayscale Printing, color inks may be used as well as black ink.



## Advanced Guide

Advanced Guide > Printing from a Computer > Printing with Other Application Software > Changing the Print Quality and Correcting Image Data > Specifying Color Correction

### Specifying Color Correction

You can specify the color correction method suited to the type of document to be printed.

Normally, the printer driver adjusts the colors by using Canon Digital Photo Color so that data is printed with color tints that most people prefer. This method is suitable for printing sRGB data.

If you want to print by using the color space of sRGB or Adobe RGB data effectively, select ICM. If you want to use an application software to specify an ICC profile, select None.

The procedure for specifying color correction is as follows:

1. Open the [printer driver setup window](#)

2. Select the manual color adjustment

On the Main tab, select Manual for Color/Intensity, and click Set....

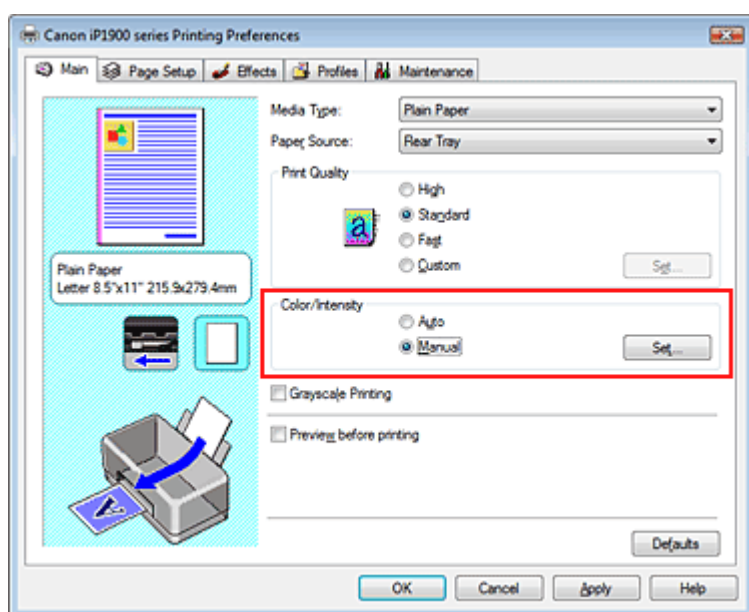

The Manual Color Adjustment dialog box opens.

3. Select color correction

Click Matching tab, select Color Correction setting suited to your purpose from the following, and click OK.

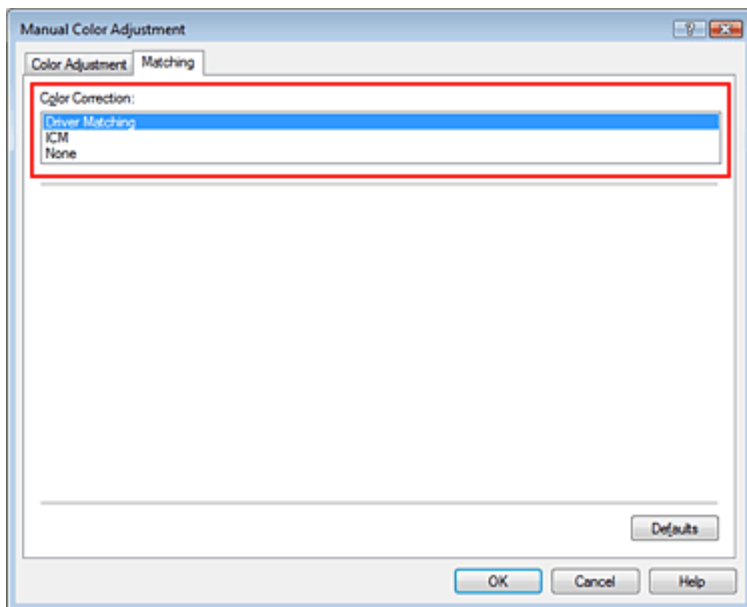

### Driver Matching

By using Canon Digital Photo Color, you can print sRGB data with color tints that most people prefer.

Driver Matching is the default setting for Color Correction.

### ICM

You can print by using the color space of sRGB or Adobe RGB data effectively.

### None

The printer driver does not perform color adjustment. Select this value if you are specifying an individually created profile or a profile for special Canon paper in an application software to print data.

## 4. Complete the setup

Click OK on the Main tab.

When you execute print, the data is printed with the specified color adjustment method.

### Important

- If ICM is disabled in the application software, ICM is unavailable for Color Correction and the printer may not be able to print the image data properly.
- When the Grayscale Printing check box on the Main tab is checked, Color Correction appears grayed out and is unavailable.

### Related Topics

- ➔ [Optimal Photo Printing of Image Data](#)
- ➔ [Adjusting Colors with the Printer Driver](#)
- ➔ [Printing with ICC Profiles](#)



## Advanced Guide

[Advanced Guide](#) > [Printing from a Computer](#) > [Printing with Other Application Software](#) > [Changing the Print Quality and Correcting Image Data](#) > [Specifying Color Correction](#) > [Optimal Photo Printing of Image Data](#)

# Optimal Photo Printing of Image Data

When people print images taken with digital cameras, they sometimes feel that the printed color tones differ from those of actual image or those displayed on the monitor.

To get the print results as close as possible to the desired color tones, you must select a printing method that is best suited to the application software used or to your purpose.

## Color Management

Devices such as digital cameras, scanners, monitors, and printers handle color differently. Color management (color matching) is a method that manages device-dependent "colors" as a common color space. For Windows, a color management system called "ICM" is built into the operating system. sRGB and Adobe RGB are popularly used as common color spaces. Adobe RGB has a wider color space than sRGB.

ICC profiles convert device-dependent "colors" into a common color space.

By using an ICC profile and carrying out color management, you can draw out the color space of the image data within the color reproduction area that the printer can express.

## Selecting a printing method suited to the image data

The recommended printing method depends on the color space (Adobe RGB or sRGB) of the image data or the application software to be used. There are two typical printing methods. Check the color space (Adobe RGB or sRGB) of the image data and the application software to be used, and then select the printing method suited to your purpose.

- **To print using Canon Digital Photo Color**

Target data: sRGB data

Printing method: [Adjusting Colors with the Printer Driver](#)

- **To print using the color space of the data effectively**

Target data: Adobe RGB data or sRGB data

Application software: An ICC profile can or cannot be specified.

Printing method: [Printing with ICC Profiles](#)



## Advanced Guide

Advanced Guide > Printing from a Computer > Printing with Other Application Software > Changing the Print Quality and Correcting Image Data > Specifying Color Correction > Adjusting Colors with the Printer Driver

### Adjusting Colors with the Printer Driver

You can specify the color correction function of the printer driver to print sRGB data with color tints that most people prefer (through the use of Canon Digital Photo Color).

The procedure for adjusting colors with the printer driver is as follows:

#### 1. Open the printer driver setup window

#### 2. Select the media type

Select the type of paper loaded in the printer from the Media Type list on the Main tab.

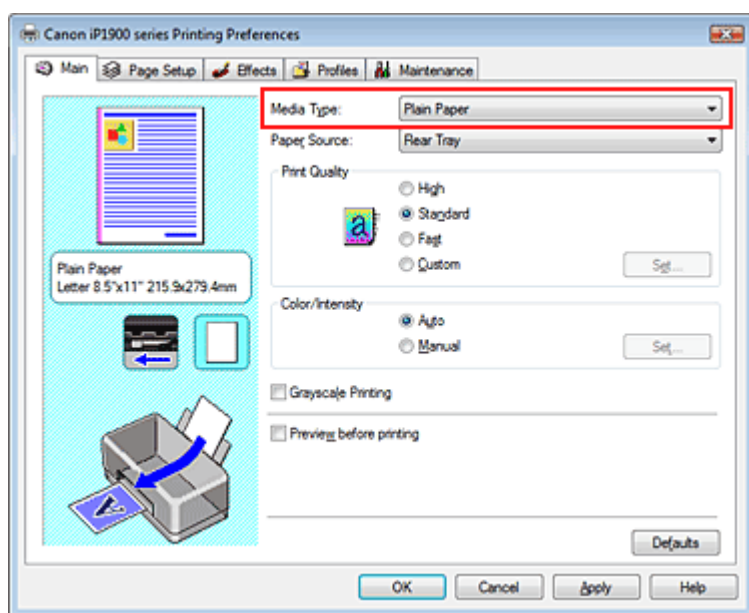

#### 3. Select the print quality

Select High, Standard, or Fast for Print Quality.

#### 4. Select the manual color adjustment

Select Manual for Color/Intensity, and click Set...  
The Manual Color Adjustment dialog box opens.

#### 5. Select color correction

Click Matching tab, and select Driver Matching for Color Correction.

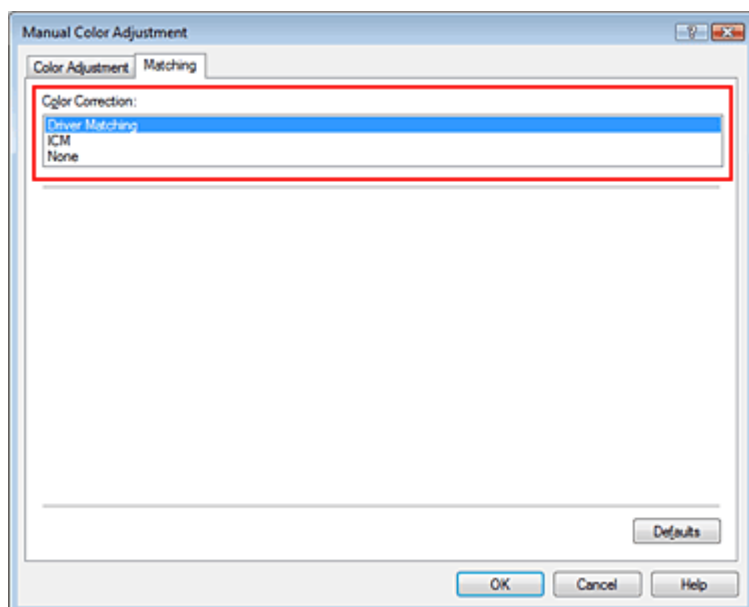

## 6. Set the other items

If necessary, click Color Adjustment tab, and adjust the color balance of Cyan, Magenta, Yellow, and adjust Brightness, Intensity, and Contrast settings, and then click OK.

## 7. Complete the setup

Click OK on the Main tab.

When you execute print, the printer driver adjusts the colors when printing the data.

### Related Topics

- ➔ [Selecting a Combination of the Print Quality Level and a Halftoning Method](#)
- ➔ [Specifying Color Correction](#)
- ➔ [Adjusting Color Balance](#)
- ➔ [Adjusting Brightness](#)
- ➔ [Adjusting Intensity](#)
- ➔ [Adjusting Contrast](#)



## Advanced Guide

Advanced Guide > Printing from a Computer > Printing with Other Application Software > Changing the Print Quality and Correcting Image Data > Specifying Color Correction > Printing with ICC Profiles

### Printing with ICC Profiles

If the image data has a specified ICC profile, you can effectively use the color space (Adobe RGB or sRGB) of the data when printing.

The printer driver setting procedure varies depending on the application software used to print.

#### Printing image data from the application software that can specify an ICC profile

When using Adobe Photoshop, Canon Digital Photo Professional, or any other application software that allows you to specify an ICC profile, you can use the color management system (ICM) found in Windows when printing the data. You can print the editing and touch-up results of an application software by effectively using the color space of the ICC profile specified in the image data.

To use this printing method, you must first use an application software to specify an ICC profile in the image data. For instructions on specifying an ICC profile with an application software program, refer to the manual of the application software you are using.

#### 1. Open the printer driver setup window

#### 2. Select the media type

Select the type of paper loaded in the printer from the Media Type list on the Main tab.

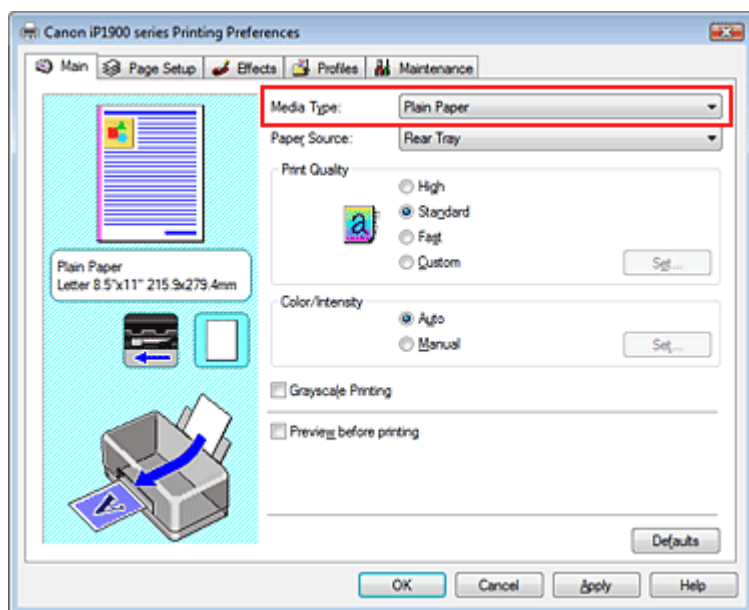

#### 3. Select the print quality

Select High, Standard, or Fast for Print Quality.

#### 4. Select the manual color adjustment

Select Manual for Color/Intensity, and click Set...  
The Manual Color Adjustment dialog box opens.

#### 5. Select color correction

Click Matching tab, and select ICM for Color Correction.

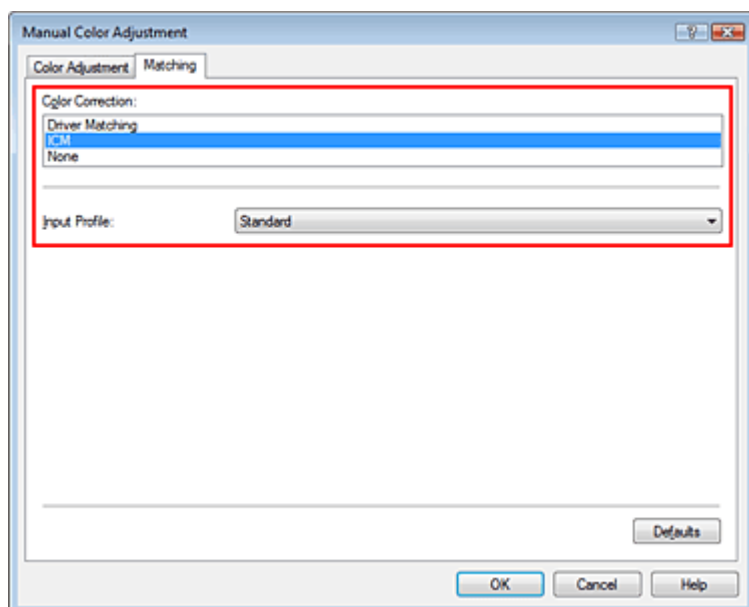

## 6. Set the other items

If necessary, click Color Adjustment tab, and adjust the color balance of Cyan, Magenta, Yellow, and adjust Brightness, Intensity, and Contrast settings, and then click OK.

## 7. Complete the setup

Click OK on the Main tab.

When you execute print, the printer uses the color space of the image data.

### Important

- If you print an image by specifying an individually created profile or a profile for special Canon paper in an application software, select None from the Color Correction menu of the printer driver.

## Printing image data from the application software that cannot specify an ICC profile

When printing from an application software that does not allow you to specify an ICC profile, specify the ICC profile in the print settings of the printer driver and print the data. When printing Adobe RGB data, you can print the data with the Adobe RGB color space even if the application software does not support Adobe RGB.

### 1. Open the printer driver setup window

### 2. Select the media type

Select the type of paper loaded in the printer from the Media Type list on the Main tab.

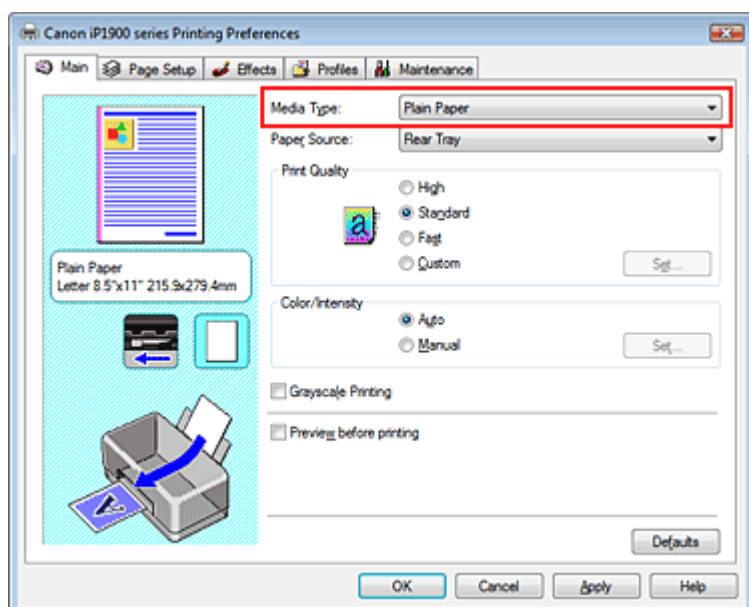

### 3. Select the print quality

Select High, Standard, or Fast for Print Quality.

### 4. Select the manual color adjustment

Select Manual for Color/Intensity, and click Set... Manual Color Adjustment dialog box opens.

### 5. Select color correction

Click Matching tab, and select ICM for Color Correction.

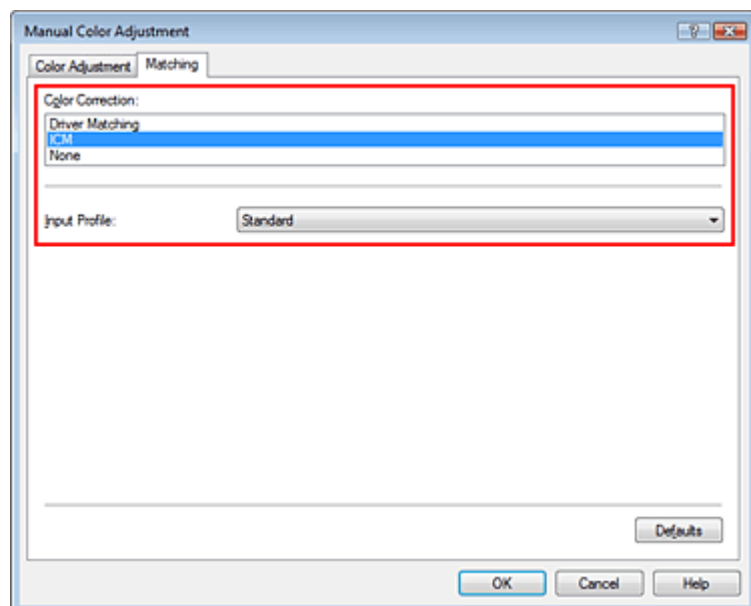

### 6. Select the input profile

Select an Input Profile that matches the color space of the image data.

- **For sRGB data or data without an ICC profile:**

Select Standard.

- **For Adobe RGB data:**

Select Adobe RGB (1998).

#### Important

- If the application software specifies an input profile, the input profile setting of the printer driver becomes invalid.
- If no ICC profiles are installed on your computer, Adobe RGB (1998) is not displayed. You can install ICC profiles from the Setup CD-ROM that accompanies the printer.

### 7. Set the other items

If necessary, click Color Adjustment tab, and adjust the color balance of Cyan, Magenta, Yellow, and adjust Brightness, Intensity, and Contrast settings, and then click OK.

### 8. Complete the setup

Click OK on the Main tab.

When you execute print, the data is printed with the color space of the selected image data.

## Related Topics

- ➔ [Selecting a Combination of the Print Quality Level and a Halftoning Method](#)
- ➔ [Specifying Color Correction](#)
- ➔ [Adjusting Color Balance](#)
- ➔ [Adjusting Brightness](#)
- ➔ [Adjusting Intensity](#)
- ➔ [Adjusting Contrast](#)





[Page top](#) ↑

## Advanced Guide

Advanced Guide > Printing from a Computer > Printing with Other Application Software > Changing the Print Quality and Correcting Image Data > Adjusting Color Balance

### Adjusting Color Balance

You can adjust the color tints during printing.

Since this function adjusts color balance of the output by changing the ink ratios of each color, it changes the total color balance of the document. Use the application software if you want to change the color balance significantly. Use the printer driver only if you want to adjust the color balance slightly.

The following sample shows the case when Color Balance is used to intensify cyan and to diminish yellow so that the overall colors are more uniform.



No adjustment

Adjusted in Color Balance

The procedure for adjusting color balance is as follows:

1. Open the **printer driver setup window**
2. Select the manual color adjustment

On the Main tab, select Manual for Color/Intensity, and click Set....

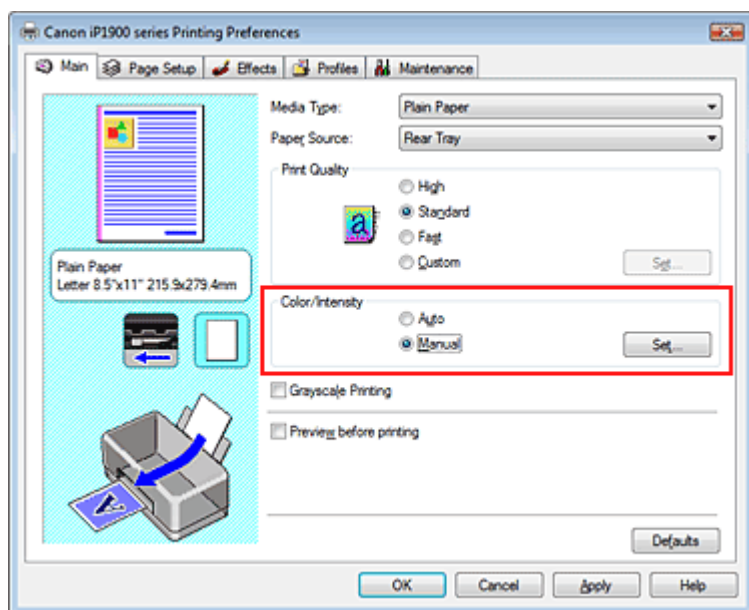

The Manual Color Adjustment dialog box opens.

3. Adjust color balance

There are individual sliders for Cyan, Magenta, and Yellow. Each color becomes stronger when the corresponding slider is moved to the right, and becomes weaker when the corresponding slider is moved to the left. For example, if cyan becomes weaker, the color red becomes stronger.

You can also directly enter a value linked to the slider. Enter a value in the range from -50 to 50.

After adjusting each color, click OK.

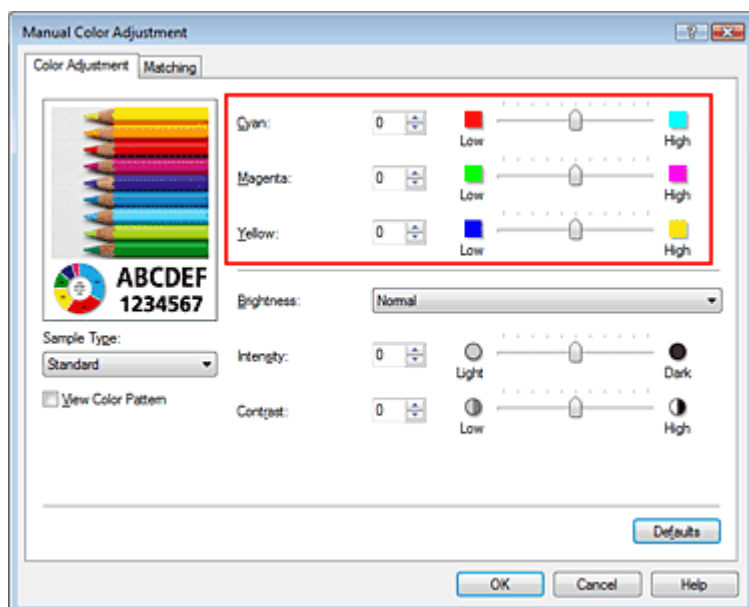

#### 4. Complete the setup

Click OK on the Main tab.

When you execute print, the document is printed with the adjusted color balance.

#### Important

- When the Grayscale Printing check box on the Main tab is checked, Cyan, Magenta, and Yellow appear grayed out and are unavailable.

#### Related Topics

- ➔ [Selecting a Combination of the Print Quality Level and a Halftoning Method](#)
- ➔ [Specifying Color Correction](#)
- ➔ [Adjusting Brightness](#)
- ➔ [Adjusting Intensity](#)
- ➔ [Adjusting Contrast](#)

## Advanced Guide

Advanced Guide > Printing from a Computer > Printing with Other Application Software > Changing the Print Quality and Correcting Image Data > Adjusting Brightness

### Adjusting Brightness

You can change the brightness of the overall image data during printing. This function does not change pure white or pure black but it changes the brightness of the intermediate colors.

The following sample shows the print result when the Brightness specification is changed.



Light is selected

Normal is selected

Dark is selected

The procedure for adjusting brightness is as follows:

1. Open the **printer driver setup window**
2. Select the manual color adjustment

On the Main tab, select Manual for Color/Intensity, and click Set....

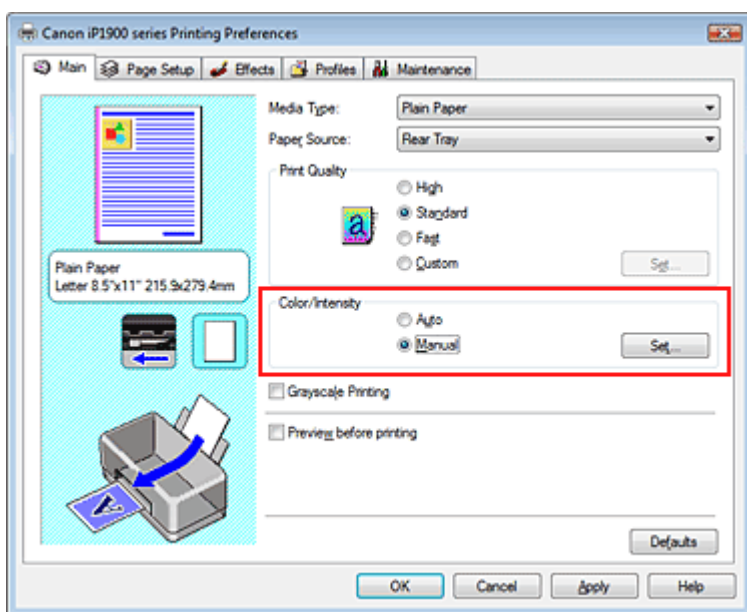

The Manual Color Adjustment dialog box opens.

3. Specify the brightness

Select Light, Normal, or Dark for Brightness, and click OK.

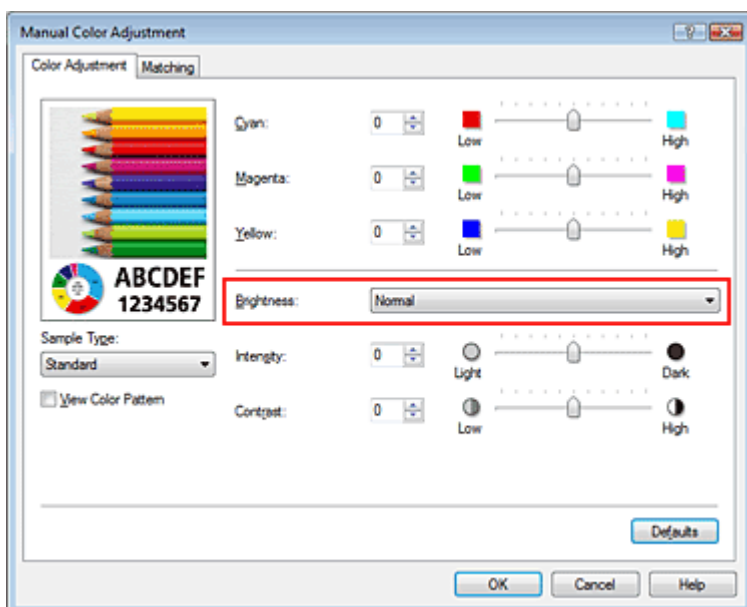

#### 4. Complete the setup

Click OK on the Main tab.

When you execute print, the data is printed at the specified brightness.

#### Related Topics

- ➔ Selecting a Combination of the Print Quality Level and a Halftoning Method
- ➔ Specifying Color Correction
- ➔ Adjusting Color Balance
- ➔ Adjusting Intensity
- ➔ Adjusting Contrast

## Advanced Guide

Advanced Guide > Printing from a Computer > Printing with Other Application Software > Changing the Print Quality and Correcting Image Data > Adjusting Intensity

### Adjusting Intensity

You can dilute (brighten) or intensify (darken) the colors of the overall image data during printing.

If you want to sharpen the print results, you should intensify the colors.

The following sample shows the case when the intensity is increased so that all colors become more intense when the image data is printed.

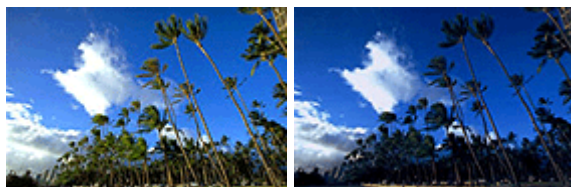

No adjustment

Higher Intensity

The procedure for adjusting intensity is as follows:

1. Open the **printer driver setup window**

2. Select the manual color adjustment

Select Manual for Color/Intensity on the Main tab, and click Set....

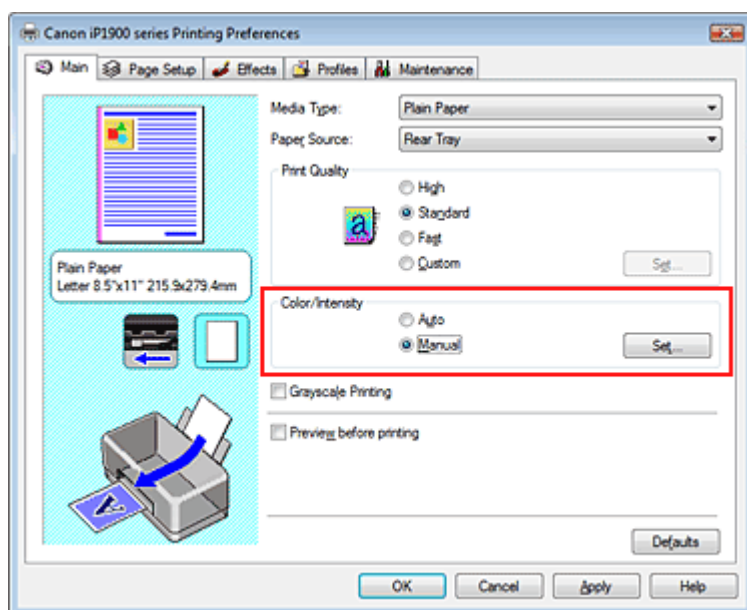

The Manual Color Adjustment dialog box opens.

3. Adjust intensity

Moving the Intensity slider to the right intensifies (darkens) the colors. Moving the slider to the left dilutes (brightens) the colors.

You can also directly enter a value linked to the slider. Enter a value in the range from -50 to 50.

After adjusting each color, click OK.

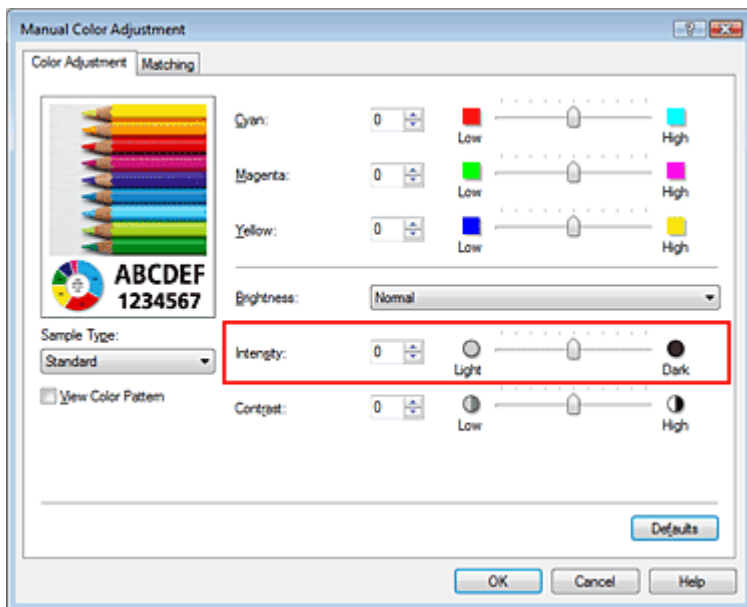

### Important

- Adjust the slider gradually.

#### 4. Complete the setup

Click OK on the Main tab.

When you execute print, the image data is printed with the adjusted intensity.

#### Related Topics

- ➔ [Selecting a Combination of the Print Quality Level and a Halftoning Method](#)
- ➔ [Specifying Color Correction](#)
- ➔ [Adjusting Color Balance](#)
- ➔ [Adjusting Brightness](#)
- ➔ [Adjusting Contrast](#)

## Advanced Guide

Advanced Guide > Printing from a Computer > Printing with Other Application Software > Changing the Print Quality and Correcting Image Data > Adjusting Contrast

### Adjusting Contrast

You can adjust the image contrast during printing.

To make the differences between the light and dark portions of images greater and more distinct, increase the contrast. On the other hand, to make the differences between the light and dark portions of images smaller and less distinct, reduce the contrast.

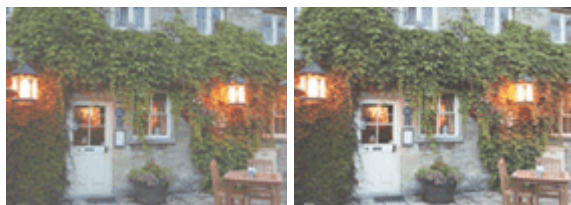

No adjustment

Adjust the contrast

The procedure for adjusting contrast is as follows:

1. Open the **printer driver setup window**
2. Select the manual color adjustment

On the Main tab, select Manual for Color/Intensity, and click Set....

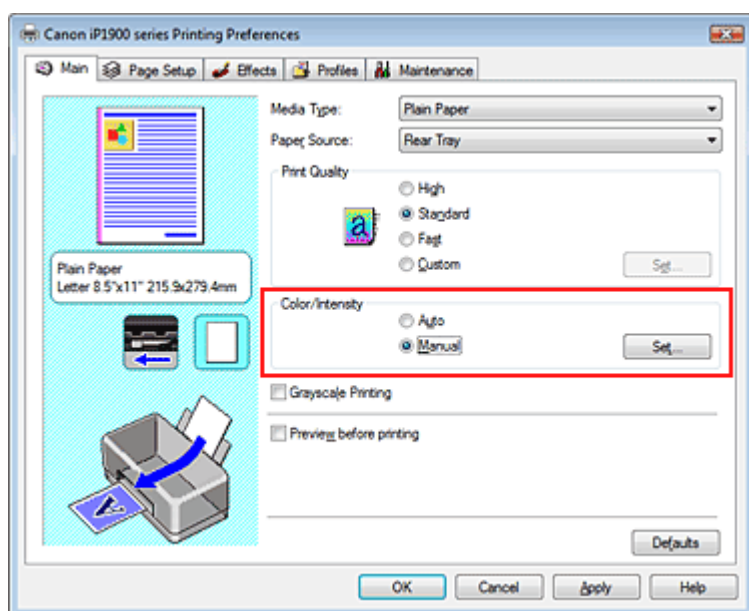

The Manual Color Adjustment dialog box opens.

3. Adjust the contrast

Moving the Contrast slider to the right increases the contrast, and moving it to the left decreases the contrast.

You can also directly enter a value linked to the slider. Enter a value in the range from -50 to 50.

After adjusting each color, click OK.



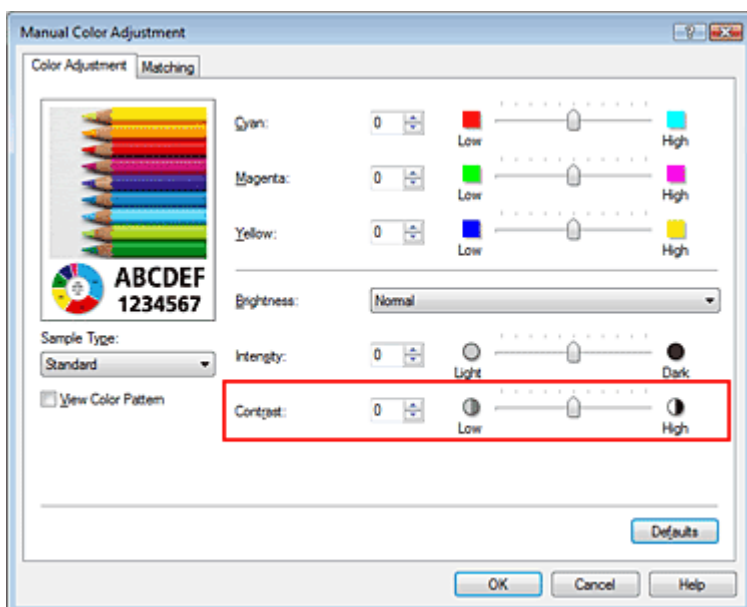

#### 4. Complete the setup

Click OK on the Main tab.

When you execute print, the image is printed with the adjusted contrast.

#### Related Topics

- ➔ Selecting a Combination of the Print Quality Level and a Halftoning Method
- ➔ Specifying Color Correction
- ➔ Adjusting Color Balance
- ➔ Adjusting Brightness
- ➔ Adjusting Intensity

## Advanced Guide

Advanced Guide > Printing from a Computer > Printing with Other Application Software > Changing the Print Quality and Correcting Image Data > Simulating an Illustration

### Simulating an Illustration

With the Simulate Illustration function, you can print full-color or 256-color image data so that it looks like a hand-drawn illustration. You can add different effects to the original profile and colors.



The procedure for performing Simulate Illustration is as follows:

1. Open the **printer driver setup window**
2. Set the Simulate Illustration

Check the Simulate Illustration check box on the Effects tab, and adjust the Contrast as necessary. Moving the slider to the right lightens the image data and moving the slider to the left darkens the image data.

The current settings are displayed in the Settings Preview on the left side of the printer driver.

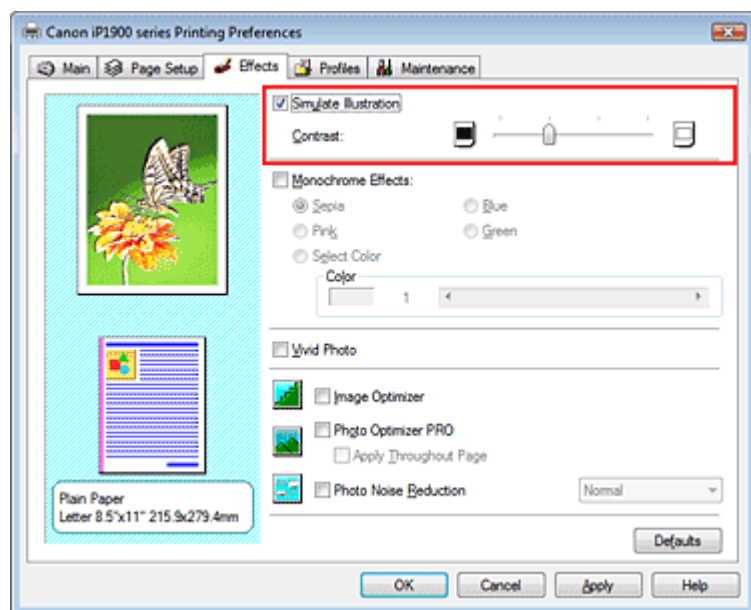

3. Complete the setup

Click OK.

When you execute print, the image will be printed so that it looks hand-drawn.

## Advanced Guide

Advanced Guide > Printing from a Computer > Printing with Other Application Software > Changing the Print Quality and Correcting Image Data > Representing Image Data with a Single Color

# Representing Image Data with a Single Color

With the Monochrome Effects function, you can benefit from coloring effects such as changing a photograph to a sepia tone image.

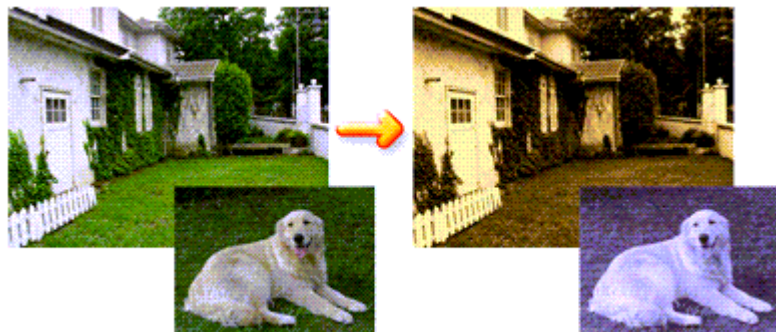

The procedure for performing Monochrome Effects is as follows:

1. Open the **printer driver setup window**
2. Set Monochrome Effects

Check the Monochrome Effects check box on the Effects tab and select your desired color.

If you use Select Color, move the Color slider to specify the color you want.

The current settings are displayed in the Settings Preview on the left side of the printer driver.

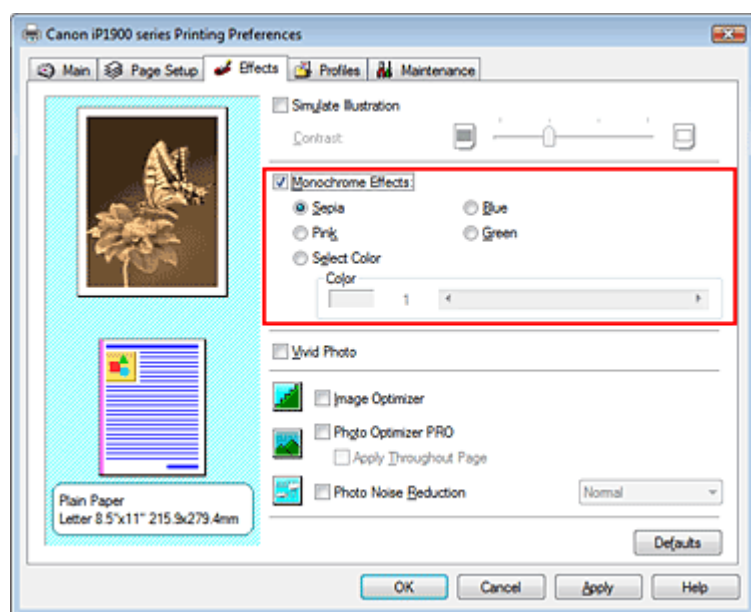

3. Complete the setup

Click OK.

When you execute print, the image will be printed with a single color.

### Important

- When the Grayscale Printing check box on the Main tab is checked, Monochrome Effects appears grayed out and is unavailable.

## Advanced Guide

Advanced Guide > Printing from a Computer > Printing with Other Application Software > Changing the Print Quality and Correcting Image Data > Presenting Image Data with Vivid Colors

### Presenting Image Data with Vivid Colors

The Vivid Photo function allows you to print image data with vivid colors. The notable feature of Vivid Photo is that it emphasizes the colors in background sceneries while maintaining the human skin color natural. By using this function, you can make vivid hues appear even more vivid.

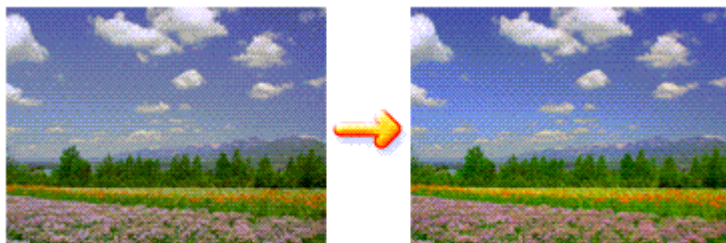

The procedure for performing Vivid Photo is as follows:

1. Open the **printer driver setup window**
2. Set Vivid Photo

Check the Vivid Photo check box on the Effects tab.

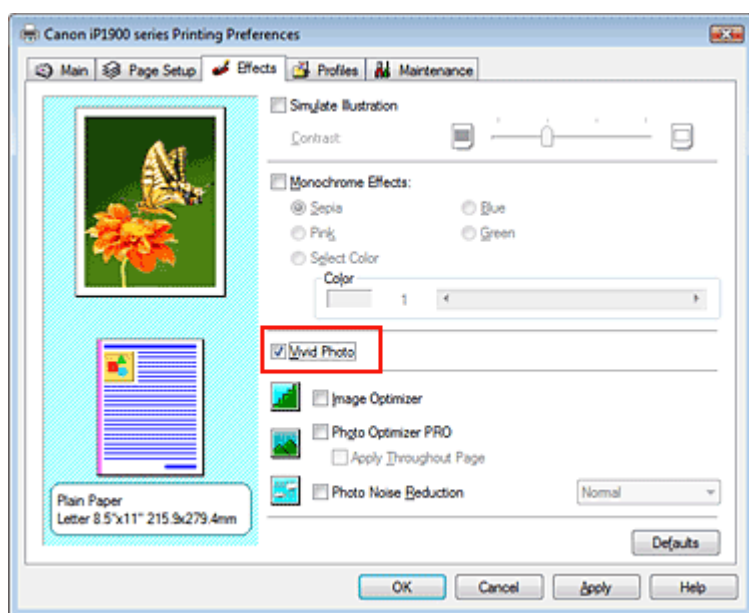

3. Complete the setup

Click OK.

When you execute print, the image will be printed with vivid colors.

## Advanced Guide

Advanced Guide > Printing from a Computer > Printing with Other Application Software > Changing the Print Quality and Correcting Image Data > Smoothing Jagged Outlines

### Smoothing Jagged Outlines

The Image Optimizer function allows you to smooth jagged outlines in photos and graphics that have been enlarged with your application. This feature is especially useful when printing low-resolution images from Web pages.

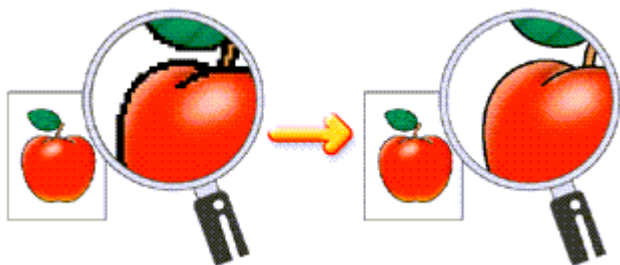

The procedure for performing Image Optimizer is as follows:

1. Open the [printer driver setup window](#)
2. Perform Image Optimizer

Check the Image Optimizer check box on the Effects tab.

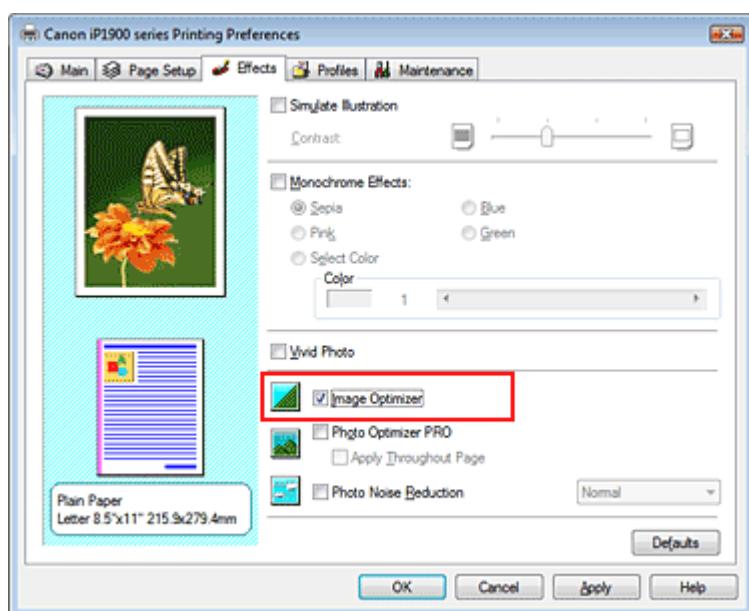

3. Complete the setup

Click OK.

The photos and graphics will be printed with jagged outlines smoothed.

#### Note

- Depending on application software or resolution of image data, the Image Optimizer may have no discernible effects.
- It may take longer to complete printing if the Image Optimizer is used.

## Advanced Guide

Advanced Guide > Printing from a Computer > Printing with Other Application Software > Changing the Print Quality and Correcting Image Data > Changing Color Properties to Improve Coloration

## Changing Color Properties to Improve Coloration

The Photo Optimizer PRO function corrects colors of digital camera images or scanned images. It is specially designed to compensate for color shift, overexposure, and underexposure.

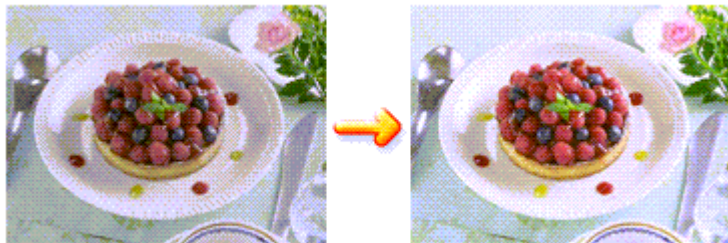

The procedure for performing Photo Optimizer PRO is as follows:

1. Open the printer driver setup window
2. Set the Auto Photo mode

Check the Photo Optimizer PRO check box on the Effects tab.

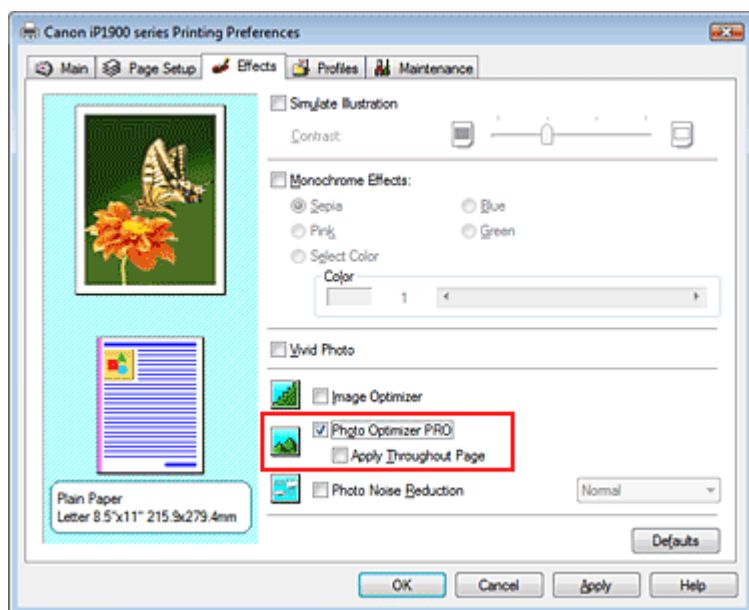

Normally there is no need to check the Apply Throughout Page check box. Images within each page are optimized on an image-by-image basis.

### Note

- Check the Apply Throughout Page check box when printing image data that has been processed, such as being cropped or rotated. In this case the entire page will be treated as a single image to be optimized.

3. Complete the setup

Click OK.

When you execute print, the images will be printed with color compensation.

### Important

- Photo Optimizer PRO does not function when:
  - Background is set in the Stamp/Background dialog box on the Page Setup tab.
  - Define Stamp... is selected in the Stamp/Background dialog box on the Page Setup tab, and the bitmapped stamp is configured.

 **Note**

---

- Depending on images, the Photo Optimizer PRO may have no discernible effect.
- 

[Page top](#) ↑

## Advanced Guide

Advanced Guide > Printing from a Computer > Printing with Other Application Software > Changing the Print Quality and Correcting Image Data > Reducing Photo Noise

## Reducing Photo Noise

With the Photo Noise Reduction function, you can reduce the digital camera noise and improve the image quality of the digital print.

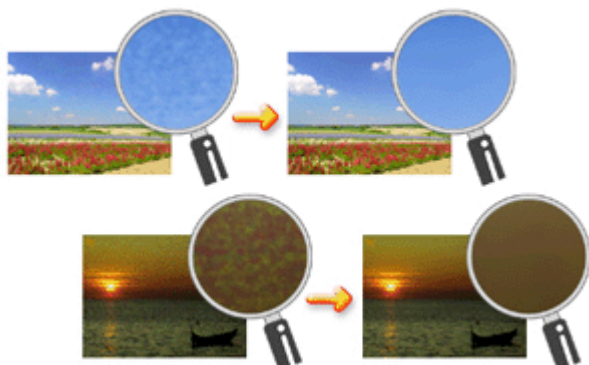

The procedure for performing Photo Noise Reduction is as follows:

1. Open the [printer driver setup window](#)
2. Set Photo Noise Reduction

Check the Photo Noise Reduction check box on the Effects tab and select Normal or Strong for the level.

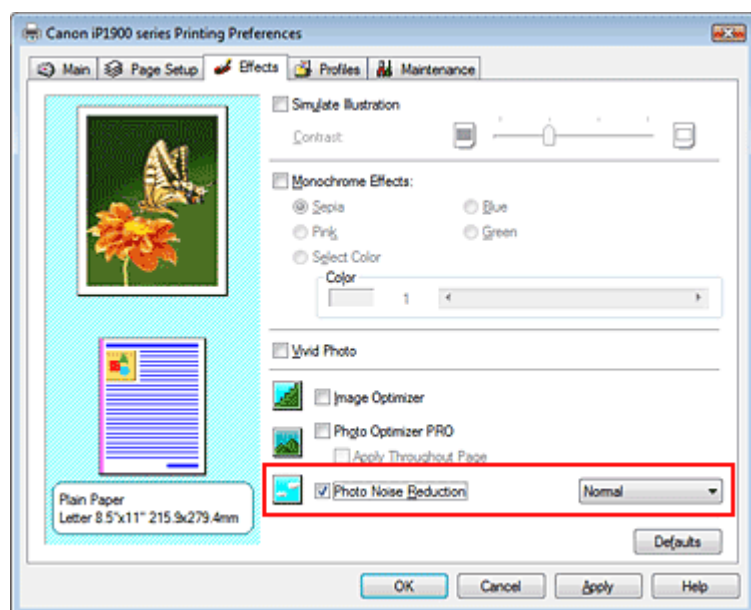

3. Complete the setup

Click OK.

When you execute print, the image will be printed with the digital camera noise being reduced.

### Note

- It is recommended to select Normal for most cases. Select Strong if you have selected Normal and the noise still bothers you.
- Depending on application software or resolution of image data, effects of digital camera noise reduction may not be obvious.
- When this function is used for other than photos taken by digital cameras, image may be distorted.



## Advanced Guide

[Advanced Guide](#) > [Printing from a Computer](#) > [Printing with Other Application Software](#) > [Overview of the Printer Driver](#)  
> [Overview of the Printer Driver](#)

---

### Overview of the Printer Driver

- ➔ [Canon IJ Printer Driver](#)
- ➔ [How to Open the Printer Driver Setup Window](#)
- ➔ [Maintenance Tab](#)
- ➔ [Canon IJ Status Monitor](#)
- ➔ [The Canon IJ Preview](#)

[Page top](#) ↕

## Advanced Guide

[Advanced Guide](#) > [Printing from a Computer](#) > [Printing with Other Application Software](#) > [Overview of the Printer Driver](#)  
> [Canon IJ Printer Driver](#)

# Canon IJ Printer Driver

The Canon IJ printer driver is software that is installed on your computer for printing data on this printer.

The Canon IJ printer driver converts the print data created by your Windows application into data that your printer can understand and sends the converted data to the printer.

Because the format of print data varies depending on the your model, you need to have a Canon IJ printer driver for the specific model you are using.

## How to Use Help

You can display the Help describing the driver setting items through the Printing Preferences screen of the Canon IJ printer driver.

- **To view all descriptions of a tab...**

Click the Help button on each tab.

A description for each item on the tab appears.

You can also display a description for a dialog box by clicking the link that appears on the corresponding tab.

- **To see a description for each item...**

Right-click the item you want to learn about and then click the Help button.

Alternatively, click  [Help] button at the right end of the title bar and then click the item you want to learn about.

A description of the item is displayed.

## Related Topic

[How to Open the Printer Driver Setup Window](#)



[Page top](#) ↑

## Advanced Guide

Advanced Guide > Printing from a Computer > Printing with Other Application Software > Overview of the Printer Driver > Canon IJ Printer Driver > How to Open the Printer Driver Setup Window

# How to Open the Printer Driver Setup Window

The printer driver setup window can be displayed through the application software in use or the Start menu of the Windows.

### Note

- This guide mainly describes operations on the Windows Vista. Operations may differ depending on versions of the Windows.

## Open the Printer Driver Setup Window through the Application Software

Follow the procedure below to configure print settings when printing.

### 1. Select the command you perform printing on the application software in use

In general, select Print on the File menu to open the Print dialog box.

### 2. Select your model name and click Preferences (or Properties)

The printer driver setup window appears.

### Note

- Depending on application software you use, command names or menu names may vary and there may be more steps. For details, refer to the user's manual of your application software.

## Open the Printer Driver Setup Window through the Start Menu

Follow the procedure below to perform maintenance operations such as print head cleaning, or to configure print settings that are common for all application software.

### 1. Select items from the Start menu as shown below:

- In Windows Vista, select the Start menu -> Control Panel -> Hardware and Sound -> Printers.
- In Windows XP, select the Start menu -> Control Panel -> Printers and Other Hardware -> Printers and Faxes.
- In Windows 2000, select the Start menu -> Settings -> Printers.

### 2. Right-click your model name icon, and then select Printing Preferences from the displayed menu.

The printer driver setup window appears.

### Important

- Opening the printer driver setup window through Properties displays such tabs regarding the Windows functions as the Ports (or Advanced) tab. Those tabs do not appear when opening through Printing Preferences or application software. About tabs regarding Windows functions, refer to the user's manual for the Windows.



## Advanced Guide

Advanced Guide > Printing from a Computer > Printing with Other Application Software > Overview of the Printer Driver > Canon IJ Printer Driver > Maintenance Tab

## Maintenance Tab

The Maintenance tab allows you to perform printer maintenance or change the settings of the printer.

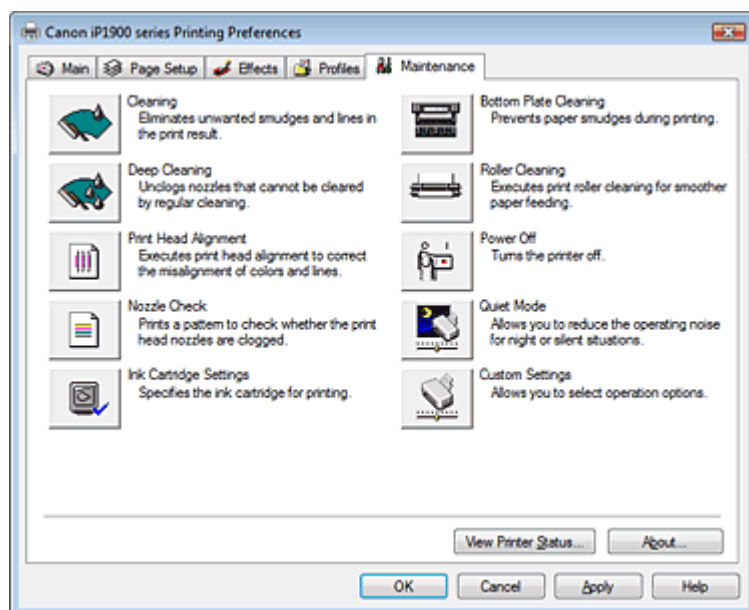

### Features

- ➔ Cleaning the Print Heads
- ➔ Cleaning the Paper Feed Rollers
- ➔ Aligning the Print Head Position
- ➔ Checking the Print Head Nozzles
- ➔ Cleaning Inside the Printer
- ➔ Setting the Ink Cartridge
- ➔ Managing the Printer Power

### Related features

- ➔ Reducing the Printer Noise/Quiet Mode
- ➔ Changing the Printer Operation Mode



## Advanced Guide

Advanced Guide > Printing from a Computer > Printing with Other Application Software > Overview of the Printer Driver > Canon IJ Status Monitor

### Canon IJ Status Monitor

The Canon IJ Status Monitor is an application software that shows the status of the printer and the progress of printing on the Windows screen. You will know the status of the printer with graphics, icons, and messages.

#### Launching the Canon IJ Status Monitor

The Canon IJ Status Monitor launches automatically when data is sent to the printer. When launched, the Canon IJ Status Monitor appears as a button on the Task Bar.



Click the Status Monitor button displayed on the Task Bar. The Canon IJ Status Monitor appears.

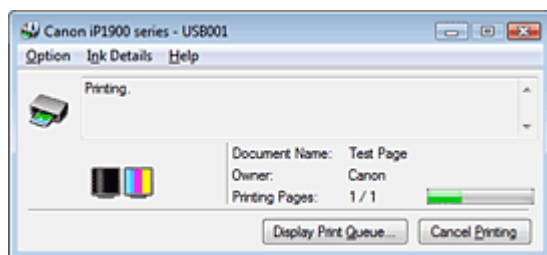

#### Note

- To open the Canon IJ Status Monitor when the printer is not printing, open the [printer driver setup window](#) and click View Printer Status... on the Maintenance tab.

#### When Errors Occur

The Canon IJ Status Monitor is automatically displayed when an error occurs (e.g., if the printer runs out of paper or if the ink is low).

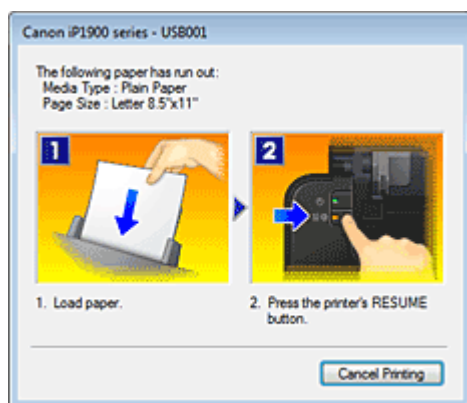

In such cases, take the appropriate action as described.

## Advanced Guide

[Advanced Guide](#) > [Printing from a Computer](#) > [Printing with Other Application Software](#) > [Overview of the Printer Driver](#)  
> [The Canon IJ Preview](#)

---

### The Canon IJ Preview

The Canon IJ Preview is an application software that displays what the print result will look like before a document is actually printed.

The preview reflects the information that is set within the printer driver and allows you to check the document layout, print sequence, and number of pages. You can also change the media type settings.

If you want to display a preview before printing, open the [printer driver setup window](#), click the Main tab, and check the Preview before printing check box.

If you do not want to display a preview before printing, uncheck the check box.

#### Related Topic

➡ [Displaying the Print Results before Printing](#)

[Page top](#) ↑

## Advanced Guide

Advanced Guide > Maintenance

---

### Maintenance

- ➔ [Cleaning Your Printer](#)
- ➔ [Performing Maintenance from a Computer](#)

[Page top](#) ↑

## Advanced Guide

[Advanced Guide](#) > [Maintenance](#) > [Cleaning Your Printer](#)

---

# Cleaning Your Printer

- ➔ [Cleaning](#)
- ➔ [Cleaning the Exterior of the Printer](#)
- ➔ [Cleaning the Protrusions Inside the Printer](#)

[Page top](#) ↕



## Advanced Guide

[Advanced Guide](#) > [Maintenance](#) > [Cleaning Your Printer](#) > [Cleaning](#)

---

# Cleaning

This section describes the cleaning procedure that is needed to maintain your printer.

### **caution**

- Do not use tissue paper, paper towels, rough-textured cloth, or similar materials for cleaning so as not to scratch the surface. Paper tissue powder or fine threads may remain inside the printer and cause problems such as Print Head blockage and poor printing results. Be sure to use a soft cloth.
  - Never use volatile liquids such as thinners, benzene, acetone, or any other chemical cleaner to clean the printer, as this may cause a malfunction or damage the printer's surface.
- 

➔ [Cleaning the Exterior of the Printer](#)

➔ [Cleaning the Protrusions Inside the Printer](#)

[Page top](#) ↑

## Advanced Guide

[Advanced Guide](#) > [Maintenance](#) > [Cleaning Your Printer](#) > [Cleaning the Exterior of the Printer](#)

---

### Cleaning the Exterior of the Printer

Be sure to use a soft cloth such as eyeglasses cleaning cloth and wipe off dirt on the surface gently. Smooth out wrinkles on the cloth if necessary before cleaning.

#### **caution**

- Be sure to turn off the power and disconnect the power plug before cleaning the printer.
  - Do not use tissue paper, paper towels, rough-textured cloth, or similar materials, as this may scratch the surface.
- 

[Page top](#) ↕

## Advanced Guide

Advanced Guide > Maintenance > Cleaning Your Printer > Cleaning the Protrusions Inside the Printer

### Cleaning the Protrusions Inside the Printer

If protrusions inside the printer are stained, wipe off any ink from the protrusions using a cotton swab or the like.

#### **caution**

- Be sure to turn off the power and disconnect the power plug before cleaning the printer.

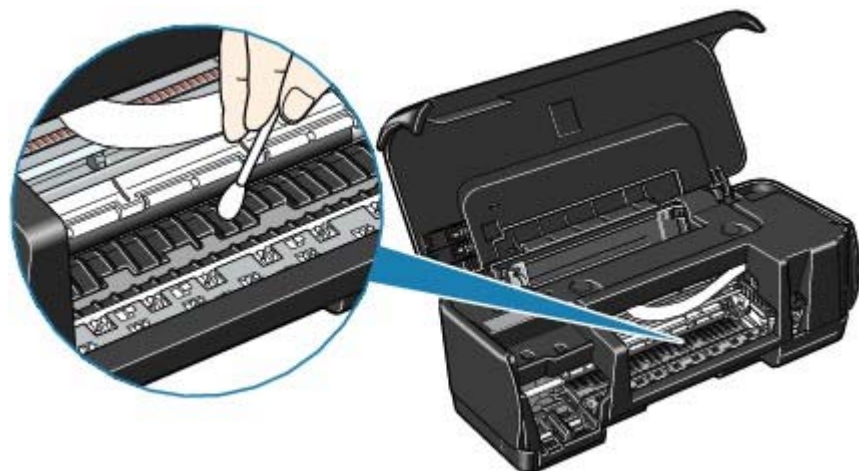

[Page top](#) 

## Advanced Guide

Advanced Guide > Maintenance > Performing Maintenance from a Computer

---

### Performing Maintenance from a Computer

- ➔ [Cleaning the Print Heads](#)
- ➔ [Cleaning the Paper Feed Rollers](#)
- ➔ [Aligning the Print Head Position](#)
- ➔ [Checking the Print Head Nozzles](#)
- ➔ [Cleaning Inside the Printer](#)

[Page top](#) ↕

## Advanced Guide

Advanced Guide > Maintenance > Performing Maintenance from a Computer > Cleaning the Print Heads

### Cleaning the Print Heads

The print head cleaning function allows you to remove any blockages in the print head nozzles. Perform print head cleaning if printing is faint or a specific color fails to print, even though there is enough ink.

The procedure for cleaning the print heads is as follows:



#### Cleaning

1. Open the [printer driver setup window](#)
2. Make sure that the printer is on and then click Cleaning on the Maintenance tab  
Print head cleaning starts.
3. Complete cleaning  
Click OK when the confirmation message appears.  
Next, the Nozzle Check dialog box opens.
4. Check the results  
To check whether the print quality has improved, click Print Check Pattern. To cancel the check process, click Cancel.  
If cleaning the head once does not resolve the print head problem, clean it once more.



#### Deep Cleaning

Deep Cleaning is more thorough than Cleaning. Perform deep cleaning when two cleaning attempts do not resolve the print head problem.

1. Open the [printer driver setup window](#)
2. Click Deep Cleaning on the Maintenance tab  
The Deep Cleaning dialog box opens. Follow the instruction shown in the dialog box.  
Click Initial Check Items to display the items you need to check before performing Deep Cleaning.
3. Make sure that the printer is on and then click Execute.  
Click OK when the confirmation message appears.  
Print head deep cleaning starts.

#### Important

- Cleaning consumes a small amount of ink. Deep Cleaning consumes a larger amount of ink than Cleaning.  
Cleaning the print heads frequently will rapidly deplete your printer's ink supply. Consequently, perform cleaning only when necessary.

#### Note

- If there is no sign of improvement after Deep Cleaning, switch off the printer and perform again. If there is still no sign of improvement, the ink may have run out. For details on the remedial action to be taken, see "Machine Moves But Ink Is Not Ejected."

**Related Topic**

➡ [Checking the Print Head Nozzles](#)

[Page top](#) ↑

## Advanced Guide

[Advanced Guide](#) > [Maintenance](#) > [Performing Maintenance from a Computer](#) > [Cleaning the Paper Feed Rollers](#)

### Cleaning the Paper Feed Rollers

The feed roller cleaning function allows you to clean the paper feed roller. Perform feed roller cleaning when there are paper particles sticking to the paper feed roller and paper is not fed properly.

The procedure for cleaning the feed rollers is as follows:



#### Roller cleaning

**1.** Prepare the printer

Remove all sheets of paper from the rear tray.

**2.** Open the [printer driver setup window](#)

**3.** Click Roller Cleaning on the Maintenance tab

The confirmation message appears.

**4.** Execute paper feed roller cleaning

Make sure that the printer is on and click OK.

Paper feed roller cleaning starts.

**5.** Complete paper feed roller cleaning

After the rollers have stopped, follow the instruction in the message, load three sheets of plain paper into the rear tray, and click OK.

Paper will be ejected and feed roller cleaning will be completed.

## Advanced Guide

Advanced Guide > Maintenance > Performing Maintenance from a Computer > Aligning the Print Head Position

# Aligning the Print Head Position

Print head alignment corrects the installation positions of the print head and improves deviated colors and lines.

The procedure for performing print head alignment is as follows:



### Print Head Alignment

1. Open the [printer driver setup window](#)
2. Click Print Head Alignment on the Maintenance tab  
A message appears.
3. Load paper in the printer  
Set the paper thickness lever to the left, and load a sheet of A4 size or Letter size plain paper into the rear tray.
4. Execute head alignment  
Follow the instruction in the message.  
The Print Head Alignment dialog box opens.
5. Check the printed pattern  
Enter the numbers of the patterns with the least amount of streaks in the associated boxes.  
Clicking the patterns with the least amount of streaks in the preview window, will automatically set their numbers in the associated boxes.  
When you have entered all the necessary values, click OK.



- If you look at the print results and still cannot determine which pattern is the one with the least amount of streaks, see your printer manual.



## Advanced Guide

Advanced Guide > Maintenance > Performing Maintenance from a Computer > Checking the Print Head Nozzles

### Checking the Print Head Nozzles

The nozzle check function allows you to check whether the print heads are working properly by printing a nozzle check pattern. Print the pattern if printing becomes faint, or if a specific color fails to print.

The procedure for printing a nozzle check pattern is as follows:



#### Nozzle Check

1. Open the [printer driver setup window](#)

2. Click Nozzle Check on the Maintenance tab

The Nozzle Check dialog box opens.

To display a list of items that you should check before printing the check pattern, click Initial Check Items.

3. Load paper in the printer

Set the paper thickness lever to the left, and load a sheet of A4 size or Letter size plain paper into the rear tray.

4. Print a nozzle check pattern

Make sure that the printer is on and click Print Check Pattern.

The nozzle check pattern is printed.

Click OK when the confirmation message appears.

The Pattern Check dialog box opens.

5. Check the print result

Check the print result. If the print result is normal, click Exit.

If the print result is smudged or if there are any unprinted sections, click Cleaning to clean the print head.

#### Related Topic

➔ [Cleaning the Print Heads](#)

[Page top](#) ↑

## Advanced Guide

[Advanced Guide](#) > [Maintenance](#) > [Performing Maintenance from a Computer](#) > [Cleaning Inside the Printer](#)

### Cleaning Inside the Printer

The bottom plate cleaning function allows you to prevent smudges on the reverse side of a sheet of paper. Perform bottom plate cleaning before you perform duplex printing. Also perform bottom plate cleaning if ink smudges caused by something other than print data appear on the printed page.

The procedure for performing bottom plate cleaning is as follows:



#### Bottom Plate Cleaning

1. Open the [printer driver setup window](#)
2. Click Bottom Plate Cleaning on the Maintenance tab

The Bottom Plate Cleaning dialog box opens.

3. Load paper in the printer

As instructed in the dialog box, fold the A4 size or Letter size plain paper in half horizontally, and then unfold the sheet.

Load the paper into the rear tray in the portrait orientation with the crest of the crease facing down.

4. Perform the bottom plate cleaning

Make sure that the printer is on and click Execute. Bottom plate cleaning starts.

[Page top](#) ↑

## Advanced Guide

Advanced Guide > Changing the Printer Settings

---

# Changing the Printer Settings

➔ [Changing Printer Settings from Your Computer](#)

[Page top](#) ↕

## Advanced Guide

[Advanced Guide](#) > [Changing the Printer Settings](#) > [Changing Printer Settings from Your Computer](#)

---

# Changing Printer Settings from Your Computer

- ➔ [Changing the Print Options](#)
- ➔ [Saving a Changed Printing Profile](#)
- ➔ [Setting the Ink Cartridge](#)
- ➔ [Managing the Printer Power](#)
- ➔ [Reducing the Printer Noise](#)
- ➔ [Changing the Printer Operation Mode](#)

[Page top](#) ↑

## Advanced Guide

Advanced Guide > Changing the Printer Settings > Changing Printer Settings from Your Computer > Changing the Print Options

### Changing the Print Options

You change detailed print driver settings for print data that is sent from an application software. Specify this option if you encounter print failures such as part of an image data being cut off.

The procedure for changing the print options is as follows:

1. Open the [printer driver setup window](#)
2. Click Print Options... on the Page Setup tab

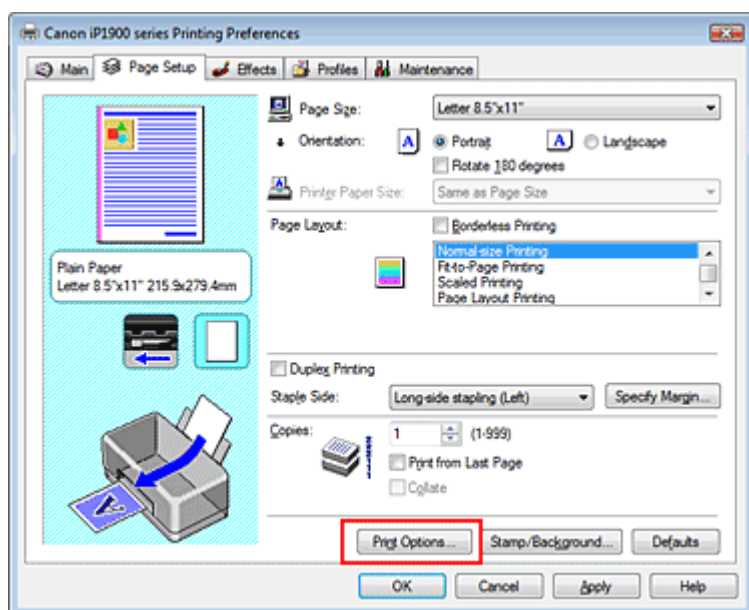

The Print Options dialog box opens.

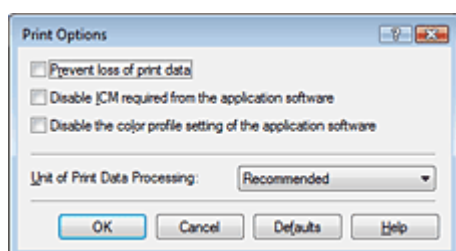

3. Change the individual settings

If necessary, change the setting of each item, and then click OK.

The Page Setup tab is displayed again.

## Advanced Guide

Advanced Guide > Changing the Printer Settings > Changing Printer Settings from Your Computer > Saving a Changed Printing Profile

### Saving a Changed Printing Profile

You can assign a name to the settings made on the Main, Page Setup, and Effects tabs and save them as a printing profile. The saved printing profile can be retrieved and used from the Profiles tab at any time. Unnecessary printing profiles can be deleted at any time.

The procedure for registering a printing profile is as follows:

#### Registering a printing profile

##### 1. Open the printer driver setup window

##### 2. Set the necessary items

Make your desired settings on the Main, Page Setup, and Effects tabs.

##### 3. On the Profiles tab, click Add to Profiles...

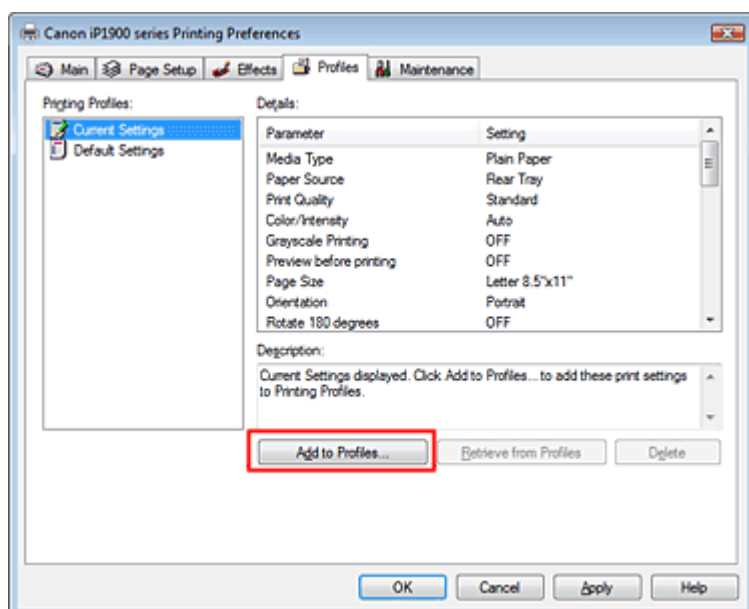

The Add to Profiles dialog box opens.

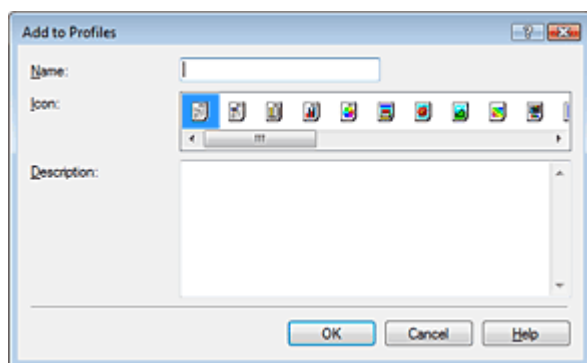

##### 4. Save the settings

Set Name, Icon, and Description, then click OK.

The profile is saved and the Profiles tab is displayed again.

The name and icon are added to the Printing Profiles list.

#### Note

- If you install the printer driver again or upgrade the version of the printer driver, the print settings you

registered will be deleted from Printing Profiles.

Registered print settings cannot be saved and preserved. In this case, register the print settings again.

---

### Using registered print settings

#### 1. Select the print settings to be used

Select a printing profile in the Printing Profiles list on the Profiles tab.

The parameters and settings of the profile are displayed in the Details box.

#### 2. Retrieve from Profiles

Click Retrieve from Profiles.

Click OK when a message appears.

Settings of the selected profile are applied to the Main, Page Setup, and Effects tabs.



#### Note

- If you want to revert a profile to the default settings, select Default Settings in the Printing Profiles list and click Retrieve from Profiles.
- 

### Deleting unnecessary printing profile

#### 1. Select the printing profile to be deleted

Select the printing profile you want to delete from the Printing Profiles list on the Profiles tab.

#### 2. Delete the printing profile

Click Delete. When the confirmation message appears, click OK.

The selected printing profile is deleted from the Printing Profiles list.



#### Note

- Current Settings and Default Settings cannot be deleted.
-

## Advanced Guide

[Advanced Guide](#) > [Changing the Printer Settings](#) > [Changing Printer Settings from Your Computer](#) > [Setting the Ink Cartridge](#)

### Setting the Ink Cartridge

When printing, you can specify the ink cartridge you use.

If one of the ink cartridges becomes empty, you can continue printing by specifying the ink cartridge that still has ink.

The procedure for specifying the ink cartridge is as follows:



#### Ink Cartridge Settings

1. Open the [printer driver setup window](#)
2. Click Ink Cartridge Settings on the Maintenance tab

The Ink Cartridge Settings dialog box appears.

3. Select the ink cartridge to be used

Select the ink cartridge to be used for printing and click OK.

The specified ink cartridge will be used from the next printing.

#### Important

- When the following settings are configured, Black Only is disabled. The color ink cartridge is also used to print.
  - A media type other than Plain Paper, Hagaki, or Envelope is selected for Media Type on the Main tab.
  - Borderless Printing is checked on the Page Setup tab.
- Canon recommends that you use the ink cartridges installed in the printer and not remove them until the ink runs out.

[Page top](#) ↑



## Advanced Guide

[Advanced Guide](#) > [Changing the Printer Settings](#) > [Changing Printer Settings from Your Computer](#) > [Managing the Printer Power](#)

# Managing the Printer Power

This function allows you to manage the printer power from the printer driver.

The procedure for managing the printer power is as follows:



### Power Off

The Power Off function turns off the printer. If you use this function, you will not be able to turn the printer on from the printer driver.

1. Open the [printer driver setup window](#)
2. Execute power off

Click Power Off on the Maintenance tab. When the confirmation message appears, click OK.

The printer power switches off, and the Maintenance tab is displayed again.

[Page top](#) ↑

## Advanced Guide

Advanced Guide > Changing the Printer Settings > Changing Printer Settings from Your Computer > Reducing the Printer Noise

# Reducing the Printer Noise

This function allows you to reduce the operating noise of the printer. Select if you wish to reduce the operating noise of the printer at night, etc.  
Using this function may lower the print speed.

The procedure for changing the quiet mode settings is as follows:



## Quiet Mode

1. Open the [printer driver setup window](#)
2. Click Quiet Mode on the Maintenance tab

The Quiet Mode dialog box opens.

3. Set the silent function

If necessary, specify one of the following items:

### Do not use quiet mode

The operating noise of the printer is at normal volume.

### Always use quiet mode

Select this option when you wish to reduce the operating noise of the printer.

### Use quiet mode within specified time

The operating noise of the printer can be reduced during a specified period of time.  
Set the Start time and End time when you wish the quiet mode to be activated.

### Important

- The time specified in Start time and in End time must be different.

4. Transmit the settings

Make sure that the printer is on and click Send.  
Click OK when the confirmation message appears.  
The selected settings are enabled hereafter.



### Note

- Depending on print quality settings, effects of the quiet mode may be less.

## Advanced Guide

Advanced Guide > Changing the Printer Settings > Changing Printer Settings from Your Computer > Changing the Printer Operation Mode

# Changing the Printer Operation Mode

This function allows you to switch between various modes of printer operation.

The procedure for changing the printer settings is as follows:



### Custom Settings

1. Open the [printer driver setup window](#)
2. Make sure that the printer is on, and then click Custom Settings on the Maintenance tab

The Custom Settings dialog box opens.



#### Note

- If the printer is off or bi-directional communication is disabled, a message may appear because the computer cannot collect the printer status.  
If this happens, click OK to display the most recent settings specified on your computer.

3. If necessary, complete the following settings:

#### Ink Drying Wait Time

You can set the length of the printer rest time until printing of the next page begins. Moving the slider to the right increases the pause time and moving the slider to the left decreases the time.

If the paper gets stained because the next page is ejected before the ink on the printed page dries, increase the ink drying wait time.

Reducing the ink drying wait time speeds up printing.

4. Transmit the settings

Click Send. When the confirmation message appears, click OK.

The printer runs in the changed mode hereafter.

## Advanced Guide

Advanced Guide > Troubleshooting

---

### Troubleshooting

- ➔ [If an Error Occurs](#)
- ➔ [The Printer Can Not Be Powered On](#)
- ➔ [Alarm Lamp Flashes Orange](#)
- ➔ [Power Lamp Flashes Green and Alarm Lamp Flashes Orange Alternately](#)
- ➔ [Cannot Install the Printer Driver](#)
- ➔ [Cannot Connect to Computer Properly](#)
- ➔ [Print Results Not Satisfactory](#)
- ➔ [Printing Does Not Start](#)
- ➔ [Printing Stops Before It Is Completed](#)
- ➔ [Printer Moves But Ink Is Not Ejected](#)
- ➔ [Printing Speed Not as Fast as Expected](#)
- ➔ [FINE Cartridge Holder Does Not Move to the Position for Replacing](#)
- ➔ [Paper Does Not Feed Properly](#)
- ➔ [Paper Jams](#)
- ➔ [Message Appears on the Computer Screen](#)
- ➔ [For Windows Users](#)
- ➔ [FAQs](#)
- ➔ [If You Cannot Resolve the Problem](#)
- ➔ [Instructions for Use \(Printer Driver\)](#)

[Page top](#) ↕

## Advanced Guide

Advanced Guide > Troubleshooting > If an Error Occurs

### If an Error Occurs

When an error occurs in printing such as the printer is out of paper or paper is jammed, a troubleshooting message is displayed automatically. Take the appropriate action described in the message. The message may vary depending on the version of your operating system.

#### Windows

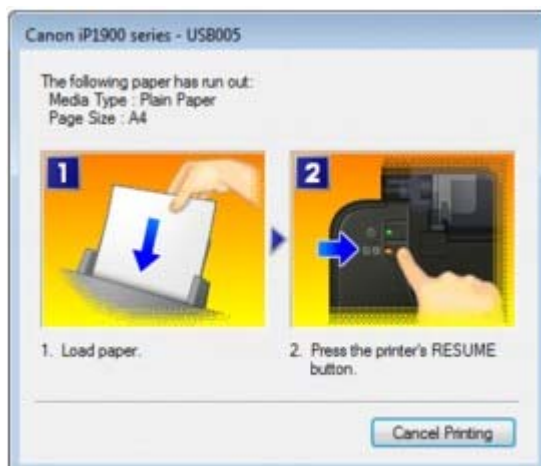

#### Macintosh

- In Mac OS X v.10.5.x:

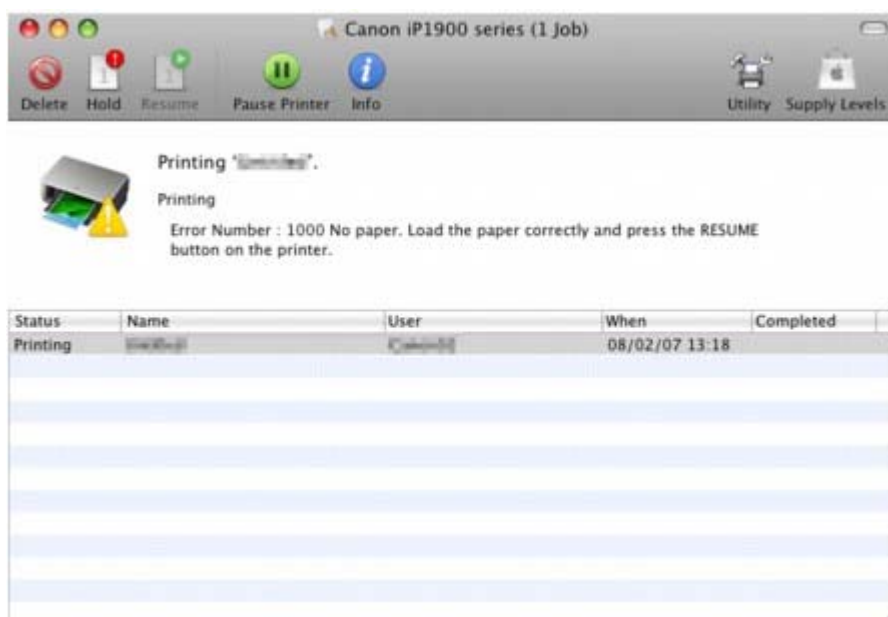

- In Mac OS X v.10.4.x or Mac OS X v.10.3.9:

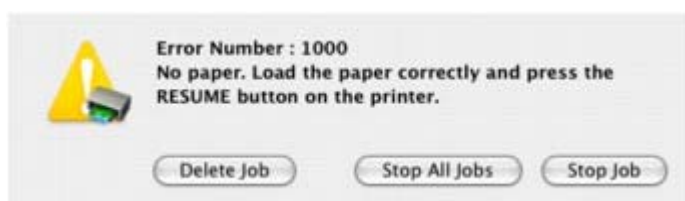

## Advanced Guide

[Advanced Guide](#) > [Troubleshooting](#) > [The Printer Cannot Be Powered On](#)

---

### The Printer Cannot Be Powered On

- **Check 1: Press the Power button.**
- **Check 2: Make sure that the power plug is securely plugged into the Power Cord Connector of the printer, then turn it back on.**
- **Check 3: Unplug the printer from the power supply, then plug the printer back in and turn the printer back on after leaving it for at least 5 minutes.**

If the problem is not resolved, contact your Canon service representative.

[Page top](#) ↕

## Advanced Guide

Advanced Guide > Troubleshooting > Alarm Lamp Flashes Orange

### Alarm Lamp Flashes Orange

When a printer error occurs, the **Alarm** lamp flashes orange as shown below. The number of flashes indicates the type of error that has occurred. Count the flashes and take the appropriate action to correct the error.



(A) Note the number of flashes

(B) Flashes repeatedly

Number of flashes/Cause	Action
Two flashes: Printer is out of paper. /Paper does not feed.	Reload paper on the Rear Tray and press the <b>RESUME/CANCEL</b> button.
Three flashes: Paper jam.	The paper may be jammed. Remove the jammed paper, reload paper properly in the printer, and then press the <b>RESUME/CANCEL</b> button. ➔ <a href="#">Paper Jams</a>
Four flashes: Ink has run out.	Ink has run out. Replace the ink cartridge and close the cover. If printing is in progress and you want to continue printing, press the <b>RESUME/CANCEL</b> button for at least 5 seconds with the ink cartridge installed. Then printing can continue under the ink out condition. The function for detecting the remaining ink level will be disabled. Replace the empty ink cartridge immediately after the printing. The resulting print quality is not satisfactory, if printing is continued under the ink out condition.
Five flashes: The FINE Cartridge cannot be recognized.	The FINE Cartridge may not be installed properly or it may not be compatible with this printer. Open the Front Cover and install the FINE Cartridge properly or install the one compatible with this printer. If the problem is not resolved, the FINE Cartridge may be faulty. In this case, contact your Canon service representative.
Seven Flashes: FINE Cartridge is not installed in the correct position.	Make sure that each FINE Cartridge is installed in the correct position. ➔ <a href="#">Routine Maintenance</a>
Eight flashes: Ink absorber is almost full.	The ink absorber is becoming full. The printer has a built-in ink absorber to hold the ink used during Print Head Cleaning. Press the <b>RESUME/CANCEL</b> button to cancel the error so you can continue printing. Before the ink absorber becomes completely full, contact a Canon service representative. (You will need to replace a particular part of the printer.)
Fourteen Flashes: The FINE Cartridge cannot be recognized.	The FINE Cartridge may not be compatible with this printer. Install the appropriate FINE Cartridge. ➔ <a href="#">Routine Maintenance</a>
Fifteen Flashes: The FINE Cartridge cannot be recognized.	The FINE Cartridge may not be installed properly or it may not be compatible with this printer. Install the appropriate FINE Cartridge. ➔ <a href="#">Routine Maintenance</a>
Sixteen Flashes: Ink level cannot be detected.	Ink may have run out. The function for detecting the remaining ink level will be

disabled since the ink level cannot be correctly detected.  
If you want to continue printing without this function, press the **RESUME/CANCEL** button for at least 5 seconds.  
Canon recommends to use new genuine Canon cartridges in order to obtain optimum qualities.  
Please be advised that Canon shall not be liable for any malfunction or trouble caused by continuation of printing under the ink out condition.

[Page top](#) ↕



## Advanced Guide

[Advanced Guide](#) > [Troubleshooting](#) > [Power Lamp Flashes Green and Alarm Lamp Flashes Orange Alternately](#)

# Power Lamp Flashes Green and Alarm Lamp Flashes Orange Alternately



A printer problem has occurred.

Disconnect the printer cable from the printer, turn the printer off, and then unplug the printer from the power supply.

Plug the printer back in and turn the printer back on.

If the problem is not resolved, contact your Canon service representative.

[Page top](#) ↕

## Advanced Guide

Advanced Guide > Troubleshooting > Cannot Install the Printer Driver

### Cannot Install the Printer Driver

- If the installation does not start even after the *Setup CD-ROM* is inserted into your computer's disc drive:

#### Windows

Start the installation following the procedure below.

1. Click Start then Computer.

In Windows XP, click Start then My Computer.

In Windows 2000, double-click the  My Computer icon on the desktop.

2. Double-click the  CD-ROM icon on the displayed window.

If the contents of the CD-ROM are displayed, double-click MSETUP4.EXE.

#### Macintosh

Double-click the  CD-ROM icon on your desktop to start installation.

#### note

- If the CD-ROM icon is not displayed, try the following:
  - Remove the CD-ROM from your computer, then insert it again.
  - Restart your computer.
- If the icon is still not displayed, try different discs and see if they are displayed. If other discs are displayed, there is a problem with the *Setup CD-ROM*. In this case, contact your Canon service representative.

- If you are unable to proceed beyond the Printer Connection screen:

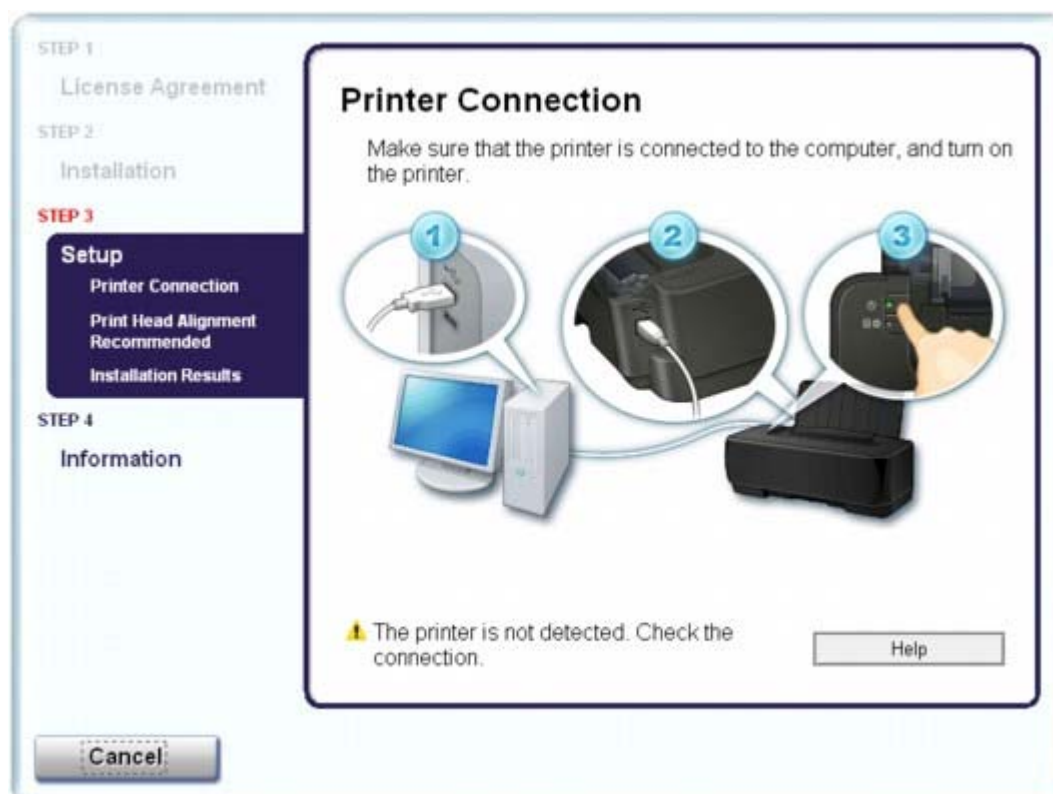

If you are unable to proceed beyond the Printer Connection screen, make sure that the USB cable is securely plugged into the USB port of the printer and is connected to the computer, and then follow

the procedure below to reinstall the printer driver.



- In Windows Vista, "The printer is not detected. Check the connection." may be displayed depending on the computer you use. In this case, wait for a while. If you still cannot proceed to the next step, follow the procedure below to reinstall the printer driver.
- 

1. Click Cancel on the Printer Connection screen.
2. Click Start Over on the Installation Failure screen.
3. Click Back on the screen that appears next.
4. Click Exit on the PIXMA XXX screen, then remove the CD-ROM.
5. Turn the printer off.
6. Restart the computer.
7. Make sure that you have no application software running.
8. Follow the procedure described in your setup manual to reinstall the printer driver.

- **In other cases:**

Follow the procedure described in your setup manual for proper installation.

If the driver was not installed correctly, uninstall the printer driver, restart your computer, then reinstall the driver.

➔ **Uninstalling the Printer Driver**

If you reinstall the printer driver, select Custom Install on the *Setup CD-ROM*.



- If the installer was forced to be terminated due to a Windows error, the system may be in an unstable condition and you may not be able to install the driver. Restart your computer before reinstalling.
-

## Advanced Guide

Advanced Guide > Troubleshooting > Cannot Connect to Computer Properly

---

# Cannot Connect to Computer Properly

## The Printer Is Not Recognized Properly

- **Check 1: Is a USB hub used?**

Connect the printer directly to the computer's USB port without using a hub.



- **Check 2: Is the latest USB driver installed correctly?**

Obtain the latest version of the USB driver and install it in your computer.

[Page top](#) ↑

## Advanced Guide

Advanced Guide > Troubleshooting > Print Results Not Satisfactory

### Print Results Not Satisfactory

If the print result is not satisfactory due to white streaks, misaligned lines, or uneven colors, confirm the paper and print quality settings first.

- **Check 1: Do the page size and media type settings match the size and type of the loaded paper?**

When these settings are incorrect, you cannot obtain a proper print result.

If you are printing a photograph or an illustration, incorrect paper type settings may reduce the quality of the printout color.

Also, if you print with an incorrect paper type setting, the printed surface may be scratched.

In borderless printing, uneven coloring may occur depending on the combination of the paper type setting and the loaded paper.

Confirm the page size and media type settings using the printer driver.

➔ [Printing with Easy Setup](#)

- **Check 2: Make sure that the appropriate print quality is selected according to the media type and printing data using the printer driver.**

Select a print quality option suitable for the paper and image for printing. If you notice blurs or uneven colors, increase the print quality setting and try printing again.

Confirm the print quality setting using the printer driver.

➔ [Changing the Print Quality and Correcting Image Data](#)

- **Check 3: If the problem is not resolved, there may be other causes.**

See also the sections below:

➔ [Cannot Print to End of Job](#)

➔ [No Printing Results/Printing Is Blurred/Colors Are Wrong/White Streaks](#)

➔ [Colors Are Unclear](#)

➔ [Lines Are Misaligned](#)

➔ [Printed Paper Curls or Has Ink Blots](#)

➔ [Paper Is Smudged/Printed Surface Is Scratched](#)

➔ [Back of the Paper Is Smudged](#)

➔ [Colors Are Uneven or Streaked](#)

## Advanced Guide

[Advanced Guide](#) > [Troubleshooting](#) > [Print Results Not Satisfactory](#) > [Cannot Print to End of Job](#)

---

### Cannot Print to End of Job

- **Check 1: Is the size of the print data extremely large?**



Click Print Options on the Page Setup sheet. Then, select the Prevent loss of print data check box in the displayed dialog.

- **Check 2: Is the space of your computer's hard disk sufficient?**

Delete unnecessary files to free disk space.

[Page top](#) ↕

## Advanced Guide

Advanced Guide > Troubleshooting > Print Results Not Satisfactory > No Printing Results/Printing Is Blurred/Colors Are Wrong/White Streaks

### No Printing Results/Printing Is Blurred/Colors Are Wrong/White Streaks

#### ❖ No Printing Results



#### ❖ Printing Is Blurred



#### ❖ Colors Are Wrong



#### ❖ White Streaks

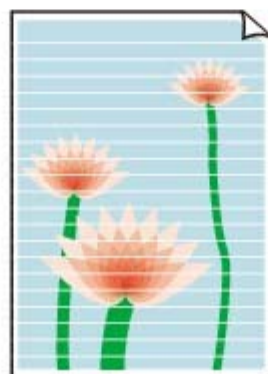

- **Check 1: Did you confirm the paper and print quality settings?**

➔ [Print Results Not Satisfactory](#)

- **Check 2: Is the FINE Cartridge installed properly?**

Remove the FINE Cartridge, then reinstall it. The print result may be improved by reinstalling the FINE Cartridge.



Also, check that the protective tape (A) is removed.

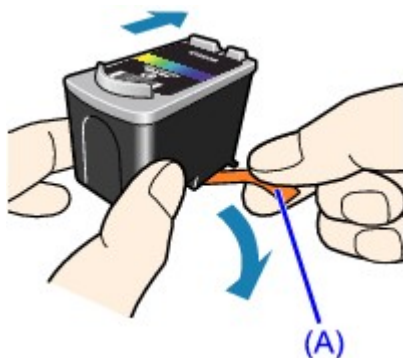

- **Check 3: Print the Nozzle Check Pattern and perform any necessary maintenance operations such as Print Head Cleaning.**

Print the Nozzle Check Pattern to determine whether the ink ejects properly from the print head nozzles.

Refer to [Routine Maintenance](#) for the Nozzle Check Pattern printing, Print Head Cleaning, and Print Head Deep Cleaning.

- If the Nozzle Check Pattern is not printed correctly:  
After performing the Print Head Cleaning, print the Nozzle Check Pattern and examine the pattern.
- If the problem is not resolved after performing the Print Head Cleaning twice:  
Perform the Print Head Deep Cleaning.  
If the problem is not resolved after performing the Print Head Deep Cleaning, try it again.
- If the problem is not resolved after performing the Print Head Deep Cleaning twice:  
Ink may have run out. Replace the FINE Cartridge.

- **Check 4: When a FINE Cartridge runs out of ink, replace it with a new one.**

- **Check 5: When using paper with one printable surface, make sure that the paper is loaded with the printable side facing up.**

Printing on the wrong side of such paper may cause unclear prints or prints with reduced quality.

Refer to the instruction manual supplied with the paper for detailed information on the printable side.

- **Check 6: Change the Paper Thickness Lever setting.**

Adjust the position of the Paper Thickness Lever according to the type of paper you are printing on.

Refer to [Loading Paper](#).

Depending on the printing content, the printing surface may become scratched or the corners or edges of the paper may become smudged even for the types of paper which require you to set the lever to the left. In this case, set the Paper Thickness Lever to the right.

\* Reset the Paper Thickness Lever to the left when you finish printing. If the lever is not set back to the left, the inside of the printer is more likely to get dirty due to the wider clearance between the print head and the loaded paper. It may also reduce print quality.



 **note**

---

- If the corners or edges of the paper are smudged, try to print with the Paper Thickness Lever set to the right.
- 

[Page top](#) ↕

## Advanced Guide

Advanced Guide > Troubleshooting > Print Results Not Satisfactory > Colors Are Unclear

### Colors Are Unclear

- **Check 1: Enable color correction.**

When printing photographs or other graphics, enabling color correction in the printer driver may improve color.



Select Vivid Photo in the Effects sheet in the printer properties dialog box.



Select Color Options in the pop-up menu in the Print dialog box, and then select Vivid Photo on the Color Mode.

In Mac OS X v 10.4.x or Mac OS X v 10.3.9, select Special Effects in the Print dialog box, and then select Vivid Photo.

- **Check 2: Is the FINE Cartridge installed properly?**

Remove the FINE Cartridge, then reinstall it. The print result may be improved by reinstalling the FINE Cartridge.



Also, check that the protective tape (A) is removed.

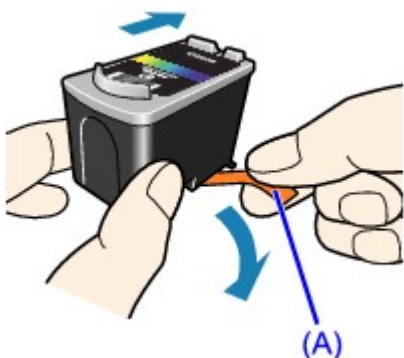

- **Check 3: When a FINE Cartridge runs out of ink, replace it with a new one.**

- **Check 4: Is the Nozzle Check Pattern printed properly?**

Print the Nozzle Check Pattern to determine whether the ink ejects properly from the print head nozzles.

Refer to [Routine Maintenance](#) for the Nozzle Check Pattern printing, Print Head Cleaning, and Print Head Deep Cleaning.

- If the Nozzle Check Pattern is not printed correctly:  
After performing the Print Head Cleaning, print the Nozzle Check Pattern and examine the pattern.
- If the problem is not resolved after performing the Print Head Cleaning twice:  
Perform the Print Head Deep Cleaning.

If the problem is not resolved after performing the Print Head Deep Cleaning, try it again.

- If the problem is not resolved after performing the Print Head Deep Cleaning twice:  
Ink may have run out. Replace the FINE Cartridge.

---

 **note**

- Printed colors may not match screen colors due to basic differences in the methods used to produce colors. Color control settings and environmental differences can also affect how colors appear on the screen.
- 

[Page top](#) ↑

## Advanced Guide

Advanced Guide > Troubleshooting > Print Results Not Satisfactory > Lines Are Misaligned

### Lines Are Misaligned



- **Check 1: Did you confirm the paper and print quality settings?**

➔ [Print Results Not Satisfactory](#)

- **Check 2: Perform Print Head Alignment**

If you did not align the Print Head after installation, straight lines may be printed misaligned.

➔ [Routine Maintenance](#)



- **Check 3: Is the size of the print data extremely large?**

Click Print Options on the Page Setup sheet. Then, select the Prevent loss of print data check box in the displayed dialog.

- **Check 4: Is the Printing layout printing or Binding margin function being used?**

When the Printing layout printing or Binding margin function is being used, thin lines may not be printed. Try thickening the lines in the document.

[Page top](#) ↕

## Advanced Guide

[Advanced Guide](#) > [Troubleshooting](#) > [Print Results Not Satisfactory](#) > [Printed Paper Curls or Has Ink Blots](#)

# Printed Paper Curls or Has Ink Blots

## Printed Paper Curls



## Printed Paper Has Ink Blots



- **Check 1: Did you confirm the paper and print quality settings?**

➔ [Print Results Not Satisfactory](#)

- **Check 2: If the intensity is set high, reduce the Intensity setting in the printer driver and try printing again.**

If you are using plain paper to print images with high intensity, the paper may absorb too much ink and become wavy, causing paper abrasion.

Confirm the intensity using the printer driver.

➔ [Adjusting Intensity](#)

- **Check 3: Is Photo Paper being used for printing photographs?**

When printing data with high color saturation such as photographs or images in deep color, we recommend using Photo Paper Plus Glossy II or other Canon speciality paper.

➔ [Loading Paper](#)

[Page top](#) ↕

## Advanced Guide

Advanced Guide > Troubleshooting > Print Results Not Satisfactory > Paper Is Smudged/Printed Surface Is Scratched

# Paper Is Smudged/Printed Surface Is Scratched

## ▶ Paper Is Smudged

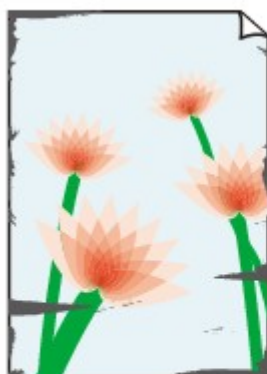

**The Edges of Paper Are Smudged**



**Printed Surface Is Smudged**



## ▶ Printed Surface Is Scratched

- **Check 1: Did you confirm the paper and print quality settings?**

➔ [Print Results Not Satisfactory](#)

- **Check 2: Is the appropriate type of paper being used? Check the**

**following:**

- Check to see if the paper you are printing on is suitable for your printing purpose.
  - ➔ [Loading Paper](#)
- When performing Borderless Printing, make sure that the paper you are using is suitable for Borderless Printing. If the paper you are using is not suitable for Borderless Printing, the print quality may be reduced at the top and bottom edges of the paper.
  - ➔ [Printing Area](#)

- **Check 3: Load the paper after correcting its curl.**

- **For Plain Paper**

Turn the paper over and reload it to print on the other side.

Leaving the paper loaded on the Rear Tray for a long time may cause the paper to curl. In this case, load the paper with the other side facing up. It may resolve the problem.

We recommend putting unused paper back into the package and keep it on a level surface.

- **For Other Paper**

1. With the printing side (A) facing up, cover the paper with a fresh sheet of plain paper to avoid staining or scratching the surface.
2. Roll up the paper in the opposite direction to the paper curl as seen below.

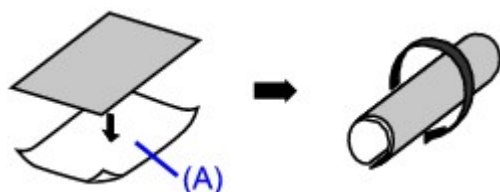

3. Check to see that the paper curl is within approximately 0.08 to 0.2 inches / 2 to 5 mm (B) in height.

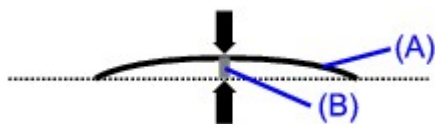

We recommend printing curl-corrected paper one sheet at a time.



#### note

- Depending on the media type, the paper may be smudged or may not be fed properly even if it is not curled. In such cases, follow the procedure described above to curl the paper before printing. This may improve the print result.

### • Check 4: If intensity is set high, reduce the Intensity setting in the printer driver and try printing again.

If you are using plain paper to print images with high intensity, the paper may absorb too much ink and become wavy, causing paper abrasion.

Reduce the Intensity setting in the printer driver and try printing again.



- Open the printer properties dialog box.  
→ [Opening the Printer Properties Dialog Box \(Windows\)](#)
- On the Main sheet, select Manual for Color/Intensity, and then click Set.
- Drag the Intensity slide bar on the Color Adjustment sheet to adjust the intensity.



- Open the Print dialog box.  
→ [Opening the Page Setup and Print Dialog Box \(Macintosh\)](#)
- Select Color Options in the pop-up menu.
- Drag the Intensity slide bar to set the intensity.

### • Check 5: Is printing performed beyond the recommended printing area?

If you are printing beyond the recommended printing area of your printing paper, the lower edge of the paper may become stained with ink.

Resize your original document in your application software.

→ [Printing Area](#)

### • Check 6: Is the Paper Feed Roller dirty?

Clean the Paper Feed Roller.

→ [Routine Maintenance](#)



#### note

- Cleaning the Paper Feed Roller will wear the roller, so perform this procedure only when necessary.

### • Check 7: Is the inside of the printer dirty?

When performing duplex printing, the inside of the printer may become stained with ink, causing the printout to become smudged.

Perform the Bottom Plate Cleaning to clean the inside of the printer.

→ [Cleaning Inside the Printer](#)



#### note

- To prevent the inside of the printer from stains, set the paper size correctly.

- **Check 8: Set Ink Drying Wait Time longer.**

Doing so gives the printed surface enough time to dry so that paper smudged and scratched are prevented.



1. Make sure that the printer is turned on.
2. Open the printer properties dialog box.  
→ [Opening the Printer Properties Dialog Box \(Windows\)](#)
3. Click the Maintenance tab and then Custom Settings.
4. Drag the Ink Drying Wait Time slide bar to set the wait time, and then click Send.
5. Confirm the message and click OK.



1. Make sure that the printer is turned on.
2. Open the Canon IJ Printer Utility.  
→ [Opening the Canon IJ Printer Utility \(Macintosh\)](#)
3. Select Custom Settings in the pop-up menu.
4. Drag the Ink Drying Wait Time slide bar to set the wait time, and then click Send.
5. Confirm the message and click OK.

- **Check 9: Change the Paper Thickness Lever setting.**

Adjust the position of the Paper Thickness Lever according to the type of paper you are printing on. Refer to [Loading Paper](#).

Depending on the printing content, the printing surface may become scratched or the corners or edges of the paper may become smudged even for the types of paper which require you to set the lever to the left. In this case, set the Paper Thickness Lever to the right.

\* Reset the Paper Thickness Lever to the left when you finish printing. If the lever is not set back to the left, the inside of the printer is more likely to get dirty due to the wider clearance between the print head and the loaded paper. It may also reduce print quality.

**note**

- If the corners or edges of the paper are smudged, try to print with the Paper Thickness Lever set to the right.

- **Check 10: Is the paper scratched by other loaded paper?**

Depending on the media type, the paper may be scratched by other loaded paper when feeding from the Rear Tray. In this case, load one sheet at a time.



## Advanced Guide

Advanced Guide > Troubleshooting > Print Results Not Satisfactory > Back of the Paper Is Smudged

### Back of the Paper Is Smudged

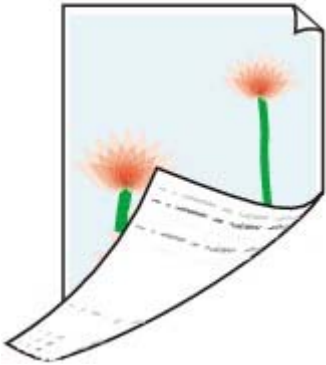

- **Check 1: Did you confirm the paper and print quality settings?**
  - ➔ [Print Results Not Satisfactory](#)
- **Check 2: Perform the Bottom Plate Cleaning to clean the inside of the printer.**
  - ➔ [Cleaning Inside the Printer](#)



**note**

- When performing duplex printing or too much printing, the inside may become stained with ink.

[Page top](#) ↕

## Advanced Guide

Advanced Guide > Troubleshooting > Print Results Not Satisfactory > Colors Are Uneven or Streaked

# Colors Are Uneven or Streaked

## ▣ Colors Are Uneven



## ▣ Colors Are Streaked



- **Check 1: Did you confirm the paper and print quality settings?**

➔ [Print Results Not Satisfactory](#)

- **Check 2: Print the Nozzle Check Pattern and perform any necessary maintenance operations such as Print Head Cleaning.**

Print the Nozzle Check Pattern to determine whether the ink ejects properly from the print head nozzles.

Refer to [Routine Maintenance](#) for the Nozzle Check Pattern printing, Print Head Cleaning, and Print Head Deep Cleaning.

- If the Nozzle Check Pattern is not printed correctly:  
After performing the Print Head Cleaning, print the Nozzle Check Pattern and examine the pattern.
- If the problem is not resolved after performing the Print Head Cleaning twice:  
Perform the Print Head Deep Cleaning.  
If the problem is not resolved after performing the Print Head Deep Cleaning, try it again.
- If the problem is not resolved after performing the Print Head Deep Cleaning twice:  
Ink may have run out. Replace the FINE Cartridge.

- **Check 3: Perform Print Head Alignment.**

➔ [Routine Maintenance](#)

## Advanced Guide

Advanced Guide > Troubleshooting > Printing Does Not Start

### Printing Does Not Start

- **Check 1: Make sure that the power plug is securely plugged in, then turn the printer on.**

While the **Power** lamp is flashing green, the printer is initializing. Wait until the **Power** lamp stops flashing and remains lit green.



- When printing large data such as a photo or graphics, it may take longer to start printing. While the **Power** lamp is flashing green, the computer is processing data and sending it to the printer. Wait until printing starts.

- **Check 2: Make sure that the USB cable is securely plugged in to the printer and the computer, then check the following:**

- If you are using a relay device such as a USB hub, disconnect it, connect the printer directly to the computer, and try printing again. If printing starts normally, there is a problem with the relay device. Consult the reseller of the relay device for details.
- There could also be a problem with the USB cable. Replace the USB cable and try printing again.

- **Check 3: Restart your computer.**

If there are any unnecessary print jobs, delete them.

➔ [Deleting the Undesired Print Jobs](#)

- **Check 4: Make sure that your printer's name is selected in the Print dialog box.**

The printer will not print properly if you are using a driver for a different printer.

In Windows, make sure that your printer's name is selected in the Print dialog box.

On a Macintosh, make sure that your printer's name is selected in Printer in the Print dialog box.



- To make the printer the one selected by default, select Set as Default Printer (Windows), Default Printer or Make Default (Macintosh).



- **Check 5: Configure the printer port appropriately.**

Configure "USBnnn" (where "n" is a number) as the printer port.

1. Log on as a user account with administrator privilege.
2. Click Control Panel, then Printer under Hardware and Sound.  
In Windows XP, click Control Panel, Printers and Other Hardware, then Printers and Faxes.  
In Windows 2000, click Control Panel then Printers.
3. Right-click the Canon XXX icon, then select Properties.
4. Click the Ports tab to confirm the port settings.

Make sure that a port named USBnnn (where "n" is a number) with Canon XXX appearing in the Printer column is selected for Print to the following port(s).

If the setting is incorrect, reinstall the printer driver or change the printer port to the correct one.

## Advanced Guide

Advanced Guide > Troubleshooting > Printing Stops Before It Is Completed

# Printing Stops Before It Is Completed

- **Check 1: Has the printer been printing continuously for a long period?**

If the printer has been printing continuously for a long time, the Print Head may overheat. To protect the Print Head, the printer may stop printing at a line break for a period of time and then resume printing.

In this case, interrupt your print session at a convenient time and turn the printer off for at least 15 minutes.

Additionally, if the printer has been printing graphics or photos with intense colors continuously over a period of time, the printer may stop printing to protect the Print Head. In this case, printing will not resume automatically. Turn the printer off for at least 15 minutes.

### **caution**

- The Print Head and the surrounding area can become extremely hot inside the printer. Never touch the Print Head or nearby components.

- **Check 2: Is the paper loaded?**

Make sure that paper is loaded in the Rear Tray.

If the printer has run out of paper, load paper.

- **Check 3: Do the printing documents have lots of photographs or illustrations?**

Printing large data such as photos or graphics takes time for the printer and the computer to process, during which the printer may appear to have stopped operating.

In addition, when printing data that uses a large amount of ink continuously on plain paper, the printer may pause temporarily. In either case, wait until the process is complete.

### **note**

- If you are printing a document with a large printing area or printing multiple copies of a document, printing may pause to allow the ink to dry.

## Advanced Guide

Advanced Guide > Troubleshooting > Printer Moves But Ink Is Not Ejected

### Printer Moves But Ink Is Not Ejected

#### • Check 1: Are the Print Head nozzles clogged?

Print the Nozzle Check Pattern to determine whether the ink ejects properly from the print head nozzles.

Refer to [Routine Maintenance](#) for the Nozzle Check Pattern printing, Print Head Cleaning, and Print Head Deep Cleaning.

- If the Nozzle Check Pattern is not printed correctly:  
After performing the Print Head Cleaning, print the Nozzle Check Pattern and examine the pattern.
- If the problem is not resolved after performing the Print Head Cleaning twice:  
Perform the Print Head Deep Cleaning  
If the problem is not resolved after performing the Print Head Deep Cleaning, try it again.
- If the problem is not resolved after performing the Print Head Deep Cleaning twice:  
Ink may have run out. Replace the FINE Cartridge.

#### • Check 2: Is the FINE Cartridge installed properly?

Remove the FINE Cartridge, then reinstall it. The print result may be improved by reinstalling the FINE Cartridge.



Also, check that the protective tape (A) is removed.

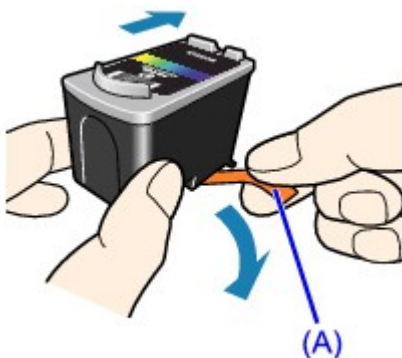

- **Check 3: When a FINE Cartridge runs out of ink, replace it with a new one.**

## Advanced Guide

Advanced Guide > Troubleshooting > Printing Speed Not as Fast as Expected

# Printing Speed Not as Fast as Expected

## • Check 1: Is printing performed in Quiet Mode?

Print speed is reduced if you specified to print in Quiet Mode in the printer driver. For faster printing, do not print in Quiet Mode.

➔ [Reducing the Printer Noise](#)

## • Check 2: Is the print quality set too high?

Increase the printing speed setting in the printer driver. Setting to prioritize speed makes printing faster.



### 1. Open the printer properties dialog box.

➔ [Opening the Printer Properties Dialog Box \(Windows\)](#)

### 2. On the Main sheet, select Fast for the Print Quality setting.

Depending on the media type, the Fast option may not be available.



### 1. Open the Print dialog box.

➔ [Opening the Page Setup and Print Dialog Box \(Macintosh\)](#)

### 2. Select Quality & Media in the pop-up menu and then select Fast for the Print Quality setting.

Depending on the media type, the Fast option may not be available.



#### note

- Printing speed may not improve noticeably by following the instructions above, depending on your system environment.

## Advanced Guide

Advanced Guide > Troubleshooting > FINE Cartridge Holder Does Not Move to the Position for Replacing

# FINE Cartridge Holder Does Not Move to the Position for Replacing

- **Check 1: Is the Power lamp off?**

Check if the **Power** lamp is lit green.

The FINE Cartridge Holder will not move unless the power is on. If the **Power** lamp is off, close the Front Cover and turn the printer on.

While the **Power** lamp is flashing green, the printer is initializing. Wait until the **Power** lamp stops flashing and remains lit green, and then open the Front Cover again.

- **Check 2: Is the Alarm lamp flashing?**

Close the Front Cover, confirm the number of times the Alarm lamp is flashing, take the appropriate action to resolve the error, and then reopen it. For details on how to resolve the error, see [Alarm Lamp Flashes Orange](#).

- **Check 3: Has the Front Cover been left open for 10 minutes or longer?**

If the Front Cover is left open for more than 10 minutes, the FINE Cartridge Holder moves to the right to prevent the Print Head from drying out. Close and reopen the Front Cover to return the FINE Cartridge Holder to the left.

- **Check 4: Has the printer been printing continuously for a long period?**

Close the Front Cover, wait a while, then reopen it.

If the printer has been printing continuously for a long time, the Print Head will overheat, and the printer stops printing temporarily to protect the Print Head.



### note

- Opening the Front Cover while printing moves the FINE Cartridge Holder to the right. Close the Front Cover, and reopen it after printing is complete.

## Advanced Guide

Advanced Guide > Troubleshooting > Paper Does Not Feed Properly

### Paper Does Not Feed Properly

- **Check 1: Make sure of the following when you load paper.**

- When loading two or more sheets of paper, align the edges of the sheets before loading.
- When loading two or more sheets of paper, make sure that the paper stack does not exceed the paper support load limit.  
However, proper feeding of paper may not be possible at this maximum capacity depending on the type of paper or environmental conditions (either very high or low temperature and humidity). In such cases, reduce the sheets of paper you load at a time to less than half of the paper support load limit.
- Always load the paper in portrait orientation, regardless of the printing orientation.
- When you load the paper, load the paper with the print side facing UP. Align the paper stack against the right side of the Rear Tray and slide the Paper Guide so that it just touches the left edge of the stack.

➔ [Loading Paper](#)

- **Check 2: Check to see if the paper you are printing on is too thick or curled.**

➔ [Loading Paper](#)

- **Check 3: Make sure of the following when you load envelopes.**

- When printing on envelopes, refer to [Loading Paper](#), and prepare the envelopes before printing. Once you have prepared the envelopes, load them in portrait orientation. If the envelopes are placed in landscape orientation, they will not feed properly.
- Set the Paper Thickness Lever to the right.

➔ [Loading Paper](#)

- **Check 4: Remove any foreign objects from the Rear Tray.**

- **Check 5: Turn off the printer, open the Front Cover, and remove the foreign object.**

Be careful not to touch the components inside the printer.

- **Check 6: Clean the Paper Feed Roller.**

➔ [Routine Maintenance](#)



#### note

- Cleaning the Paper Feed Roller will wear the roller, so perform this procedure only when necessary.



## Advanced Guide

Advanced Guide > Troubleshooting > Paper Jams

# Paper Jams

### note

- If you need to turn off the printer to remove jammed paper during printing, press the **RESUME/CANCEL** button to cancel print jobs before turning off the printer.

## If the paper is jammed in the Paper Output Slot or the Rear Tray:

Remove the paper following the procedure below.

1. Slowly pull the paper out, either from the Rear Tray or from the Paper Output Slot, whichever is easier.



### note

- If the paper tears and a piece remains inside the printer, turn the printer off, open the Front Cover, and remove the paper. Be careful not to touch the components inside the printer. After removing all paper, close the Front Cover, and turn the printer back on.
- If you cannot pull the paper out, turn the printer off and turn it back on. The paper may be ejected automatically.

2. Reload the paper, and press the **RESUME/CANCEL** button on the printer.

If you turned off the printer in step (1), all print jobs in the queue are canceled. Reprint if necessary.

### note

- When reloading the paper, confirm that you are using the correct paper and are loading it correctly.  
➔ [Loading Paper](#)
- A5-sized paper is suited to printing documents consisting mainly of text. We do not recommend using such paper to print documents with photos or graphics, since the printout may curl and cause paper exit jams.

If you cannot remove the paper or the paper tears inside the printer, or if the paper jam error continues after removing the paper, contact your Canon service representative.

## In other cases:

Make sure of the following:







- **Check 1: Are there any foreign objects in the Rear Tray or around the Paper Output Slot?**
- **Check 2: Is the paper curled?**  
➔ [Check 3: Load the paper after correcting its curl.](#)



## Advanced Guide

Advanced Guide > Troubleshooting > Message Appears on the Computer Screen

# Message Appears on the Computer Screen

- ➔ Service Error 5100 Is Displayed
- ➔  Writing Error/Output Error/Communication Error
- ➔  Error Number: 300 Is Displayed
- ➔  Error Number: 1700 Is Displayed
- ➔  Ink Info Number: 1688 Is Displayed
- ➔  Ink Info Number: 1686 Is Displayed
- ➔  Other Error Messages

## Service Error 5100 Is Displayed

- **Check: Is the movement of the FINE Cartridge Holder blocked?**

Cancel printing from your computer, turn off the printer. Then clear the jammed paper or protective material that is preventing the FINE Cartridge Holder from moving.

### important

- Be careful not to touch the components inside the printer. The printer may not print out properly if you touch it.

Turn the printer back on.

If the problem is not resolved, contact your Canon service representative.

## Writing Error/Output Error/Communication Error

- **Check 1: If the Power lamp is off, make sure that the power plug is plugged in, then turn the printer on.**

While the **Power** lamp is flashing green, the printer is initializing. Wait until the **Power** lamp stops flashing and remains lit green.
- **Check 2: Make sure that the printer port is configured appropriately in the printer driver.**

\* In the following instructions, "XXX" signifies your printer's name.

### 1. Log on as a user account with administrator privilege.

### 2. Click Control Panel, then Printer under Hardware and Sound.

In Windows XP, click Control Panel, Printers and Other Hardware, then Printers and Faxes.

In Windows 2000, click Control Panel then Printers.

### 3. Right-click the Canon XXX icon, then select Properties.

### 4. Click the Ports tab to confirm the port settings.

Make sure that a port named USBnxx (where "n" is a number) with Canon XXX appearing in the Printer column is selected for Print to the following port(s).

If the port setting is not correct, reinstall the printer driver or change the port setting according to the interface you are using.

- **Check 3: Make sure that the USB cable is securely plugged in to the printer and the computer.**
  - If you are using a relay device such as a USB hub, disconnect it, connect the printer

directly to the computer, and try printing again. If printing starts normally, there is a problem with the relay device. Consult the reseller of the relay device for details.

- There could also be a problem with the USB cable. Replace the USB cable and try printing again.

- **Check 4: Make sure that the printer driver is installed correctly.**

Uninstall the printer driver following the procedure described in [Uninstalling the Printer Driver](#) and reinstall it following the procedure described in your setup manual.

- **Check 5: Check the status of the device on your computer.**

Follow the procedure below to check the status of the device.

- 1. Click Control Panel, Hardware and Sound, then Device Manager.**

If the User Account Control screen is displayed, follow the on-screen instructions.

In Windows XP, click Control Panel, Performance and Maintenance, System, then click Device Manager on the Hardware sheet.

In Windows 2000, click Control Panel, System, then Device Manager on the Hardware sheet.

- 2. Double-click Universal Serial Bus controllers then USB Printing Support.**

If USB Printing Support is not displayed, make sure that the printer is correctly connected to the computer.

➔ [Check 3: Make sure that the USB cable is securely plugged in to the printer and the computer.](#)

- 3. Click the General tab and make sure that there is no indication of a problem with the device.**

If a device error is displayed, refer to Windows help to resolve the error.

## **Macintosh** Error Number: 300 Is Displayed

- **Check 1: If the Power lamp is off, make sure that the power plug is plugged in, then turn the printer on.**

While the **Power** lamp is flashing green, the printer is initializing. Wait until the **Power** lamp stops flashing and remains lit green.

- **Check 2: Make sure that the USB cable is securely plugged in to the printer and the computer.**

- If you are using a relay device such as a USB hub, disconnect it, connect the printer directly to the computer, and try printing again. If printing starts normally, there is a problem with the relay device. Consult the reseller of the relay device for details.
- There could also be a problem with the USB cable. Replace the USB cable and try printing again.

- **Check 3: Make sure that your printer's name is selected in the Print dialog box.**

➔ [Opening the Page Setup and Print Dialog Box \(Macintosh\)](#)

## **Macintosh** Error Number: 1700 Is Displayed

- **See [Eight flashes: in Alarm Lamp Flashes Orange](#) and take the appropriate action.**

## **Macintosh** Ink Info Number: 1688 Is Displayed

- **See [Four flashes: in Alarm Lamp Flashes Orange](#) and take the appropriate action.**

### **Macintosh** Ink Info Number: 1686 Is Displayed

- See **Sixteen Flashes: in Alarm Lamp Flashes Orange** and take the appropriate action.

### **Windows** Other Error Messages

- **Check: If an error message is displayed outside the printer status monitor, check the following:**
  - "Could not spool successfully due to insufficient disk space"  
Delete any unnecessary files to increase the amount of free space on the disk.
  - "Could not spool successfully due to insufficient memory"  
Quit other running applications to increase available memory.  
If you still cannot print, restart your computer and retry printing.
  - "Printer driver could not be found"  
Uninstall the printer driver according to the procedure described in [Uninstalling the Printer Driver](#), and then reinstall it.
  - "Could not print Application name - File name"  
Try printing again once the current job is complete.

## Advanced Guide

Advanced Guide > Troubleshooting > For Windows Users

# For Windows Users

## Printer Status Monitor Is Not Displayed

- **Check: Is the printer status monitor enabled?**

Make sure that Enable Status Monitor is selected on the Option menu of the printer status monitor.

1. **Open the printer properties dialog box.**

➔ [Opening the Printer Properties Dialog Box \(Windows\)](#)

2. **On the Maintenance sheet, click View Printer Status.**

3. **Select Enable Status Monitor on the Option menu if it is not selected.**

## The Inkjet Printer/Scanner Extended Survey Program Screen Is Displayed

If the Inkjet Printer/Scanner Extended Survey Program is installed, the confirmation screen asking to send the printer usage information will be displayed three months and then six months after the installation. After that, it will be displayed every half a year for about four years.

Read the instructions on the screen and follow the procedure below.

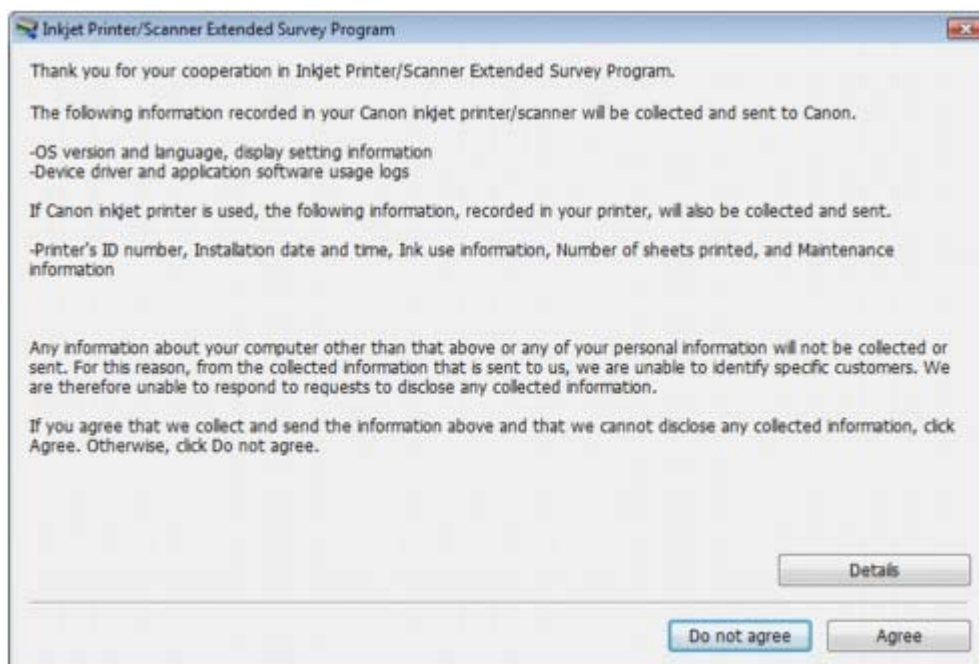

- **If you agree to participate in the survey program:**

Click Agree, then follow the on-screen instructions. The printer usage information will be sent to Canon via the Internet.

 **note**

- When sending the information, the caution screen such as an Internet security screen may be displayed. In this case, confirm the program name is "IJPLMUI.exe", then allow it.

- **If you do not agree to participate in the survey program:**

Click Do not agree. The confirmation screen will be closed, and the survey at that time is skipped. The confirmation screen will be displayed again three months later.

- **To uninstall the Inkjet Printer/Scanner Extended Survey Program:**

To uninstall the Inkjet Printer/Scanner Extended Survey Program, click Details, then click Uninstall on the detail description screen. Once the program has been uninstalled, neither the survey nor the transmission of the printer usage information will be performed.

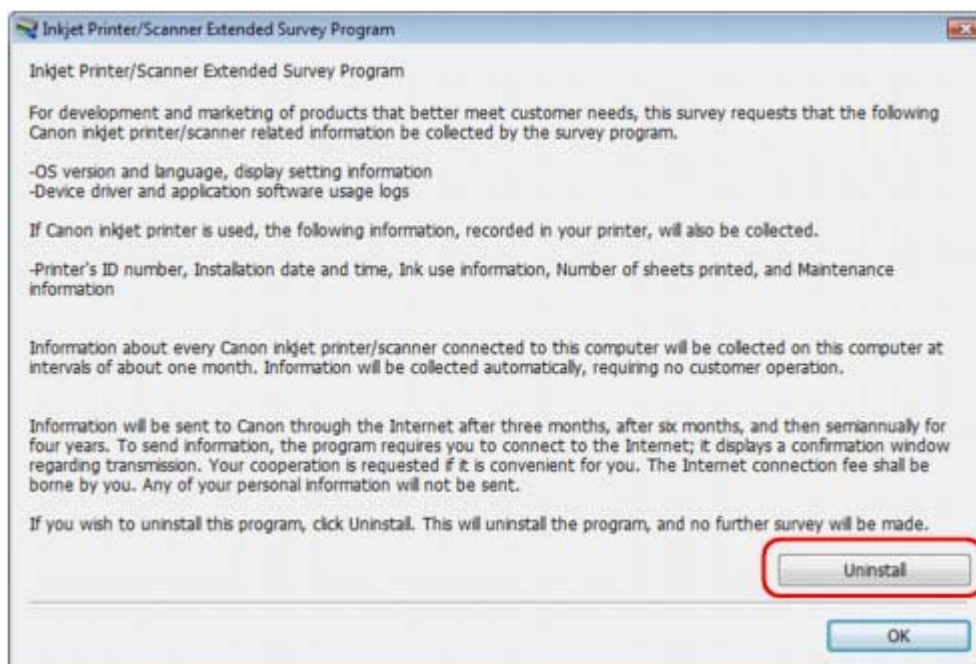

## Advanced Guide

Advanced Guide > Troubleshooting > FAQs

---

### FAQs

- ➔ No Printing Results/Printing Is Blurred/Colors Are Wrong/White Streaks
- ➔ Printer Moves But Ink Is Not Ejected
- ➔ Cannot Install the Printer Driver
- ➔ Printing Does Not Start
- ➔ Printing Stops Before It Is Completed
- ➔  Writing Error/Output Error/Communication Error
- ➔ Print Results Not Satisfactory
- ➔ Paper Jams
- ➔ Paper Does Not Feed Properly

[Page top](#) ↑



## Advanced Guide

[Advanced Guide](#) > [Troubleshooting](#) > [If You Cannot Resolve the Problem](#)

---

### If You Cannot Resolve the Problem

If you cannot resolve the problem with any of the workarounds in this chapter, please contact the seller of the printer or a Canon service representative.

Canon support staff are trained to be able to provide technical support to satisfy customers.

#### **caution**

- If the printer emits any unusual sound, smoke, or odor, turn it off immediately. Unplug the power cord from the outlet and contact the seller or your Canon service representative. Never attempt to repair or disassemble the printer yourself.
  - Attempts by customers to repair or take apart the printer will invalidate any warranty regardless of whether the warranty has expired.
- 

Before contacting your Canon service representative, confirm the following:

- Product name:
  - \* Your printer's name is located on the front cover of the setup manual.
- Serial number: please refer to the setup manual
- Details of the problem
- What you tried to solve the problem, and what happened

[Page top](#) ↕

## Advanced Guide

Advanced Guide > Troubleshooting > Instructions for Use (Printer Driver)

# Instructions for Use (Printer Driver)

This printer driver is subject to the following restrictions. Keep the following points in mind when using the printer driver.

## Restrictions on the Printer Driver

- With some applications, the Copies setting in the Page Setup tab of the printer driver may not be enabled.  
In this case, use the copies setting in the Print dialog box of the application software.
- If the selected Language in the About dialog box does not match the operating system interface language, the driver screen may not be displayed properly.
- Do not change the Advanced tab items of the printer properties. If you change any of the items, you will not be able to use the following functions correctly.  
Also, if Print to file is selected in the Print dialog box of the application software and with applications that prohibit EMF spooling, such as Adobe Photoshop LE and MS Photo Editor, the following functions will not operate.
  - Preview before printing on the Main tab
  - Prevent loss of print data in the Print Options dialog box
  - Page Layout Printing, Poster Printing, Booklet Printing, Duplex Printing, Specify Margin..., Print from Last Page, Collate, and Stamp/Background... on the Page Setup tab
- Since the resolution in the preview display differs from the printing resolution, text and lines in the preview display may appear different from the actual print result.
- With some applications, the printing is divided into multiple print jobs.  
To cancel printing, delete all divided print jobs.
- If image data is not printed correctly, display the Print Options dialog box from the Page Setup tab and change the setting of Disable ICM required from the application software. This may solve the problem.
- Software windows may not appear correctly on Windows Vista when fonts are set to Larger scale. If you want to display the windows with Larger scale fonts, set the desktop theme to Windows Classic as follows:
  1. Select Control Panel from the Start menu.
  2. Select Appearance and Personalization -> Personalization -> Theme.  
The Theme Settings dialog box opens.
  3. At the Theme Settings dialog box, click the Themes tab, and select Windows Classic from Theme.
  4. Click OK.  
Desktop changes to Windows Classic display.

## Points to Note with Applications

- There are following restrictions in Microsoft Word (Microsoft Corporation).
  - If Microsoft Word has the same printing functions as the printer driver, use Word to specify them.
  - When selecting Scaled Printing, Fit-to-Page Printing, or Page Layout Printing from the Page Layout list on the Page Setup tab, the selected printing function may not be effective, depending on the version of Word.  
If this happens, follow the procedure below.
    1. Open Word's Print dialog box.
    2. Open the printer driver setup window, specify Page Layout on the Page Setup tab, and click OK.
    3. Without starting printing, close the Print dialog box.
    4. Open Word's Print dialog box again.
    5. Open the printer driver setup window again and click OK.
    6. Start printing.
- Illustrator/Adobe Systems Inc.  
If Bitmap Printing takes effect, printing may take time or some data may not be printed. Print after clearing the Bitmap Printing check box in the Print dialog box.



## Advanced Guide

Advanced Guide > Appendix

---

### Appendix

- ➔ [Printing Area](#)
- ➔ [Deleting the Undesired Print Jobs](#)
- ➔ [Updating the Printer Driver](#)
- ➔ [Uninstalling the On-Screen Manuals](#)
- ➔ [Transporting and Storing the Printer](#)
- ➔ [Opening the Printer Properties Dialog Box \(Windows\)](#)
- ➔ [Opening the Page Setup and Print Dialog Box \(Macintosh\)](#)
- ➔ [Opening the Canon IJ Printer Utility \(Macintosh\)](#)
- ➔ [Connecting the Printer to the Network](#)

[Page top](#) ↕

## Advanced Guide

Advanced Guide > Appendix > Printing Area

### Printing Area

To ensure the best print quality, the printer allows a margin along each edge of media. The actual printable area will be the area inside these margins.

Recommended printing area : Canon recommends that you print within this area.

Printable area : The area where it is possible to print.

However, printing in this area can affect the print quality or the paper feed precision.

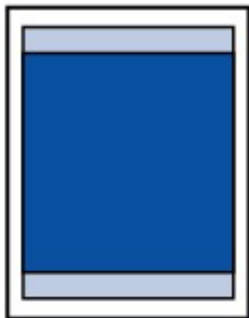

#### note

##### ■ Borderless Printing

- By selecting Borderless Printing option, you can make prints with no margins.
- When performing Borderless Printing, slight cropping may occur at the edges since the printed image is enlarged to fill the whole page.

For Borderless Printing, use the following paper.

- Glossy Photo Paper "Everyday Use" GP-501
- Photo Paper Glossy GP-502
- Photo Paper Plus Semi-Gloss SG-201
- Photo Paper Plus Glossy II PP-201
- Photo Paper Pro II PR-201
- Matte Photo Paper MP-101

Performing Borderless Printing on any other type of paper may substantially reduce printing quality and/or result in printouts with altered color hues.

Borderless Printing on plain paper may result in printouts with reduced quality. Use them only for test printing.

- Depending on the type of paper, Borderless Printing may reduce the print quality at the top and bottom edges of the paper or cause these parts to become smudged.

➔ Letter, Legal

➔ Envelopes

➔ Other Sizes than Letter, Legal, Envelops

## Advanced Guide

Advanced Guide > Appendix > Printing Area > Other Sizes than Letter, Legal, Envelops

### Other Sizes than Letter, Legal, Envelops

Size	Printable Area (width x height)
A5	5.56 x 7.95 inches / 141.2 x 202.0 mm
A4	8.00 x 11.38 inches / 203.2 x 289.0 mm
B5	6.90 x 9.80 inches / 175.2 x 249.0 mm
4" x 6" / 10 x 15 cm	3.73 x 5.69 inches / 94.8 x 144.4 mm
4" x 8" / 10 x 20 cm	3.73 x 7.69 inches / 94.8 x 195.2 mm
5" x 7" / 13 x 18 cm	4.73 x 6.69 inches / 120.2 x 169.8 mm
8" x 10" / 2 x 25 cm	7.73 x 9.69 inches / 196.4 x 246.0 mm
Wide	3.73 x 6.80 inches / 94.8 x 172.6 mm

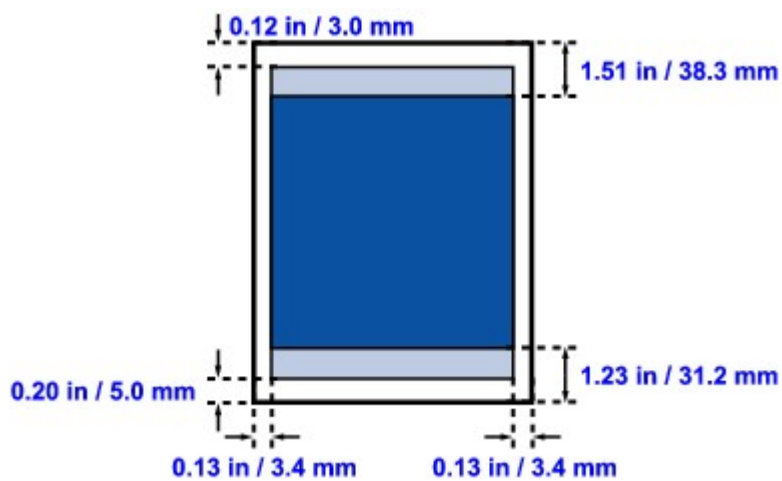

 Recommended printing area

 Printable area

[Page top](#) ↑

**Advanced Guide**

Advanced Guide &gt; Appendix &gt; Printing Area &gt; Letter, Legal

**Letter, Legal**

Size	Printable Area (width x height)
Letter	8.00 x 10.69 inches / 203.2 x 271.4 mm
Legal	8.00 x 13.69 inches / 203.2 x 347.6 mm

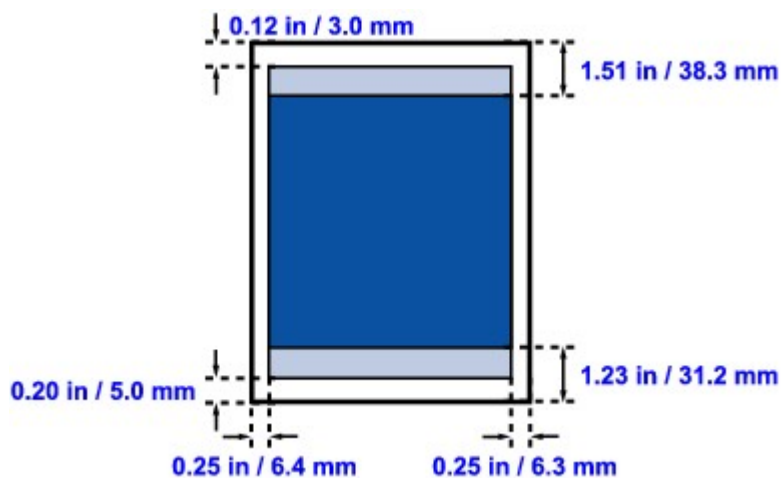
 Recommended printing area Printable area[Page top ↕](#)

## Advanced Guide

Advanced Guide > Appendix > Printing Area > Envelopes

### Envelopes

Size	Recommended Printing Area (width x height)
European DL*	4.06 x 7.12 inches / 103.2 x 180.8 mm
US Comm. Env. #10*	3.86 x 7.96 inches / 98.0 x 202.1 mm

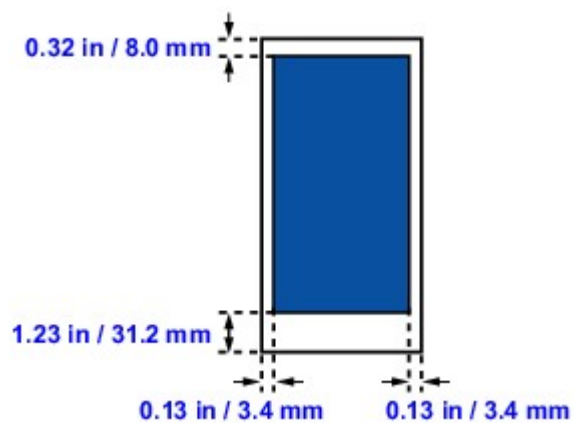

 Recommended printing area

[Page top](#) ↕



## Advanced Guide

Advanced Guide > Appendix > Deleting the Undesired Print Jobs

# Deleting the Undesired Print Jobs

If the printer does not start printing, the print job data cancelled or failed may be remaining. Delete the undesired print job by using the Canon IJ Status Monitor.

### 1. Display the Canon IJ Status Monitor

Click the Status Monitor button displayed on the Task Bar.  
The Canon IJ Status Monitor appears.

### 2. Display the print jobs

Click Display Print Queue....  
The Print Queue window opens.

### 3. Delete the print jobs

Select Cancel All Documents from the Printer menu.  
When the confirmation message appears, click Yes.

The print job is deleted.

#### Important

- Users who have not been granted access permission for printer management cannot delete the print job of another user.

[Page top](#) ↑

## Advanced Guide

[Advanced Guide](#) > [Appendix](#) > [Updating the Printer Driver](#)

---

### Updating the Printer Driver

- ➔ [Obtaining the Latest Printer Driver](#)
- ➔ [Uninstalling the Printer Driver](#)
- ➔ [Before Installing the Printer Driver](#)
- ➔ [Installing the Printer Driver](#)

[Page top](#) ↑

## Advanced Guide

[Advanced Guide](#) > [Appendix](#) > [Updating the Printer Driver](#) > [Obtaining the Latest Printer Driver](#)

# Obtaining the Latest Printer Driver

By updating the printer driver to the latest version of the printer driver, unresolved problems may be solved.

You can check the version of the printer driver by clicking the About... button on the Maintenance tab.

Access our web site through the Internet and download the latest printer driver for your model.

### Important

- You can download the printer driver for free, but any Internet access charges incurred are your responsibility.
- Before installing the latest printer driver, delete the previously installed version. For information on how to delete the printer driver, refer to [Uninstalling the Printer Driver](#).

### Related Topics

- ➔ [Before Installing the Printer Driver](#)
- ➔ [Installing the Printer Driver](#)

[Page top](#) ↑

## Advanced Guide

Advanced Guide > Appendix > Updating the Printer Driver > Uninstalling the Printer Driver

# Uninstalling the Printer Driver

The printer driver you no longer use can be deleted.  
When deleting the printer driver, first exit all programs that are running.

The procedure to delete the unnecessary printer driver is as follows:

### If there is an uninstaller

#### 1. Start the uninstaller

- In Windows Vista or Windows XP, select the Start menu -> All Programs -> "Your model name" -> Printer Driver Uninstaller.
- In Windows 2000, select the Start menu -> Programs -> "Your model name" -> Printer Driver Uninstaller.

The Printer Driver Uninstaller dialog box is displayed.

#### Important

- In Windows Vista, a confirmation/warning dialog box may appear when installing, uninstalling or starting software.  
This dialog box appears when administrative rights are required to perform a task.  
If you are logged on to an administrator account, click Continue or Allow to continue.  
Some applications require an administrator account to continue. If you are logged on to a standard account, switch to an administrator account, and restart the operation from the beginning.

#### 2. Execute the uninstaller

Click Execute. When the confirmation message appears, click Yes.  
When all the files have been deleted, click Complete.  
The deletion of the Printer Driver is completed.

### If there is no uninstaller

If there is no uninstaller in the Start menu of Windows Vista, follow these steps:

#### 1. Select the printer to be deleted

Select the Start menu -> Control Panel -> Hardware and Sound -> Printers.  
Click the model to delete, then press the Alt key on your keyboard. On the File menu, click Delete.

#### 2. Delete the printer

If the User Account Control dialog box appears, click Continue. Then when the confirmation message appears, click Yes.  
The icon is deleted.

#### 3. Select the printer driver to be deleted

Press the Alt key. On the File menu, select Run as administrator, and then click Sever Properties....  
If the User Account Control dialog box appears, click Continue.  
Click the Drivers tab. In the Installed printer drivers list, click the printer to delete.

#### 4. Delete the printer driver

When you click Remove..., Remove Driver And Package dialog box is displayed.  
Select Remove driver and driver package, and then click OK.  
In the confirmation dialog box, click Yes.

When data collection is completed in the Remove Driver Package dialog box, click Delete.

#### 5. Click OK.

The deletion of the printer driver is complete.

 **Important**

- You may not be able to delete the printer driver properly from the Installed printer drivers list. If this happens, restart your computer, and try again.

[Page top](#) ↑

## Advanced Guide

[Advanced Guide](#) > [Appendix](#) > [Updating the Printer Driver](#) > [Before Installing the Printer Driver](#)

---

## Before Installing the Printer Driver

This section describes the items that you should check before installing the Printer Driver. You should also refer to this section if the Printer Driver cannot be installed.

### Check the printer status

- Properly connect the personal computer and the printer. For details on connection instructions, refer to the "Install the Software" in the manual: Getting Started.
- Turn off the printer.

### Check the Personal Computer Settings

- Terminate all running applications.
- In Windows Vista, log on as a user who has the administrator rights.  
In Windows XP, log on as the computer administrator.  
In Windows 2000, log on as a member of the Administrators group.



#### Note

- If an old version of the Printer Driver is already installed, first delete (uninstall) that version. For instructions on deleting the Printer Driver, see [Uninstalling the Printer Driver](#).
- 

### Related Topics

- ➔ [Obtaining the Latest Printer Driver](#)
- ➔ [Installing the Printer Driver](#)

[Page top](#) ↑

## Advanced Guide

Advanced Guide > Appendix > Updating the Printer Driver > Installing the Printer Driver

# Installing the Printer Driver

You can access our web site through the Internet and download the latest Printer Driver for your model.

The procedure for installing the downloaded Printer Driver is as follows:

## 1. Turn off the printer

### Important

- If you turn on the computer while the printer is on, the Windows Plug and Play function is executed automatically, and the Found New Hardware window (Windows Vista) or Found New Hardware Wizard window (Windows XP, Windows 2000) is displayed. In this case, click Cancel.

## 2. Start the installer

Double-click the icon of the downloaded file.  
The installation program starts.

### Important

- In Windows Vista, a confirmation/warning dialog box may appear when installing, uninstalling or starting software.  
This dialog box appears when administrative rights are required to perform a task.  
If you are logged on to an administrator account, click Continue or Allow to continue.  
Some applications require an administrator account to continue. If you are logged on to a standard account, switch to an administrator account, and restart the operation from the beginning.

## 3. Install the driver

At the Welcome window, click Next.  
Read the contents of the License Agreement window. After checking the contents, click Yes.  
Installation of the Printer Driver begins.

After the Installation Complete window is displayed, check that the printer and the computer are connected through a cable.

To select the connection port for your printer manually, check the Select printer port check box, and click Manual selection. At the Select printer port window, select the connection destination, and then click OK.

## 4. Complete the installation

Click Complete.  
Turn on the printer, and wait awhile until the connection is recognized.

This procedure installs the Printer Driver.

Depending on the environment you are using, a message prompting you to restart the computer may be displayed. To complete the installation properly, restart the computer.

### Important

- When you expand the downloaded compressed file, save the file to a folder such as "temp". Do not use the characters other than English in the folder name. Otherwise, the printer driver may not be installed correctly.
- You can download the printer driver for free, but any Internet access charges incurred are your responsibility.

## Related Topics

➔ [Obtaining the Latest Printer Driver](#)

➔ [Before Installing the Printer Driver](#)

## Advanced Guide

Advanced Guide > Appendix > Uninstalling the On-Screen Manuals

# Uninstalling the On-Screen Manuals

Follow the procedure below to uninstall all of the installed on-screen manuals from your computer.



All of the installed on-screen manuals will be deleted at the same time.

1. Click Start > All Programs (Programs in Windows 2000) > Canon XXX Manual (where "XXX" is your printer's name) > Uninstall.
2. Click OK when the confirmation message appears.



### note

- When the message prompting you to restart your computer is displayed, click OK to restart your computer.



On-screen manuals other than printer driver's help are uninstalled at a time.

1. Select Applications on the Go menu.
2. Double-click the Canon Utilities folder, and then the IJ Manual folder.
3. Drag the folder of your printer's name into the trash.
4. Drag the  XXX On-screen Manual icon (where "XXX" is your printer's name) on your desktop into the trash.



## Advanced Guide

Advanced Guide > Appendix > Transporting and Storing the Printer

# Transporting and Storing the Printer

When relocating the printer or storing the printer for a long period of time, pack the printer using the original packing materials.

If you do not have the original packing materials, pack the printer carefully using protective material and place it inside a sturdy box.

### **caution**

- Do not transport or store the printer slanted, vertically, or upside-down, as the ink may leak and damage the printer.

1. Turn the printer off.
2. Confirm that the **Power** lamp is off and unplug the printer.

### **important**

- Do not unplug the printer while the **Power** lamp is lit or flashing green, as it may cause malfunction or damage to the printer, making the printer unable to print.

3. Close the Paper Support.
4. Disconnect the printer cable from the computer and from the printer, and then disconnect the power plug from the printer.
5. Use adhesive tape to secure all the covers on the printer to keep them from opening during transportation. Then pack the printer in the plastic bag.
6. Attach the protective material to the printer when packing the printer.

### **important**

- Pack the printer with the FINE Cartridges left installed in the printer.

### **note**

- Clearly label the box as "FRAGILE" or "HANDLE WITH CARE".

## Advanced Guide

Advanced Guide > Appendix > Opening the Printer Properties Dialog Box (Windows)

# Opening the Printer Properties Dialog Box (Windows)

The printer driver setup window can be displayed through the application software in use or the Start menu of the Windows.

## Open the Printer Properties Dialog Box through the Application Software

Follow the procedure below to configure print settings when printing.

### 1. Select the command you perform printing on the application software in use.

In general, select Print on the File menu to open the Print dialog box.

### 2. Select your model name and click Preferences (or Properties).

The printer properties dialog box opens.



#### note

- Opening the printer properties dialog box through Properties displays such tabs regarding the Windows functions as the Ports (or Advanced) tab. Those tabs do not appear when opening through Printing Preferences or application software. About tabs regarding Windows functions, refer to the user's manual for the Windows.

## Open the Printer Properties Dialog Box through the Start Menu

Follow the procedure below to perform maintenance operations such as print head cleaning, or to configure print settings that are common for all application software.

### 1. Select items from the Start menu as shown below.

- In Windows Vista, select the Start menu > Control Panel > Hardware and Sound > Printers.
- In Windows XP, select the Start menu > Control Panel > Printers and Other Hardware > Printers and Faxes.
- In Windows 2000, select the Start menu > Settings > Printers.

### 2. Right-click your model name icon, and then select Printing Preferences from the displayed menu.

The printer properties dialog box opens.



#### important

- Depending on application software you use, command names or menu names may vary and there may be more steps. For details, refer to the user's manual of your application software.

## Advanced Guide

Advanced Guide > Appendix > Opening the Page Setup and Print Dialog Box (Macintosh)

# Opening the Page Setup and Print Dialog Box (Macintosh)

You can open the Page Setup dialog box and the Print dialog box from the application program you are using.

## Opening the Page Setup Dialog Box

Open the Page Setup dialog box to specify page (paper) settings before printing.

- 1. Select Page Setup... on the File menu in your application program.**

The Page Setup dialog box opens.

## Opening the Print Dialog Box

Open the Print dialog box to specify print settings before printing.

- 1. Select Print... on the File menu in your application program.**

The Print dialog box opens.

[Page top](#) ↕

## Advanced Guide

Advanced Guide > Appendix > Opening the Canon IJ Printer Utility (Macintosh)

### Opening the Canon IJ Printer Utility (Macintosh)

To open the Canon IJ Printer Utility, follow the procedure below.

#### In Mac OS X v.10.5.x

1. Select System Preferences on the Apple menu.
2. Click Print & Fax.
3. Select your printer's name in the Printers and click Open Print Queue....  
The job list of your printer is displayed.
4. Click Utility.

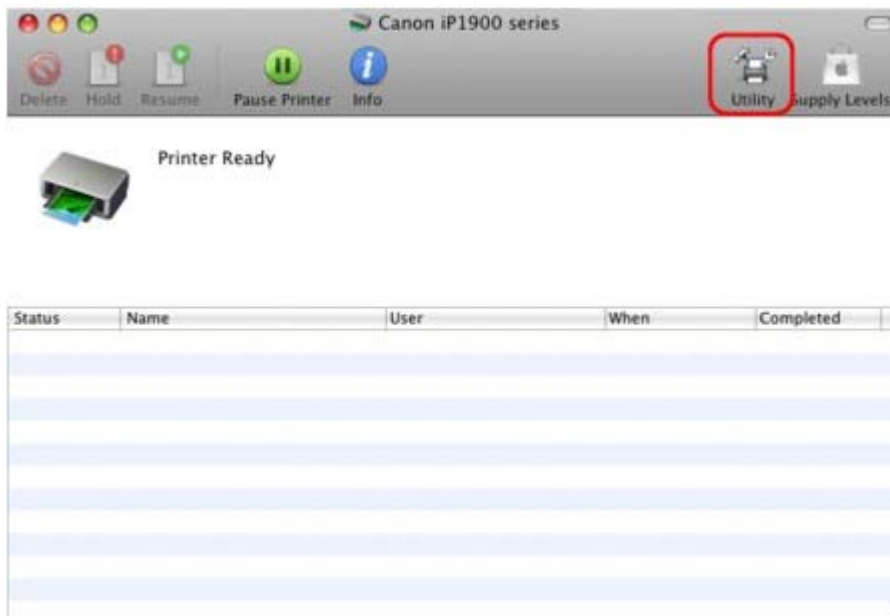

The **Printer List** opens.

5. Select your printer's name in the Product list and click Maintenance.

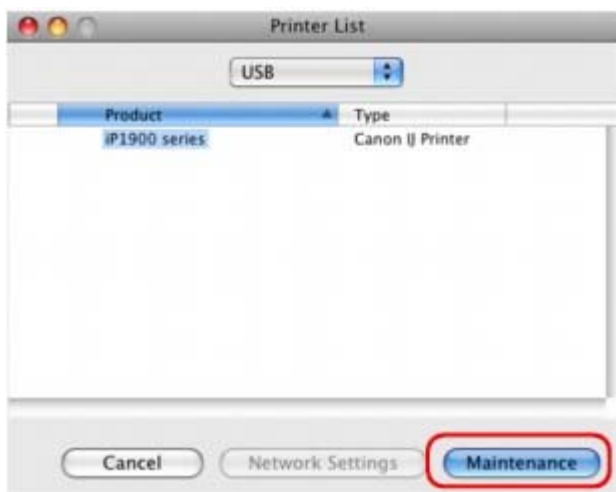

The Canon IJ Printer Utility starts up.

#### In Mac OS X v.10.4.x or Mac OS X v 10.3.9

1. Select Applications on the Go menu.
2. Double-click the Utilities folder, and then double-click the Printer Setup Utility icon.  
The Printer List opens.
3. Select your printer's name in the Name list and click Utility.

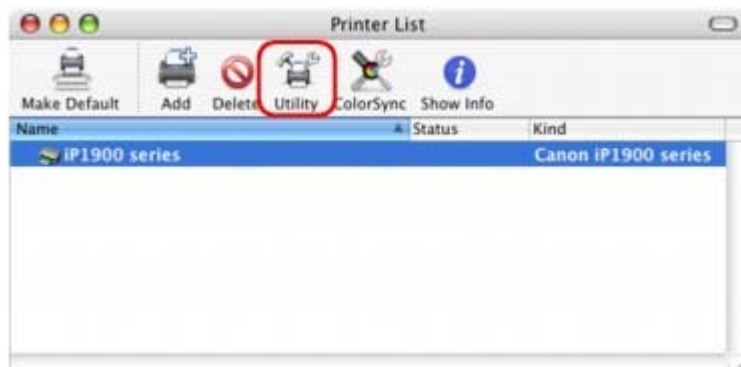

4. Select your printer's name in the Product list and click Maintenance.

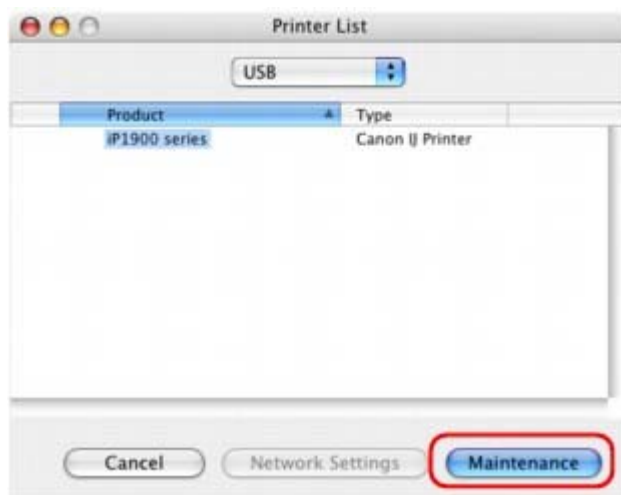

The Canon IJ Printer Utility starts up.

## Advanced Guide

Advanced Guide > Appendix > Connecting the Printer to the Network

# Connecting the Printer to the Network

If multiple computers are being used in the network environment, you can share the printer connected to one computer with other computers.

The Windows versions of the computers connected to the network do not necessarily have to be the same.

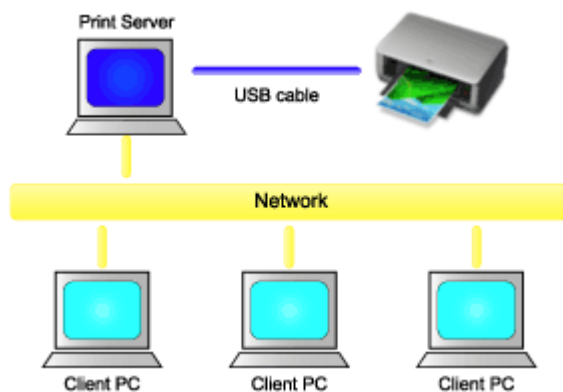

- **Settings on Print Server**

Describes the procedure for setting up a computer directly connected to a printer with a USB cable.

- **Settings on Client PC**

Describes the procedure for setting up those computers that will use this printer through the network.

When you execute print, the data is sent through the print server system to the printer.

### Important

- In case an error occurred when a document is printed by the client system to a shared printer, the error message of Canon IJ Status Monitor will be displayed both on the client system and the print server system. For regular printing, Canon IJ Status Monitor will be displayed only on the client system.

### Note

- Install the printer driver from the Setup CD-ROM that accompanies the printer on the print server system and each of the client systems according to the OS of each system.

### Related Topic

➔ [Restrictions on Network Printing](#)



[Page top](#) ↑

## Advanced Guide

Advanced Guide > Appendix > Connecting the Printer to the Network > Settings on Print Server

# Settings on Print Server

To use a printer in a network, set printer sharing on the print server system.

The procedure for setting up the print server systems is as follows:

## 1. Install the printer driver on the print server system

For installation instructions, see the user's manual.

## 2. Select items from the Start menu as shown below:

- In Windows Vista, select the Start menu -> Control Panel -> Hardware and Sound -> Printers.
- In Windows XP, select the Start menu -> Control Panel -> Printers and Other Hardware -> Printers and Faxes.
- In Windows 2000, select the Start menu -> Settings -> Printers.

The Printers window (Windows Vista, Windows 2000) or Printers and Faxes window (Windows XP) is displayed.

## 3. Click the icon for the model name of printer to be shared

- In Windows Vista, press the Alt key on your keyboard and then select Run as administrator -> Sharing... from the displayed File menu.
- In Windows XP or Windows 2000, select Sharing... from the File menu.



### Note

- Windows XP may display a message recommending the user to use the Network Setup Wizard to set up sharing. When this message appears, choose not to use the wizard and then set up sharing.

## 4. Set sharing

Select Share this printer (Windows Vista, Windows XP) or Shared as (Windows 2000) on the Sharing tab to set a shared name as desired, and click OK.



### Important

- In Windows Vista, a confirmation/warning dialog box may appear when installing, uninstalling, or starting software. This dialog box appears when administrative rights are required to perform a task. If you are logged on to an administrator account, click Continue or Allow to continue. Some applications require an administrator account to continue. If you are logged on to a standard account, switch to an administrator account, and restart the operation from the beginning.

This completes the setup on the print server system. Next, set up the client systems.



## Advanced Guide

Advanced Guide > Appendix > Connecting the Printer to the Network > Settings on Client PC

# Settings on Client PC

After setting up the print server system, set up the client system.

The procedure for setting up the client systems is as follows:

## In Windows Vista

### 1. Install the printer driver on the client systems

Select Custom Install for the installation method.

For details on connection instructions, refer to the "Install the Software" in the manual: Getting Started.



#### Note

- During the installation, a screen prompting you to turn the printer on appears. Click Manual Selection and then select an appropriate port to complete your installation.

### 2. Start the wizard

Select the Start menu -> Network -> Add a printer.

The Add Printer window appears.

### 3. Add a printer

Select Add a network, wireless or Bluetooth printer, and click the icon for the printer that you have configured on the print server system to be shared, and then click Next.



#### Note

- If the icon for the printer is not displayed, check that the printer is actually connected to the print server.
- It may take some time for the icon for the printer to appear.

### 4. Complete the setup

Take the appropriate action as described on the screen and then click Finish.

The icon for the shared printer will be created in the Printers window.

This completes the setup on the client systems. You can now share the printer in the network.

## In Windows XP/Windows 2000

### 1. Install the printer driver on the client systems

Select Custom Install for the installation method.

For details on connection instructions, refer to the "Install the Software" in the manual: Getting Started.



#### Note

- During the installation, a screen prompting you to turn the printer on appears. Click Manual Selection and then select an appropriate port to complete your installation.

### 2. Start the wizard

- In Windows XP, select the Start menu -> Control Panel -> Printers and Other Hardware -> Printers and Faxes -> Add a printer.

- In Windows 2000, select the Start menu -> Settings -> Printers -> Add a printer.

When Welcome to the Add Printer Wizard screen appears, click Next.

### 3. Add a printer



Select A network printer, or a printer attached to another computer (Windows XP) or Network printer (Windows 2000), then click Next.

On the Specify a Printer window (Windows XP) or Locate Your Printer window (Windows 2000), click Next and then search for the print server system.

Click the icon for the printer that you have configured on the print server system to be shared, and then click Next.

**Note**

- If the icon for the printer is not displayed, check that the printer is actually connected to the print server.

#### 4. Complete the setup

Take the appropriate action as described on the screen and then click Finish.

The icon for the shared printer will be created in the Printers and Faxes window (Windows XP) or Printers window (Windows 2000).

This completes the setup on the client systems. You can now share the printer in the network.



## Advanced Guide

Advanced Guide > Appendix > Connecting the Printer to the Network > Restrictions on Network Printing

# Restrictions on Network Printing

These are restrictions that apply if you are using a printer in a network environment. Check the restrictions for the environment you are using.

### If you are sharing a printer in a network

- A print completion message may be displayed. To disable the message display, follow the procedure below.
  - **In Windows Vista:**  
Press the Alt key from the Printers window on the client system. Open Run as administrator -> Server Properties... from the displayed File menu.  
Uncheck Show informational notifications for network printers on the Advanced tab, and then restart the computer.
  - **In Windows XP or Windows 2000:**  
Open Server Properties from the File menu of the Printer and Faxes window (Windows XP) or the Printers window (Windows 2000) on the print server system.  
Uncheck Notify when remote documents are printed on the Advanced tab, and then restart the computer.
- The bi-directional communication function is disabled so that the correct printer status may not be recognized.  
If a client user opens the printer driver properties and then clicks OK with the Enable bidirectional support check box on the Ports tab unchecked, the bi-directional function of the printer server system may also be disabled.  
In this case, check Enable bidirectional support check box on both the print server system and the client system.
- When you print from a client system, you cannot use Canon IJ Preview.
- If the functions on the Maintenance tab cannot be set properly from a client system, they may be grayed out. In this case, change the settings from the print server.  
When you change the settings of the print server, you should delete the icon of the shared printer from the client system, and then specify the shared settings again in the client system.

### If the same printer driver is installed in the print server system and the client system as the local printer

- The net crawl function may automatically create a network printer icon on the client system.



## Advanced Guide

Advanced Guide > Using Easy-PhotoPrint EX

# Using Easy-PhotoPrint EX

## --- Transforming Your Photos into Creative Works of Art ---

Easy-PhotoPrint EX allows you to create albums, calendars and stickers easily using photos taken with digital cameras.

You can also print borderless photos easily.

## Start Easy-PhotoPrint EX



Click Here: [Easy-PhotoPrint EX](#)



### Note

- See the section below for details on how to use Easy-PhotoPrint EX.  
 ➔ [Printing with the Bundled Application Software](#)

## Create a Personalized Photo Album

Creating a personalized photo album is an easy task if you use Easy-PhotoPrint EX!

All you need to do is select which photos to use, select a layout, then load paper into your printer and print. After you bind the printed sheets, you'll have the one and only album of your memories!



You can change the layout and background, and attach comments to photos.



You can also select the size and orientation.



You can arrange a photo across the left and right pages.

CHECK! .....

Select a theme (background design) to create a single-themed album.

## Decorate Items with Text and Frames

You can add text and frames to photos. Attach a description of the photo in an album, and add a frame to enhance the photo's atmosphere.



CHECK! .....

Select Album to add text and frames. You cannot decorate photos with Photo Print.

### Create a Calendar Using Your Favorite Photos

Create calendars easily with Easy-PhotoPrint EX. Create your own calendar using your favorite photos! It'll be exciting to turn the calendar pages.



You can use all kinds of photos.

You can also create 2-month, 6-month and 12-month calendars.

### Create Stickers

Create stickers easily with Easy-PhotoPrint EX!

Create stickers of your favorite photos and share them with your friends!



CHECK! .....

You can add text to photos.

## Advanced Guide

Advanced Guide > About Solution Menu

# About Solution Menu

## Quick Shortcut!! Solution Menu

Solution Menu is a menu window that provides quick access from your desktop to Canon applications, manuals, and online product information.

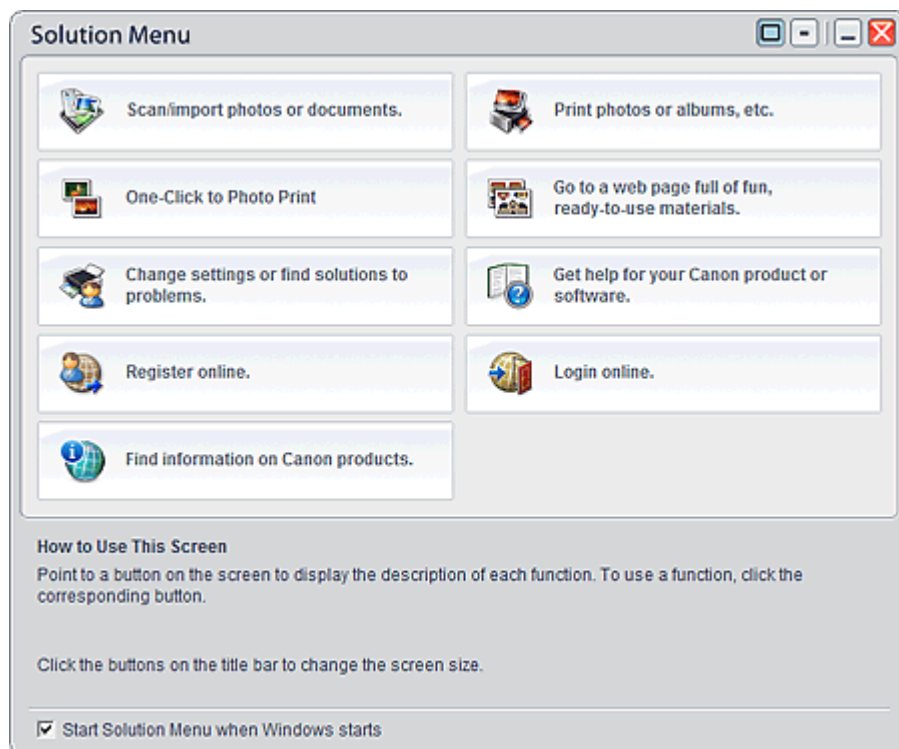

### Important

- The number and types of buttons displayed in the window may vary depending on your printer and region.

## Starting Solution Menu

 Click Here: [Solution Menu](#)

To start from desktop, see below.

Double-click the Solution Menu icon on the desktop. Alternatively, from the Start menu, select (All) Programs > Canon Utilities > Solution Menu > Solution Menu.



From the next time, Solution Menu starts when Windows starts.

If the Start Solution Menu when Windows starts checkbox at the bottom left of the window is not selected, Solution Menu does not start when Windows starts.

### Important

- Solution Menu will start automatically when you install it using the Setup CD-ROM that accompanies the printer.

## Changing the Window Size

Click  (window size: large) or  (window size: small) on the title bar to change the window size (large or small).

Solution Menu opens with the last used window size next time it is started.

- When screen size is small

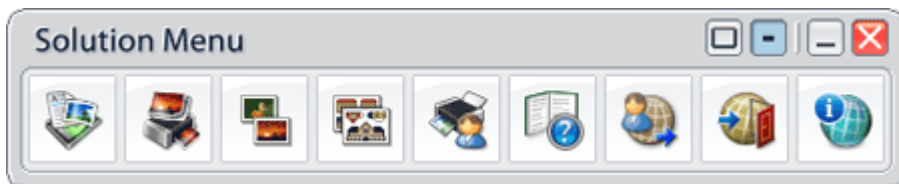

### Starting an Application

1. Point to a button on the window to display the description of each application.
2. By clicking each button, the introduced application starts.  
Follow the same steps to view the manuals or online product information.

#### Important

- Internet connection is required to access the online information. Internet connection fees apply.

### Exiting Solution Menu

Click  (Close) on the title bar.

### Restriction on Use of Solution Menu

This software is subject to the following restriction. Keep this point in mind when using it.

- All icons of the installed applications that support Solution Menu are displayed in the window. After the installation, you cannot rearrange the icons or delete only the icons.

[Page top](#)↑