

ENGLISH

**Canon**

***PowerShot A470***

**Camera User Guide**



Getting Started

p. 7

Ensure that you read the Safety Precautions (pp. 144–148)

DiG!C III



PictBridge



DIRECT  
PRINT



BUBBLE JET  
DIRECT









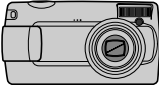

Exif Print



DPOF

# Confirming the Package Contents

The following items are included in the package. If something is missing please contact the retail outlet at which you purchased the product.

- |          |  |          |   |          |  |
|----------|--|----------|---|----------|--|
| <b>1</b> | <b>Camera</b><br>                             | <b>2</b> | <b>AA-size Alkaline Batteries (x2)</b><br> | <b>3</b> | <b>Memory Card (32MB)</b><br> |
| <b>4</b> | <b>Interface Cable IFC-400PCU</b><br>         | <b>5</b> | <b>AV Cable AVC-DC300</b><br>              | <b>6</b> | <b>Wrist Strap WS-800</b><br> |
| <b>7</b> | <b>Canon Digital Camera Solution Disk</b><br> | <b>8</b> | <b>EWS Booklet</b><br>                     |          |  |
| <b>9</b> | <b>User Guides</b><br> <b>Getting Started</b> |          |  <b>Canon Digital Camera Manuals Disk</b>  |          |  |

You may not be able to achieve the full performance of this camera with the included memory card.



You can use SD memory cards, SDHC (SD High Capacity) memory cards, MultiMediaCards, MMCplus cards and HC MMCplus cards in this camera. These cards are collectively referred to as memory cards in this guide.

## Viewing the PDF Manuals



Adobe Reader must be installed to view the PDF Manuals. If this software is not installed in your computer, access the following web site and download the software.

<http://www.adobe.com>

# Let's Get Started!

First...

Getting Started

p. 7

This section explains how to prepare the camera for use and the basics of shooting, viewing and printing images. Start out by familiarizing yourself with the camera and mastering the basics.

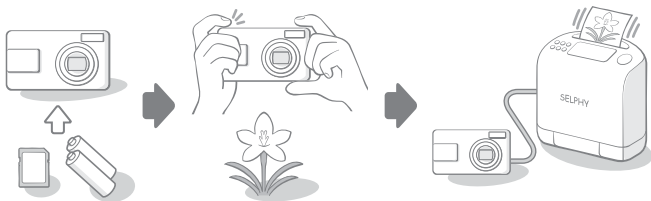

Next...

PDF Manuals



Once you have mastered the basics, use the camera's many features to shoot more challenging photos.

The PDF manuals are included in the supplied CD-ROM.

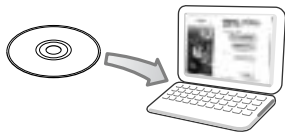



Adobe Reader is required to view the PDF manuals.  
Please download from <http://www.adobe.com>

# Table of Contents

Items marked with a ☆ are lists or charts that summarize camera functions or procedures.





## Please Read





6

<b>Getting Started</b> .....	<b>7</b>
Preparations .....	9
Shooting Still Images (  Auto Mode) .....	14
Viewing Still Images .....	16
Erasing .....	17
Printing .....	18
Embedding the Date in the Image Data .....	20
Shooting Movies (  Standard Mode) .....	22
Viewing Movies .....	24
Downloading Images to a Computer .....	25
System Map .....	32

## Learning More .....

37

<b>Components Guide</b> .....	<b>38</b>
Indicator .....	41
<b>Basic Operations</b> .....	<b>42</b>
☆ Menus and Settings .....	42
☆ Information Displayed on the LCD Monitor and Menus .....	44
Using the LCD Monitor .....	51
<b>Commonly Used Shooting Functions</b> .....	<b>54</b>
  Shooting with the Optical Zoom .....	54
Using the Digital Zoom/Digital Tele-Converter .....	55
 Using the Flash .....	59
  Shooting Close-ups/Infinity Shots (Macro/Infinity/ Super Macro) .....	60
Using the Self-Timer .....	62
Changing the Recording Pixels (Still Images) .....	64
Changing the Compression (Still Images) .....	65

<b>Various Shooting Methods</b>	<b>66</b>
 Shooting Modes for Specific Scenes	66
 Shooting in Manual Mode	68
Continuous Shooting	69
Setting the Flash	70
 Movie Shooting	72
Checking the Focus and People's Expressions	75
Selecting an AF Frame Mode	76
Selecting the Face to Focus On (Face Select and Track)	78
Shooting Hard-to-Focus Subjects (Focus Lock)	80
Adjusting the ISO Speed	81
Adjusting the Exposure Compensation	82
Switching between Metering Modes	83
Setting a Slow Shutter Speed (Long Shutter Mode)	84
Adjusting the Tone (White Balance)	86
Shooting in a My Colors Mode	89
Setting the Display Overlays	91
Categorizing Images Automatically (Auto Category)	92
 Registering Settings to the Print/Share Button	93
<b>Playback/Erasing</b>	<b>96</b>
 Viewing Magnified Images	96
Viewing Images in Sets of Nine (Index Playback)	97
Organizing Images by Category (My Category)	98
Jumping to Images	99
Viewing Movies	100
Rotating Images in the Display	102
Playback with Transition Effects	103
Automated Playback (Slide Show)	104
Red-Eye Correction Function	105
Resizing Images	110
Attaching Sound Memos to Images	112
Protecting Images	113
Erasing All Images	114

<b>Print Settings/Transfer Settings</b>	<b>115</b>
Setting the DPOF Print Settings . . . . .	115
Setting the DPOF Transfer Settings . . . . .	119
<b>Configuring the Camera</b>	<b>121</b>
Setting the Power Saving Function . . . . .	121
Formatting Memory Cards . . . . .	122
Resetting the File Number . . . . .	123
Creating an Image Destination (Folder). . . . .	125
Setting the Auto Rotate Function. . . . .	127
Resetting Settings to Their Default Values . . . . .	128
<b>Connecting to a TV</b>	<b>129</b>
Shooting/Playback Using a TV . . . . .	129
<b>Troubleshooting</b>	<b>130</b>
<b>List of Messages</b>	<b>140</b>
<b>Appendix</b>	<b>144</b>
Safety Precautions. . . . .	144
Handling Precautions. . . . .	150
Using the Power Kits (Sold Separately). . . . .	154
Using an Externally Mounted Flash (Sold Separately) . . .	157
Replacing the Date Battery . . . . .	159
Camera Care and Maintenance. . . . .	161
Specifications. . . . .	162
<b>Index</b>	<b>172</b>
 <b>Functions Available in Each Shooting Mode</b>	<b>176</b>

## About this Guide

### ■ Symbol Conventions in this Guide

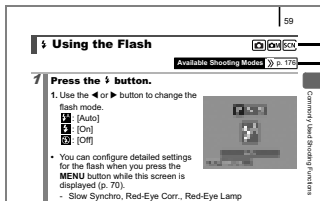

Mode dial position

Some functions may not be available in certain shooting modes. If there is no notation to that effect, the function may be used in all modes.



This mark denotes issues that may affect the camera's operation.



This mark denotes additional topics that complement the basic operating procedures.

Explanations in this guide are based on the camera's default settings at time of purchase. Specifications are subject to change without prior notice. As a result, the illustrations and screenshots used in this guide may differ from the actual camera.

# Please Read

## Test Shots

Before you try to photograph important subjects, we highly recommend that you shoot several trial images to confirm that the camera is operating and being operated correctly.

Please note that Canon Inc., its subsidiaries and affiliates, and its distributors are not liable for any consequential damages arising from any malfunction of a camera or accessory, including memory cards, that results in the failure of an image to be recorded or to be recorded in a way that is machine readable.

## Warning Against Copyright Infringement

Please note that Canon digital cameras are intended for personal use and should never be used in a manner that infringes upon or contravenes international or domestic copyright laws and regulations. Please be advised that in certain cases the copying of images from performances, exhibitions, or commercial properties by means of a camera or other device may contravene copyright or other legal rights even if the image was shot for personal use.

## Warranty Limitations

For information on your camera's warranty, please refer to the Canon European Warranty System (EWS) Booklet supplied with your camera.

**For Canon Customer Support contacts, please refer to the Canon European Warranty System (EWS) Booklet supplied with your camera.**

### Camera Body Temperature

---

If your camera is used for prolonged periods, the camera body may become warm. Please be aware of this and take care when operating the camera for an extended period.

### About the LCD Monitor

---

The LCD monitor is produced with extremely high-precision manufacturing techniques. More than 99.99% of the pixels operate to specification. Less than 0.01% of the pixels may occasionally misfire or appear as red or black dots. This has no effect on the recorded image and does not constitute a malfunction.

## Video Format

Please set the camera's video signal format to the one used in your region before using it with a TV monitor.

## Language Setting

Please see *Setting the Display Language* (p. 13) to change the language setting.



# Getting Started

- **Preparations**
- **Shooting Still Images**
- **Viewing Still Images**
- **Erasing**
- **Printing**
- **Embedding the Date in the Image Data**
- **Shooting Movies**
- **Viewing Movies**
- **Downloading Images to a Computer**
- **System Map**



## Capture Your Best Memories

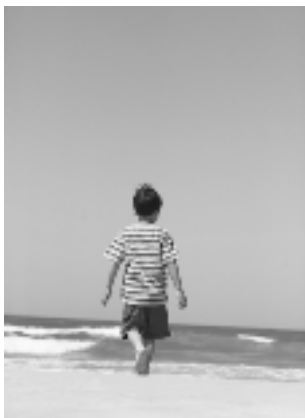

## Preparations

### Installing the Batteries and Memory Card

- 1 Slide the battery cover lock in the direction of the arrow (①) and hold it there while moving the entire cover in the direction of the arrow (②) and opening it up in the direction of the arrow (③).

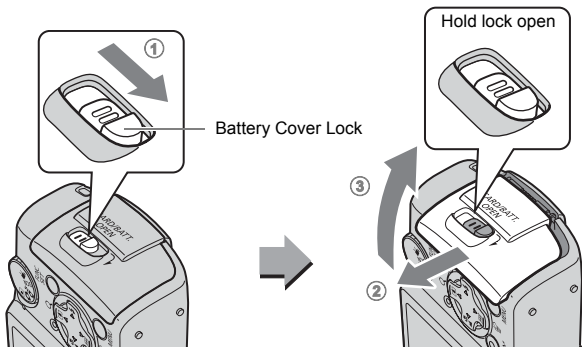

Be sure to hold the battery cover lock open while sliding the entire cover in the direction of the arrow.

Hold lock open

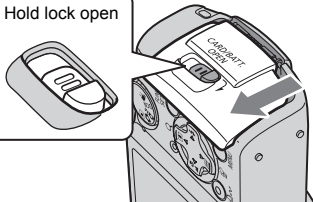

## 2 Install two batteries.

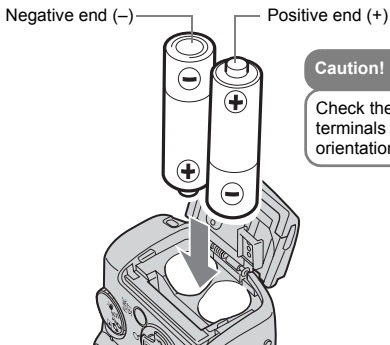

### Caution!

Check the battery terminals for the correct orientation.

## 3 Insert the memory card until it clicks into place.

### Caution!

Check the memory card for the correct orientation.

### Only SD and SDHC memory cards

Write Protect Tab

Confirm that the write protect tab is unlocked.

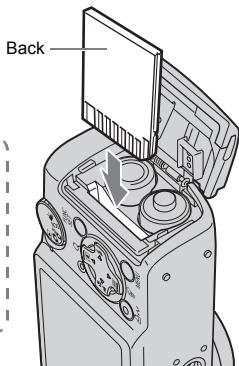

The camera may fail to detect the memory card or malfunction if the memory card is inserted backward by mistake.

- 4 Close the cover (①), and press downward as you slide it until it clicks into place (②).

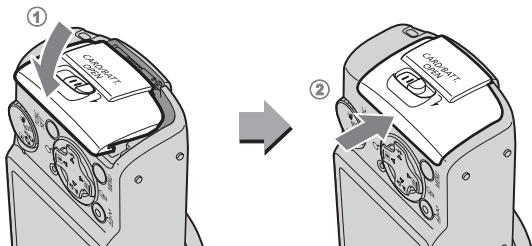

### To Remove the Memory Card

- Push the memory card with your finger until the memory card clicks and then release it.

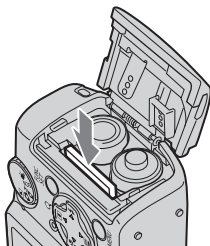

It is recommended to use the wrist strap to avoid dropping the camera during use.

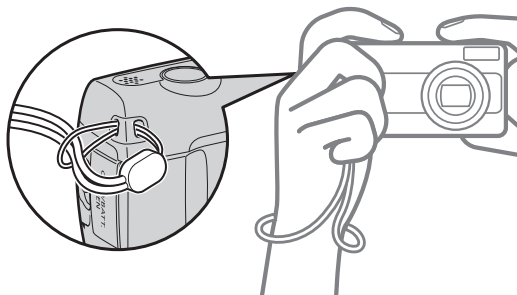

## Setting the Date and Time

The Date/Time settings menu will appear the first time the power is turned on.

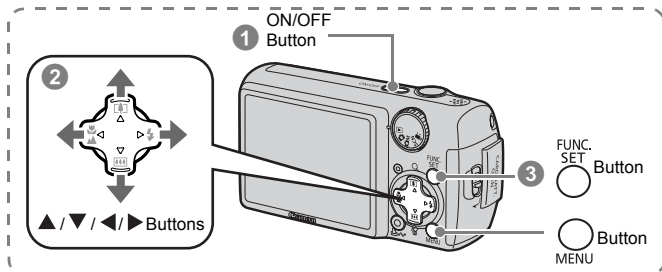

- 1 Press the ON/OFF button.
- 2 Select the month, day, year and time, and the display order.
  1. Use the ◀ or ▶ button to select a category.
  2. Use the ▲ or ▼ button to set the value.
- 3 Press the FUNC./SET button.



### ■ To Change a Previously Set Date/Time

Perform Steps 2–3 above after using the following procedures to display the Date/Time settings window.



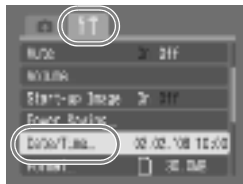

1. Press the MENU button.
2. Use the ◀ or ▶ button to select the **[T]** (Set up) menu.
3. Use the ▲ or ▼ button to select [Date/Time].
4. Press the FUNC./SET button.
5. Press the MENU button.

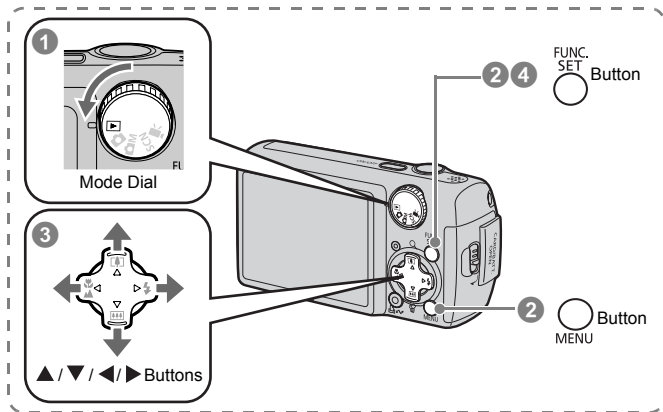

## Setting the Display Language

You can change the language displayed in the LCD monitor menus and messages.



- 1 Set the mode dial to  (Playback).
- 2 Hold down the FUNC./SET button and press the MENU button once.
- 3 Use the , ,  or  button to select a language.
- 4 Press the FUNC./SET button.

## Shooting Still Images (📷 Auto Mode)

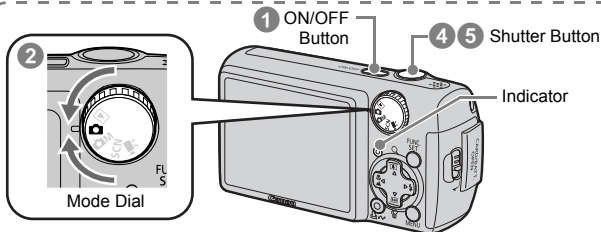

### 1 Press the ON/OFF button.

- The start-up sound will play and the start-up image will display in the LCD monitor.
- Pressing the ON/OFF button again turns the power off.
- To switch to the setting that mutes all sound, press and hold the **MENU** button while pressing the ON/OFF button. The [Mute] setting also can be changed in the **11** (Set up) menu.

### 2 Select a shooting mode.

1. Set the mode dial to 📷 (Auto).



### 3 Aim the camera at the subject.

#### Avoiding Camera Shake

Keep your arms tight against your body while holding the camera firmly by the sides. Using a tripod is also effective.



### 4 Press the shutter button lightly (press halfway) to set the focus.

- When the camera focuses, it beeps twice and the indicator lights green (orange when the flash fires).



## 5 Without changing anything else, press the shutter button all the way (press fully) to shoot.

- The shutter sound will play once and the image will record.
- Recorded images are displayed on the LCD monitor for approximately 2 seconds\* immediately after shooting (Rec. Review). You can also shoot while the image is displayed.
- \* You can change the interval for which images are displayed by configuring the [Review] item in the  (Rec.) menu.
- The image will continue to display after shooting if you keep the shutter button pressed.
- The indicator will blink green and the file will record to the memory card.

### To Shoot Images in Focus

The camera automatically sets the focus when you press the shutter button halfway\*.

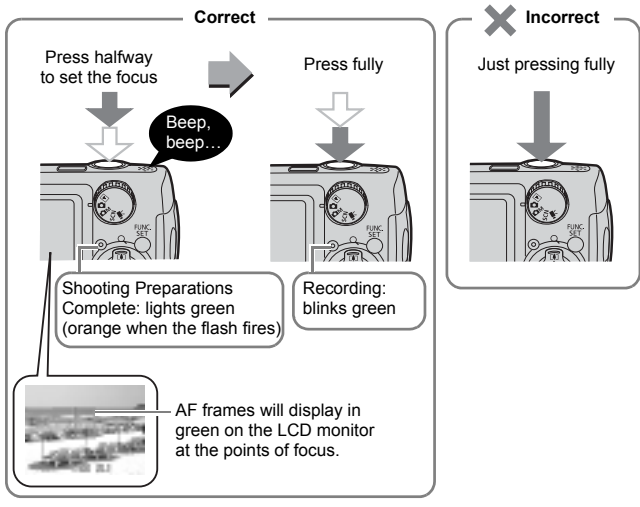

\* The shutter button has a two-stage action. Pressing it down to the first stage is referred as “pressing halfway”.



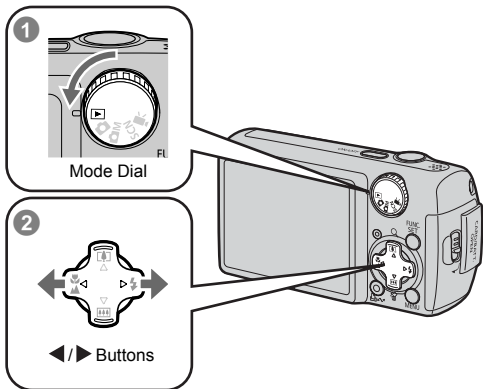

## Viewing Still Images



1 Set the mode dial to  (Playback).

2 Use the  or  button to display the image you wish to view.

- Use the  button to move to the previous image and the  button to move to the next image.
- The images advance more quickly if you keep the button pressed continuously, but they will appear coarse.



- Setting [Resume] to either [Last seen]\* or [Last shot] in the  (Play) menu allows you to specify the image to display in Playback mode (\* Default setting). If you select [Last seen], the last image viewed will display (Resume Playback).
- The following actions will display the most recent image regardless of the [Resume] settings.  
Shooting an image, changing the memory card, or editing an image on the memory card using a computer.

# Erasing

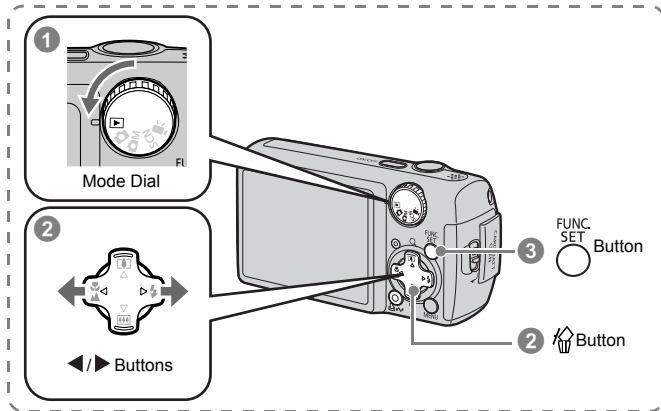

- 1 Set the mode dial to (Playback).
- 2 Use the or button to select an image to erase and press the button.
- 3 Confirm that [Erase] is selected and press the FUNC./SET button.
  - To exit instead of erasing, select [Cancel].



Please note that erased images cannot be recovered. Exercise adequate caution before erasing an image.

# Printing

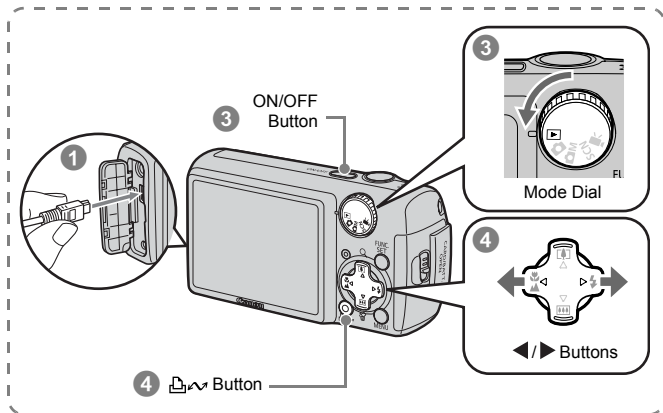

## 1 Connect the camera to a direct print compatible printer.

- Open the camera's terminal cover and insert the interface cable all the way into the connector.
- See the printer's user guide for connection instructions.
- Since this camera uses a standard protocol (PictBridge), you can use it with other PictBridge-compliant printers in addition to Canon-brand printers. Please see the *Direct Print User Guide* for more information.

## 2 Turn on the printer.

## 3 Set the camera's mode dial to (Playback) and press the ON/OFF button.

- The  button will light blue.

## 4 Use the or button to select an image to print and press the button.

- The  button will blink blue and printing will start.

## Printing From a Print List



You can add images directly to a print list by merely pressing the  button immediately after shooting or playing back an image. You can then print the images from the print list easily, when connecting the camera to a printer.

### Adding to a Print List



1 Press the  button (still images only).

2 Add to the print list.

1. Use the  or  button to set the number of copies to print.

2. Use the  or  button to select [Add].

3. Press the **FUNC./SET** button.

- To remove an image from the print list, press the  button again, use the  or  button to select [Remove] and press the **FUNC./SET** button.





### Printing Images in a Print List



This explanation is based on the use of a Canon SELPHY ES series or SELPHY CP series printer.

1 Connect the camera to a printer.

Number of copies to print

2 Print.

1. Use the  or  button to select [Print now].

- You can use the  or  button to confirm the images added to the print list.

2. Press the **FUNC./SET** button.

- Printing will start.
- If printing is halted and resumed, printing will start from the next image in the queue.



## Embedding the Date in the Image Data

This section explains how to embed date information on images as they are recorded (Date Stamp).

- The date stamp cannot be deleted from the image data once it has been embedded. Ensure that the camera's date/time is set correctly beforehand (p. 12).
- The image size is fixed to the 2M (1600 x 1200) setting and the compression to Fine (appropriate for printing L-size or postcard-size prints).

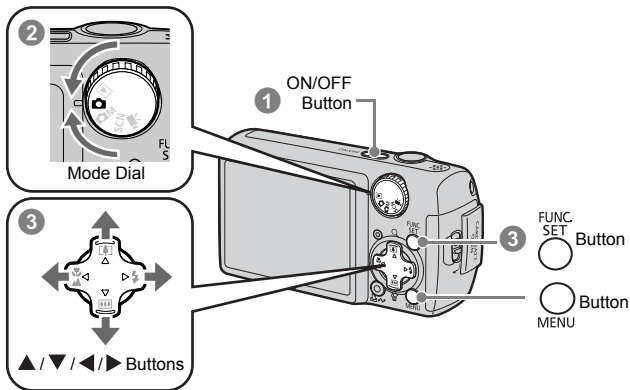

- 1 Press the ON/OFF button.
- 2 Set the mode dial to (Auto).
  - You can also make this setting in M or SCN mode.

### 3 Select (Date Stamp).

1. Press the FUNC./SET button.
2. Use the ▲ or ▼ button to select .



3. Use the ◀ or ▶ button to select .

- The area that will not print displays in gray.
- Pressing the **MENU** button allows you to switch to [Date & Time] using the ◀ or ▶ button.





You can use the following methods to imprint the date on images lacking imprinted date stamps.

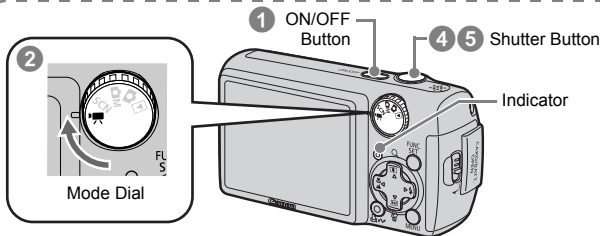

- **Set with the camera's Digital Print Order Format (DPOF) function.**  
Set the [Date] option to [On] in [Print Settings] in the  (Print) menu.
- **Connect the camera to a printer and imprint the date.**  
See the *Direct Print User Guide*.
- **Insert a memory card into the printer and imprint the date.**  
See your printer user guide.
- **Use the supplied software.**  
See the *Software Starter Guide*.

## Shooting Movies ( Standard Mode )



- 1 Press the ON/OFF button.
- 2 Select a shooting mode.
  1. Set the mode dial to  (Movie).
    - Confirm that the camera is set to  (Standard).
- 3 Aim the camera at the subject.



- Do not touch the microphone while recording.
- Do not press any buttons other than the shutter,  or  button. The sound that buttons make will be recorded in the movie.

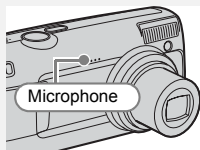



**4 Press the shutter button lightly (press halfway) to set the focus.**

- An electronic beep will sound twice and the indicator will light green when the camera focuses.
- The exposure, focus and white balance are automatically set when you press the button halfway.

**5 Without changing anything else, press the shutter button all the way (press fully) to shoot.**

- Recording starts.
- During the recording, the elapsed recording time and [● Rec] will display in the LCD monitor.



Elapsed Time

**6 Press the shutter button again (press fully) to stop recording.**

- The indicator will blink green and the data will be recorded onto the memory card.
- Recording will stop automatically when the maximum recording time elapses, or the built-in memory or memory card become full.

# Viewing Movies

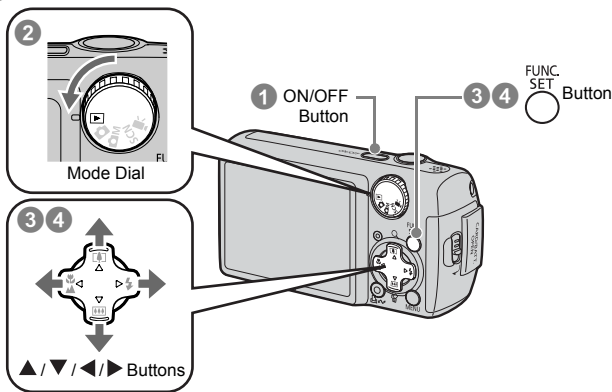

- 1 Press the ON/OFF button.
- 2 Set the mode dial to (Playback).
- 3 Use the or button to display a movie and press the FUNC./SET button.

• Images with a are movies.



- 4 Use the or button to select (Play) and press the FUNC./SET button.

- The movie will start playing.
- If you press the **FUNC./SET** button during playback, you can pause and restart the movie.
- You can adjust the playback volume with the or button.



# Downloading Images to a Computer

You are recommended to use the supplied software to download images to your computer.

## Items to Prepare

- Camera and computer
- Canon Digital Camera Solution Disk supplied with the camera
- Interface cable supplied with the camera

## System Requirements

Please install the software on a computer meeting the following minimum requirements.

### ■ Windows

<b>OS</b>	Windows Vista Windows XP Service Pack 2 Windows 2000 Service Pack 4
<b>Computer Model</b>	The above OS should be pre-installed on computers with built-in USB ports.
<b>CPU</b>	Windows Vista : Pentium 1.3 GHz or higher Windows XP/Windows 2000 : Pentium 500 MHz or higher
<b>RAM</b>	Windows Vista : 512 MB or more Windows XP/Windows 2000 : 256 MB or more
<b>Interface</b>	USB
<b>Free Hard Disk Space</b>	<ul style="list-style-type: none"> <li>• Canon Utilities               <ul style="list-style-type: none"> <li>- ZoomBrowser EX : 200 MB or more</li> <li>- PhotoStitch : 40 MB or more</li> </ul> </li> <li>• Canon Camera TWAIN Driver : 25 MB or more</li> </ul>
<b>Display</b>	1,024 x 768 pixels/High Color (16 bit) or better

### ■ Macintosh

<b>OS</b>	Mac OS X (v10.3–v10.4)
<b>Computer Model</b>	The above OS should be pre-installed on computers with built-in USB ports.
<b>CPU</b>	PowerPC G3/G4/G5 or Intel Processor
<b>RAM</b>	256 MB or more
<b>Interface</b>	USB
<b>Free Hard Disk Space</b>	<ul style="list-style-type: none"> <li>• Canon Utilities               <ul style="list-style-type: none"> <li>- ImageBrowser : 300 MB or more</li> <li>- PhotoStitch : 50 MB or more</li> </ul> </li> </ul>
<b>Display</b>	1,024 x 768 pixels/32,000 Colors or better

## Preparing to Download Images

**Windows 2000 users must install the software before connecting the camera to the computer.**

### 1 Installing the software.

#### ■ Windows

1. Place the Canon Digital Camera Solution Disk in the computer's CD-ROM drive.

2. Click [Easy Installation].

Follow the onscreen messages to proceed with the installation.



3. Click [Restart] or [Finish] once the installation is complete.

When the installation is complete, [Restart] or [Finish] will display. Click the button that appears.



4. Remove the CD-ROM from the drive when your normal desktop screen appears.

#### ■ Macintosh

Double-click the  icon in the CD-ROM window. When the installer panel appears, click [Install]. Follow the onscreen instructions to proceed.



## 2 Connecting the camera to a computer.

### 1. Connect the supplied interface cable to the computer's USB port and to the camera's DIGITAL terminal.

- Open the Camera's terminal cover and insert the interface cable all the way into the connector.

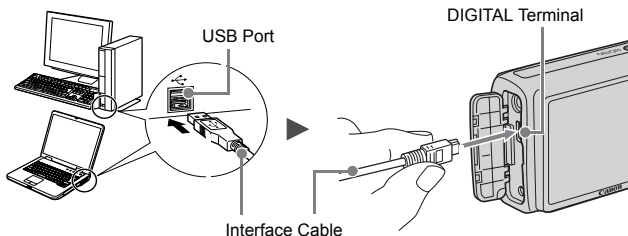

## 3 Preparing to download images to the computer.

1. Set the camera's mode dial to  (Playback) and press the ON/OFF button.

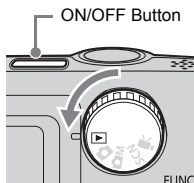

If the Digital Signature Not Found window appears, click [Yes]. The USB driver will automatically finish installing onto the computer when you attach the camera and open a connection.

#### 4 Displaying the Camera Window.

##### ■ Windows

Select [Canon CameraWindow] and click [OK].



If this event dialog does not appear, click the [Start] menu and select [All Programs] or [Programs], followed by [Canon Utilities], [CameraWindow], [CameraWindow] and [CameraWindow].

CameraWindow will display.



##### ■ Macintosh

CameraWindow will appear when you establish a connection between the camera and computer. If it fails to appear, click the [CameraWindow] icon on the Dock (the bar which appears at the bottom of the desktop).

Preparations for downloading images are now finished. Please proceed to the Downloading Images Using the Camera (Direct Transfer) section (p. 29) (except Windows 2000).



- Please refer to the *Software Starter Guide* regarding how to download images using the computer.
- If you are using Windows 2000, please download images using computer commands.

## Downloading Images Using the Camera (Direct Transfer)

Use this method to download images using camera operations (except Windows 2000).

**Install the software before downloading images via the Direct Transfer method for the first time (p. 26).**

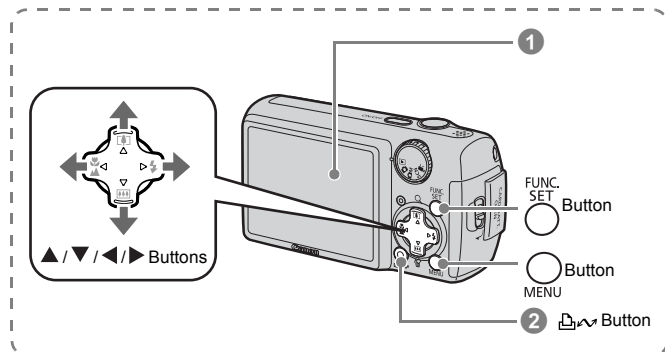

**1 Confirm that the Direct Transfer menu is displayed on the camera's LCD monitor.**

- The  button will light blue.
- Press the **MENU** button if the Direct Transfer menu fails to appear.

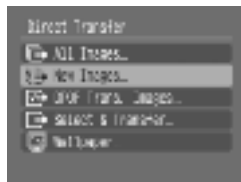





Direct Transfer Menu





**2 Press the  button.**

- Images not previously downloaded will download to the computer.

You can also use the following options in the Direct Transfer menu to set the method for downloading images.



	<b>All Images</b>	Transfers and saves all images to the computer.
	<b>New Images</b>	Transfers and saves to the computer only the images that have not been previously transferred.
	<b>DPOF Trans. Images</b>	Transfers and saves to the computer only the images with DPOF Transfer Order settings.
	<b>Select &amp; Transfer</b>	Transfers and saves single images to the computer as you view and select them.
	<b>Wallpaper</b>	Transfers and saves single images to the computer as you view and select them. The transferred images display as the background on the computer desktop.

### ■ All Images/New Images/DPOF Trans. Images

1. Confirm that the Direct Transfer menu is displayed on the camera's LCD monitor.
2. Use the ▲ or ▼ button to select , , or  and press the  button.
  - The images will download. The  button will blink blue while downloading is in progress.
  - The display will return to the Direct Transfer menu when the download is complete.
  - To cancel the download, press the **FUNC./SET** button.



### ■ Select & Transfer/Wallpaper

1. Confirm that the Direct Transfer menu is displayed on the camera's LCD monitor.
2. Use the ▲ or ▼ button to select  or  and press the  (or **FUNC./SET**) button.



**3. Use the ◀ or ▶ button to select images to download and press the  button.**

- The images will download. The  button will blink blue while downloading is in progress.

**4. Press the MENU button after downloading finishes.**

- You will return to the Direct Transfer menu.



Only JPEG images can be downloaded as wallpaper for a computer.



The option selected with the  button is retained even when the camera's power is turned off. The previous setting will be in effect the next time the Direct Transfer menu is displayed. The image selection screen will appear directly when the [Select & Transfer] or the [Wallpaper] option was last selected.

Click  at the bottom right of the window to close the CameraWindow and the downloaded images will display on the computer.

■ **Windows**



ZoomBrowser EX

■ **Macintosh**



ImageBrowser

By default, images are saved on the computer in folders according to the shooting date.

# System Map

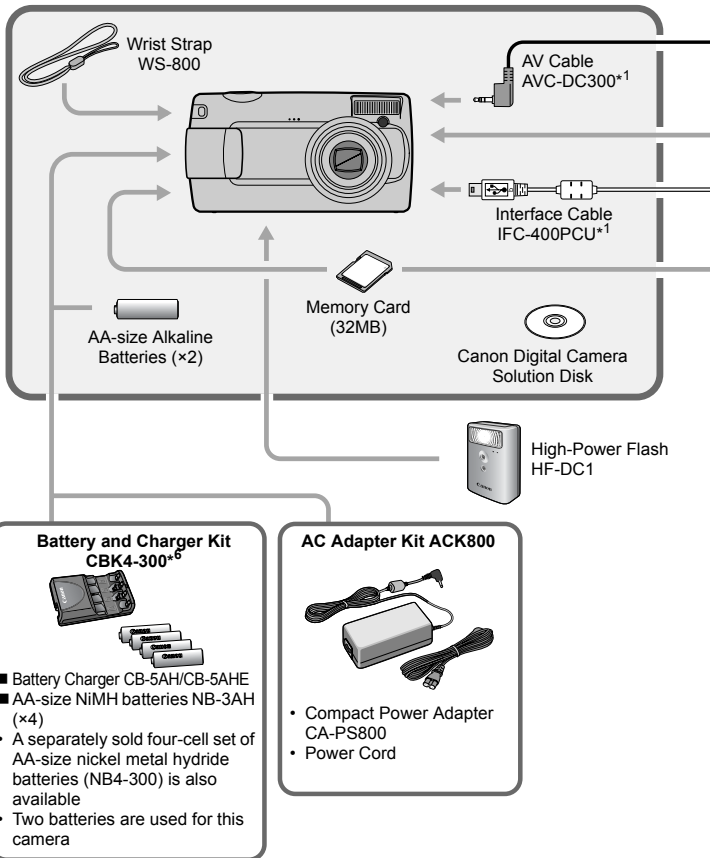

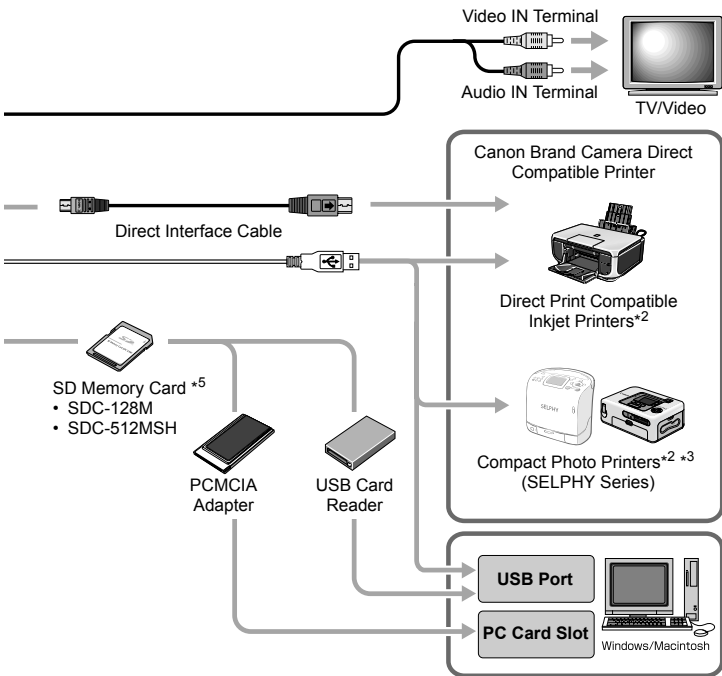

\*1 Also available for purchase separately.

\*2 See the user guide supplied with the printer for more information on the printer.

\*3 This camera can also be connected to the CP-10/CP-100/CP-200/CP-300.

\*4 See the user guide supplied with the inkjet printer for more information on the printer and interface cables.

\*5 Not sold in some regions.

\*6 The Battery and Charger Kit CBK4-200 can also be used.

## Optional Accessories

The following camera accessories are sold separately.

Some accessories are not sold in some regions, or may no longer be available.

### ■ Flash

#### • High-Power Flash HF-DC1

This attachable supplementary flash can be used to capture photographic subjects that are too distant for the built-in flash to illuminate.

### ■ Power Supplies

#### • AC Adapter Kit ACK800

This kit lets you power the camera from any standard household power outlet. Recommended to power a camera for an extended period of time or when connecting to a computer (cannot be used to charge the camera).

#### • Battery and Charger Kit CBK4-300

This dedicated battery charger kit includes both a charger unit and four rechargeable AA-size NiMH (nickel metal hydride) batteries. Convenient when taking or playing back large numbers of images. You can also purchase NiMH Battery NB4-300, a set of four rechargeable AA-size NiMH batteries separately.

### ■ Other Accessories

#### • SD Memory Card

SD memory cards are used to store images recorded by the camera. Canon brand memory cards are available in 128 MB and 512 MB capacities.

#### • Interface Cable IFC-400PCU

Use this cable to connect the camera to a computer, Compact Photo Printer (SELPHY series), or to a inkjet printer (refer to your inkjet printer user guide).

#### • AV Cable AVC-DC300

Use this cable to connect the camera to a TV set.

## Direct Print Compatible Printers

Canon offers the following separately sold printers for use with the camera. You can produce photo quality prints quickly and easily by connecting them to the camera with a single cable and operating the camera's controls.

- **Compact Photo Printers (SELPHY series)**
- **Inkjet Printers**

For more information, visit your nearest Canon retailer.

**Use of genuine Canon accessories is recommended.**

This product is designed to achieve excellent performance when used with genuine Canon accessories. Canon shall not be liable for any damage to this product and/or accidents such as fire, etc., caused by the malfunction of non-genuine Canon accessories (e.g., a leakage and/or explosion of a battery pack). Please note that this warranty does not apply to repairs arising out of the malfunction of non-genuine Canon accessories, although you may request such repairs on a chargeable basis.



# Learning More

# Components Guide

## ■ Front View

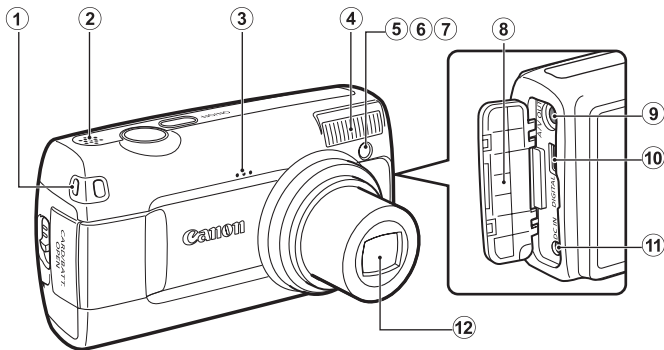

- ① Wrist Strap Mount
- ② Speaker
- ③ Microphone
- ④ Flash (p. 59)
- ⑤ AF-assist Beam (p. 47)
- ⑥ Red-Eye Reduction Lamp (pp. 59, 70)
- ⑦ Self-Timer Lamp (p. 62)
- ⑧ Terminal Cover
- ⑨ A/V OUT (Audio/Video output) Terminal (p. 129)
- ⑩ DIGITAL Terminal (p. 27)
- ⑪ DC IN (Power input) Terminal (p. 156)
- ⑫ Lens



## ■ Back View

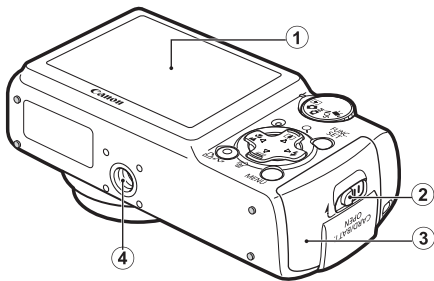

- ① LCD Monitor (pp. 44, 51)
- ② Memory Card Slot / Battery Cover Lock (p. 9)
- ③ Memory Card Slot / Battery Cover (p. 9)
- ④ Tripod Socket



The LCD monitor may be covered with a thin plastic film for protection against scratches during shipment. If so, remove the film before using the camera.

## ■ Controls

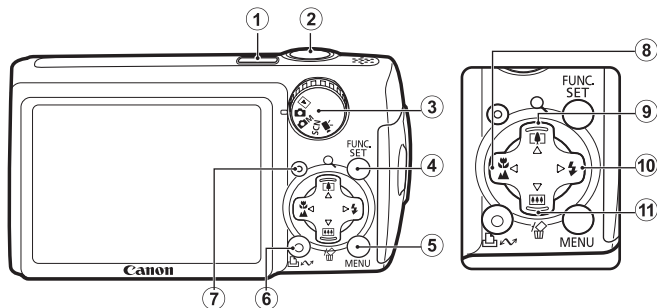

- ① ON/OFF Button (pp. 12, 14)
- ② Shutter Button (p. 14)
- ③ Mode Dial (pp. 13, 14)
- ④ **FUNC./SET** Button (p. 42)
- ⑤ **MENU** Button (p. 43)
- ⑥ (Print/Share) Button (pp. 18, 29, 93)
- ⑦ Indicator (p. 41)
- ⑧ (Macro)/ (Infinity)/ Button (p. 60)
- ⑨ (Telephoto while shooting)/ (Magnify in Playback mode)/ Button (pp. 54, 96)
- ⑩ (Flash)/ Button (p. 59)
- ⑪ (Wide Angle while shooting)/ (Single Image Erase in Playback mode)/ Button (pp. 17, 54)

## Indicator

The camera indicator on the back of the camera will light or blink under the following conditions.

- Green:** Ready to shoot (camera beeps twice)\*/  
when connected to a computer/display turned off
- Blinking Green:** Camera starting up/image recording/reading/erasing/  
transferring (when connected to a computer)
- Orange:** Ready to shoot (flash on)
- Blinking Orange:** Ready to shoot (camera shake warning)/flash  
charging
- \* Camera beeps once if difficult to focus.







Never do the following while the indicator blinks green. These actions may corrupt image data.

- Shake or jolt the camera
- Shut off the power, or open the memory card slot/battery cover

## Basic Operations





### Menus and Settings

Settings for the shooting or playback modes or such camera settings as the print settings, date/time and sounds are set using the FUNC. menu or the , ,  or  menu.

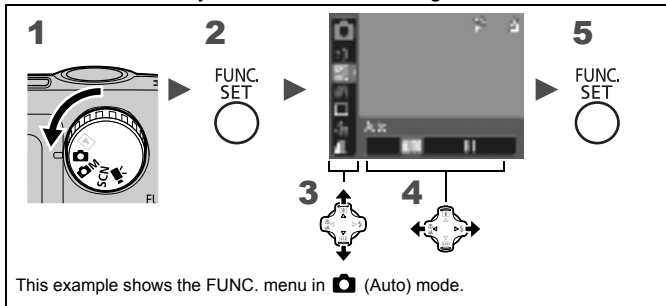
#### ■ FUNC./SET Button (FUNC. Menu)

This menu sets many of the common shooting functions.



- 1** Set the mode dial to , ,  or .
- 2** Press the **FUNC./SET** button.
- 3** Use the **▲** or **▼** button to select a menu item.
  - Some items may not be selectable in some shooting modes.
- 4** Use the **◀** or **▶** button to select an option for the menu item.
  - You can select further options with the **MENU** button for some options.
  - After selecting an option, you can press the shutter button to shoot immediately. After shooting, this menu will appear again, allowing you to adjust the settings easily.
- 5** Press the **FUNC./SET** button.

## ■ MENU Button ( [MENU], [RECALL], [PRINT] and [SETUP] Menus)

Convenient settings for shooting, playback or printing can be set with these menus.

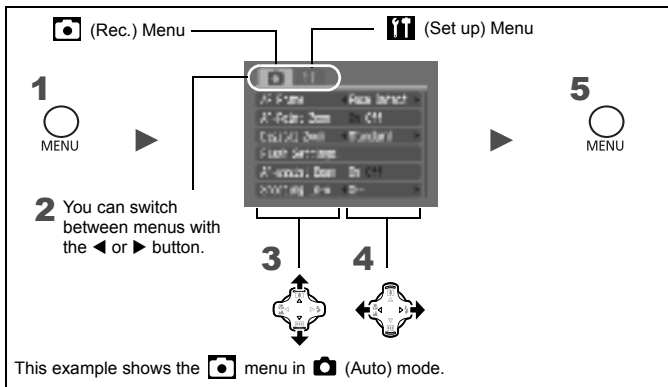

**1 Press the MENU button.**

**2 Use the ◀ or ▶ button to switch between menus.**

- The following menus are displayed.

Shooting: [CAMERA] Rec. / [SETUP] Set up

Playback: [RECALL] Play / [PRINT] Print / [SETUP] Set up

**3 Use the ▲ or ▼ button to select a menu item.**

- Some items may not be selectable in some shooting modes.

**4 Use the ◀ or ▶ button to select an option.**

- Menu items followed by an ellipsis (...) can only be set after pressing the FUNC./SET button to display the next menu. Press the FUNC./SET button again to confirm the setting, then press the MENU button to return to the menu screen.

**5 Press the MENU button.**

# Information Displayed on the LCD Monitor and Menus

Available Shooting Modes >> p. 176

## Shooting Mode

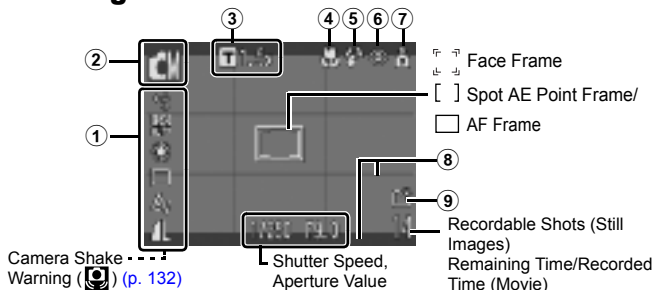

	Content	Configuration Method
①	Exposure compensation, ISO speed, recording pixels, etc.	<b>FUNC./SET</b> button (FUNC. menu)
②	Shooting mode	Mode dial, <b>FUNC./SET</b> button (FUNC. menu)
③	Digital Tele-Converter (📷 1.5x/1.9x)/ Digital Zoom Factor/Safety Zoom (📷)	<b>MENU</b> button (Rec. menu)
④	Macro (📷)/Infinity (📷)	📷 / 📷 button
⑤	Flash (📷 ⚡ 📷)	⚡ button
⑥	Red-Eye Correction (📷)	<b>MENU</b> button (Rec. menu [Flash Settings])
⑦	Auto Rotate (📷 📷 📷)	<b>MENU</b> button (Set up menu)
⑧	Disp. Overlay	<b>MENU</b> button (Rec. menu)
⑨	Create Folder (📷)	<b>MENU</b> button (Set up menu)

### About the Battery Charge Indicator

When the battery charge is low, 📷 will blink in red in the LCD monitor. Change the battery as soon as possible if you intend to use the camera for an extended period of time.

## Playback Mode

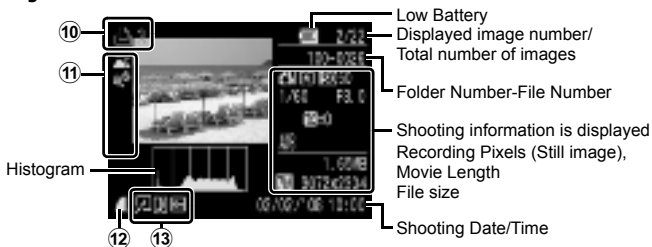

	Content	Configuration Method
⑩	Print List	button, <b>MENU</b> button (Print menu)
⑪	Auto Category (	<b>MENU</b> button (Rec. menu)
	My Category (	
⑫	Recording Pixels, Compression (Still Image)/Movie (  )	<b>FUNC./SET</b> button (FUNC. menu)
⑬	Red-Eye Correction/Resize (	<b>MENU</b> button (Play menu)
	Image with sound memo attached (	
	Protection Status (	

The following information may also be displayed with some images.

	A non-WAVE type file is attached
	JPEG image not conforming to Design rule for Camera File System Standards ( <a href="#">pp. 132, 163</a> )
	RAW image
	Unrecognized data type















- Information for images shot on other cameras may not display correctly.
- Overexposure Warning  
In the following cases, overexposed portions of the image blink.
  - When reviewing an image right after shooting in the LCD monitor (Detailed)
  - When using the Detailed Display mode of the Playback mode





## Rec. Menu

\*Default setting

Menu Item	Options	Page
AF Frame	Face Detect*/AiAF/Center	p. 76
AF-Point Zoom	On/Off*	p. 75
Digital Zoom		
(Still image)	Standard*/Off/1.5x/1.9x	p. 55
(Movie)	Standard*/Off (In Standard Movie mode only)	
Flash Settings		
Slow Synchro	On/Off*	p. 70
Red-Eye Corr.	On/Off*	
Red-Eye Lamp	On*/Off	
Light Metering	 */  / 	p. 83
AF-assist Beam	On*/Off	p. 133
Shooting Info	On/Off*	p. 51
Review	Off/2*-10 seconds/Hold	p. 15
Review Info	Off*/Detailed	p. 51
Auto Category	On*/Off	p. 92
Disp. Overlay		
(Still image)	Off*/Grid Lines/3:2 Guide/Both	p. 91
(Movie)	Off*/Grid Lines	
Set  button	 */  /  /ISO/WB/  /   /  /  / 	p. 93

## Play Menu

Menu Item	Page
Image Disp.	<a href="#">p. 97</a>
Info Disp.	<a href="#">p. 51</a>
Jump to	<a href="#">p. 99</a>
Slide Show	<a href="#">p. 104</a>
My Category	<a href="#">p. 98</a>
Red-Eye Correction	<a href="#">p. 105</a>
Resize	<a href="#">p. 110</a>
Sound Memo	<a href="#">p. 112</a>
Protect	<a href="#">p. 113</a>
Rotate	<a href="#">p. 102</a>
Erase all	<a href="#">p. 114</a>
Transfer Order	<a href="#">p. 119</a>
Resume	<a href="#">p. 16</a>
Transition	<a href="#">p. 103</a>

## Print Menu

Menu Item	Topic	Page
Print	Displays the print menu.	<a href="#">p. 115</a>
Select Image & Qty.	Configures print settings for single images as you view them.	
Select All Images	Configures print settings for all images.	
Clear All Selections	Removes all print settings from images.	
Print Settings	Configures print styles.	



## Set up Menu

\*Default setting

Menu Item	Options	Page/Topic
Mute	On/Off*	Set to [On] to silence all sounds. (Except for when the memory card slot/battery cover is opened during recording.)
Volume	Off/1/2*/3/4/5	Adjusts the volume of the start-up sound, operation sound, self-timer sound, shutter sound and playback sound. The volume cannot be adjusted if [Mute] is set to [On].
Start-up Vol.		Adjusts the volume of the start-up sound when the camera is turned on.
Operation Vol.		Adjusts the volume of the operation sound that beeps when any button other than the shutter button is pressed.
Selftimer Vol.		Adjusts the volume of the self-timer sound played 2 sec. before the shutter is released.
Shutter Volume		Adjusts the volume of the sound played when the shutter releases. The shutter sound does not play when a movie is recording.
Playback Vol.		Adjusts the playback volume of movies and sound memos.
Start-up Image	On*/Off	Sets whether or not the Start-up Image appears when the camera is turned on.
Power Saving		<a href="#">p. 121</a>
Auto Power Down	On*/Off	
Display Off	10 sec./20 sec./30 sec./1 min.*2 min./3 min.	
Date/Time		<a href="#">p. 12</a>

Menu Item	Options	Page/Topic
Format		You can also select a low level format (p. 122).
File Numbering	Continuous*/ Auto Reset	p. 123
Create Folder		p. 125
Create New Folder	Check mark (On)/ No check mark (Off)	
Auto Create	Off*/Daily/ Monday-Sunday/ Monthly (Time also can be set)	
Auto Rotate	On*/Off	p. 127
Lens Retract	1 minute* / 0 seconds	Sets the lens retraction timing when switching from Shooting mode to Playback mode.
Language		p. 13
Video System	NTSC/PAL	p. 129
Print Method	Auto*/ 	See below.
Reset All		p. 128

### Print Method

You can change the printer connection method. There is usually no need to change the settings, but select  when you print an image recorded in the  (Widescreen) mode at the full page setting for wide paper using a Canon SELPHY CP750/CP740/CP730/CP720/CP710/CP510/CP520 Compact Photo Printer. Since this setting is saved even when the power is turned off, ensure that you return the setting to [Auto] to print other image sizes. (However, it cannot be changed while the printer is connected.)

## Using the LCD Monitor



Available Shooting Modes >> p. 176

You can switch between display modes on the LCD monitor. See *Information Displayed on the LCD Monitor and Menus* for details (p. 44).

	Configuration Method	Configurable Content
During shooting (Shooting mode)	Rec. menu [Shooting Info]	On/Off
During Rec. review (while an image is reviewed right after shooting)	Rec. menu [Review Info]	Off/Detailed
During playback (Playback mode)	Play menu [Info Disp.]	Off/Standard/Detailed

### ■ During Shooting (Shooting Mode)



Off



On

### ■ During Playback (Playback Mode)/Rec. Review (Reviewing an Image Right After Shooting)



Off



Standard  
(During playback only)



Detailed

## Switching the Information Display in Shooting or Rec. Review Mode

### 1 Select [Shooting Info] or [Review Info].

1. Press the **MENU** button.
2. In the  menu, use the ▲ or ▼ button to select [Shooting Info] or [Review Info].

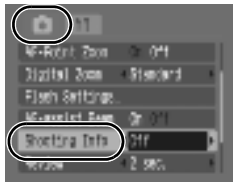

### 2 Accept the setting.

1. Use the ◀ or ▶ button to switch between options.
2. Press the **MENU** button.

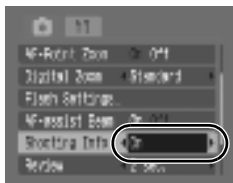

## Switching the Information Display in Playback Mode

### 1 Select [Info Disp.].

1. Press the **MENU** button.
2. In the  menu, use the ▲ or ▼ button to select [Info Disp.].

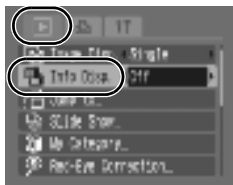

### 2 Accept the setting.

1. Use the ◀ or ▶ button to switch between options.
2. Press the **MENU** button.





- The shooting information displays for approximately 6 seconds when a setting is changed, regardless of the selected display mode.
- The LCD monitor will not switch to the detailed display in the Magnified Display mode (p. 96) or the Index Playback mode (p. 97).

### **Night Display**

When shooting in dark conditions, the camera automatically brightens the LCD monitor to suit the brightness of the subject\*, making it easier to frame the subject.

\* Although noise may appear and the movement of the subject shown on the LCD monitor may appear somewhat jagged, there is no effect on the recorded image. The brightness of the image displayed in the monitor, and the brightness of the actual image recorded will be different.



## Commonly Used Shooting Functions

### Shooting with the Optical Zoom



The zoom can be adjusted from 38 mm – 132 mm (focal length) in 35mm film equivalent terms.

#### **1 Press the or button.**

-  **Wide Angle:** Zooms out from the subject.
-  **Telephoto:** Zooms in on the subject.

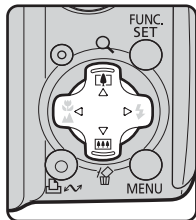



## Using the Digital Zoom/Digital Tele-Converter



Available Shooting Modes >> p. 176

You can combine digital zoom with optical zoom when shooting. The available shooting characteristics and focal lengths (35mm film equivalent) are as follows:



Selection	Focal Length	Shooting Characteristics
<b>Standard</b>	38 – 528 mm	Enables shooting at zoom factors of up to 14x with digital and optical zoom combined. In Movie mode, only the Standard mode can be selected.
<b>Off</b>	38 – 132 mm	Enables shooting without digital zoom.
<b>1.5x</b>	57 – 198 mm	Digital zoom is fixed at the selected zoom factor, and the focal length shifts to maximum telephoto. This enables a faster shutter speed and less chance of camera shake than a shot taken at the same angle of view with [Standard] or [Off].
<b>1.9x</b>	72.2 – 251 mm	



- The digital zoom cannot be used in (Date Stamp), or (Widescreen) modes.
- The [1.5x] and [1.9x] settings cannot be used in mode.



## Safety Zoom Zone

Depending on the number of recording pixels set, you can shift from optical zoom to digital zoom without pausing up to a factor where the image quality does not deteriorate (Safety Zoom).

The  icon displays at the maximum zoom factor without image deterioration and you can advance the zoom further by pressing the  button again (not available in ).

## Safety Zoom Factor

Recording pixels	Optical Zoom	Digital Zoom
<b>L</b>	3.4x →	
<b>M1</b>		4.0x →
<b>M2</b>		5.1x →
<b>M3</b>		6.5x →
<b>S</b>		14x →

-  Optical Zoom (Zone without deterioration)
-  Digital Zoom (Zone without deterioration)
-  Digital Zoom (Zoom with deterioration)

## Shooting with the Digital Zoom

### 1 Select [Digital Zoom].

1. Press the **MENU** button.
2. In the  menu, use the **▲** or **▼** button to select [Digital Zoom].

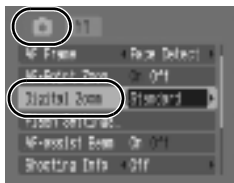

### 2 Accept the setting.

1. Use the **◀** or **▶** button to select [Standard].
2. Press the **MENU** button.

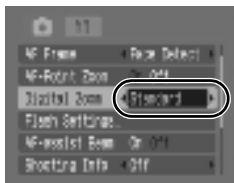

### 3 Press the button and shoot.

- The combined digital and optical zoom factor will display in the LCD monitor.
- The image may appear coarse depending upon the selected recording pixels (the zoom factor appears in blue).
- Press the  button to zoom out.



## Shooting with the Digital Tele-Converter

The digital tele-converter feature uses digital zoom to achieve the effects of a tele-converter (a lens used in telephoto shooting).

### 1 Select [Digital Zoom].

1. Press the **MENU** button.
2. In the  menu, use the **▲** or **▼** button to select [Digital Zoom].

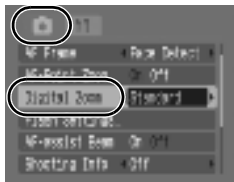

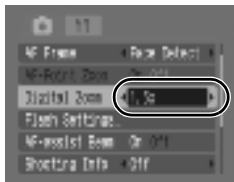

### 2 Accept the setting.

1. Use the **◀** or **▶** button to select [1.5x] or [1.9x].
2. Press the **MENU** button.



### 3 Adjust the angle of view with the or button and shoot.

-  will appear on the LCD monitor.
- The image may appear coarse depending upon the selected recording pixels (the  icon and the zoom factor appear in blue).



## ⚡ Using the Flash



Available Shooting Modes >> p. 176

### 1 Press the ⚡ button.

1. Use the ◀ or ▶ button to change the flash mode.

⚡A : [Auto]

⚡ : [On]

⊙ : [Off]

- You can configure detailed settings for the flash when you press the **MENU** button while this screen is displayed (p. 70).
  - Slow Synchro, Red-Eye Corr., Red-Eye Lamp
- The LCD monitor turns off while the flash charges.



You are recommended to shoot with the camera attached to a tripod or other device if the camera shake warning icon  appears.

## 🌸/▲ Shooting Close-ups/Infinity Shots (Macro/Infinity/Super Macro)





Available Shooting Modes >> p. 176

You can shoot close-ups or infinity shots.

Shooting Mode	Features
Macro	<p>Use this mode to shoot close-ups of flowers or small items.</p> <p><b>Image Area at Minimum Focusing Distance from End of Lens to Subject</b></p> <ul style="list-style-type: none"> <li>• Maximum wide angle setting: 53 x 40 mm (2.1 x 1.6 in.) Minimum focusing distance: 5 cm (2.0 in.)</li> <li>• Maximum telephoto setting: 76 x 57 mm (3.0 x 2.2 in.) Minimum focusing distance: 25 cm (9.8 in.)</li> </ul>
Infinity	<p>Use this mode when the distance from the end of the lens to the subject is 3 m (9.8 ft.) or greater.</p>
Super Macro	<p>You can shoot an area of 17 x 13 mm (0.67 x 0.51 in.) at a focusing distance as close as 1 cm (0.39 in.) from the end of the lens to the subject (minimum focusing distance) at maximum wide angle. With the digital zoom set at its maximum zoom factor (approx. 4.0x), you can shoot an area of 4.2 x 3.2 mm (0.17 x 0.13 in.).</p>

### Shooting in Macro/Infinity Mode

#### 1 Press the 🌸/▲ button.

1. Use the ◀ or ▶ button to select  or .



#### To Cancel the Macro/Infinity Mode







Press the 🌸/▲ button and use the ◀ or ▶ button to select  (Normal).



Using the flash in Macro mode may cause image edges to darken.

## Shooting in Super Macro Mode

### 1 Select .

1. Set the mode dial to .
2. Press the **FUNC./SET** button.
3. Use the  or  button to select  and choose  with the  or  button.
4. Press the **FUNC./SET** button.

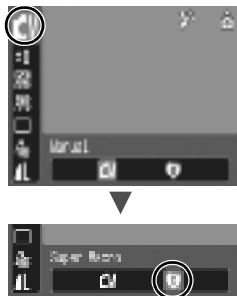

In Super Macro mode, the zoom level is fixed at maximum wide angle.

## Using the Self-Timer



Available Shooting Modes >> p. 176

You can set the time delay and the numbers of shots you wish to take in advance.

	<p><b>10 sec. Self-Timer: shoots 10 seconds after you press the shutter button.</b></p> <ul style="list-style-type: none"> <li>• 2 seconds before the shutter releases, the self-timer lamp and sound speed up.</li> </ul>
	<p><b>2 sec. Self-Timer: shoots 2 seconds after you press the shutter button.</b></p> <ul style="list-style-type: none"> <li>• When you press the shutter button, the self-timer sound will beep rapidly, the self-timer lamp will blink and the shutter will release 2 seconds later.</li> </ul>
	<p><b>Custom Timer: you can change the delay time (0–10, 15, 20, 30 sec.) and number of shots (1–10).</b></p> <ul style="list-style-type: none"> <li>• When [Delay] is set to 2 or more seconds, the self-timer sound beeps quickly 2 seconds before the shutter releases. When [Shots] is set to more than 2, the self-timer sound only beeps before the first shot.</li> <li>• This function cannot be used in Movie mode.</li> </ul>

### 1 Configure the self-timer mode.

1. Press the **FUNC./SET** button.
2. Use the **▲** or **▼** button to select  and the **◀** or **▶** button to change the option.
3. Press the **FUNC./SET** button.



### 2 Shoot.

- When you press the shutter button fully, the self-timer lamp will blink.\*
- \* When [Red-Eye Lamp] in [Flash Settings] is set to [On], the self-timer lamp will light 2 seconds before the flash fires (p. 70).





## To Cancel the Self-Timer

Follow Step 1 to display .

## Changing the Delay Time and Number of Shots ()

### 1 Select .

1. Press the **FUNC./SET** button.
2. Use the **▲** or **▼** button to select  and choose  with the **◀** or **▶** button.



### 2 Accept the setting.

1. Press the **MENU** button.
2. Use the **▲** or **▼** button to select [Delay] or [Shots] and change the settings with the **◀** or **▶** button.
3. Press the **MENU** button.
4. Press the **FUNC./SET** button.

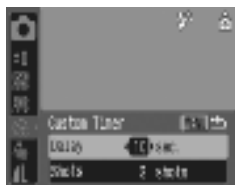

If the [Shots] option is set to 2 or more shots, the following occurs.

- The exposure and white balance are locked at the settings selected for the first shot.
- If the flash is used, the interval between shots lengthens because the flash must charge.
- The interval between shots may lengthen when the built-in memory of the camera fills.
- Shooting will automatically cease if the memory card becomes full.

## Changing the Recording Pixels (Still Images)



Available Shooting Modes >>> p. 176

### 1 Select the number of recording pixels.

1. Press the **FUNC./SET** button.
2. Use the **▲** or **▼** button to select **L** and the **◀** or **▶** button to change the option.
3. Press the **FUNC./SET** button.



### Approximate Values for Recording Pixels

Recording Pixels				Purpose*
<b>L</b> (Large)	7M	3072 x 2304 pixels	High ↑ ↓ Low	Printing to about A3-size 297 x 420 mm (11.7 x 16.5 in.)
<b>M1</b> (Medium 1)	5M	2592 x 1944 pixels		Printing to about A4-size 210 x 297 mm (8.3 x 11.7 in.) Printing to about Letter-size 216 x 279 mm (8.5 x 11 in.)
<b>M2</b> (Medium 2)	3M	2048 x 1536 pixels		Printing to about A5-size 148 x 210 mm (6 x 8.3 in.)
<b>M3</b> (Medium 3)	2M	1600 x 1200 pixels		Print postcard-size prints 148 x 100 mm (6 x 4 in.) Print L-size prints 119 x 89 mm (4.7 x 3.5 in.)
<b>S</b> (Small)	0.3M	640 x 480 pixels		Send images as e-mail attachments or shoot more images
 (Date Stamp)	2M	1600 x 1200 pixels		Printing date-stamped images (p. 20) in L-size or postcard-size (you can check the print area at a 3:2 aspect ratio as you shoot).

 <b>(Widescreen)</b>	3072 x 1728 pixels	Printing on wide size paper (you can check the composition at a 16:9 aspect ratio as you shoot. Areas that will not be recorded appear on the LCD monitor as a black border.)
---	--------------------	---

• : Approximate number of recording pixels. (M is short for megapixels.)

\* Paper sizes vary according to region.



- See *Memory Cards and Estimated Capacities* (p. 167).
- See *Image Data Sizes (Estimated)* (p. 169).

## Changing the Compression (Still Images)







Available Shooting Modes >> p. 176

### 1 Select a compression setting.

1. Press the **FUNC./SET** button.
2. Use the **▲** or **▼** button to select  and press the **MENU** button.
3. Use the **◀** or **▶** button to change the option.
4. Press the **FUNC./SET** button.



### Approximate Values for Compression Settings

Compression		Purpose
 <b>Superfine</b>	High Quality	Shoot higher quality images
 <b>Fine</b>		Shoot normal quality images
 <b>Normal</b>	Normal	Shoot more images

## Various Shooting Methods

### SCN Shooting Modes for Specific Scenes

SCN

Available Shooting Modes &gt;&gt; p. 176

You can shoot with the most appropriate settings for the scene.

#### 1 Select a shooting mode.

1. Set the mode dial to **SCN**.
2. Press the **FUNC./SET** button.
3. Use the ▲ or ▼ button to select  and the ◀ or ▶ button to select a mode.
4. Press the **FUNC./SET** button.



#### Portrait

Produces a soft effect when photographing people.



#### Night Snapshot

Allows you to take snapshots of people against twilight or night backgrounds by reducing the effects of camera shake when firmly holding the camera, even without using a tripod.



#### Kids&Pets

Allows you to capture subjects that move around, such as children and pets, without missing photo opportunities.

**Indoor**

Prevents camera shake and maintains the subject's true color when shooting under fluorescent or tungsten lighting.

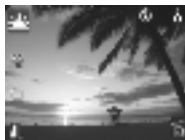
**Sunset**

Allows you to shoot sunsets in vivid colors.

**Foliage**

Shoots trees and leaves—such as new growth, autumn leaves or blossoms—in vivid colors.

**Snow**

Shoots without a blue tinge and without making people appear dark against a snowy background.

**Beach**

Shoots without making people appear dark near water or sand where reflected sunlight is strong.

**Fireworks**





Captures fireworks in the sky sharply and at optimal exposure.



### Aquarium

Selects the optimal ISO speed, white balance and color balance to capture fish and other items in an indoor aquarium.



- The shutter speed is slow in the  mode. Always use a tripod to avoid camera shake.
- In the , ,  or  mode, the ISO speed may increase and cause noise in the image depending on the scene being shot.



## Shooting in Manual Mode



Available Shooting Modes >>> [p. 176](#)

Allows you to select settings yourself, such as the exposure compensation, white balance or my colors.

### 1 Select Manual mode.

1. Set the mode dial to .
2. Press the **FUNC./SET** button.
3. Use the **◀** or **▶** button to select .
4. Press the **FUNC./SET** button.



## Continuous Shooting



Available Shooting Modes >> p. 176



In this mode, the camera shoots continuously while the shutter button is held down. If you use the recommended memory card\*, you can shoot continuously (smooth continuous shooting) at a set shooting interval until the memory card is full (p. 167).

### \*Recommended Memory Card:

Super high-speed SDC-512MSH memory card (sold separately) to which low-level formatting (p. 122) is conducted immediately before shooting.

- This reflects standard shooting criteria established by Canon. Actual results may vary according to the subject and shooting conditions.
- Even if continuous shooting suddenly stops, the memory card may not be full.

## 1 Select .

1. Press the **FUNC./SET** button.
2. Use the **▲** or **▼** button to select  and choose  with the **◀** or **▶** button.
3. Press the **FUNC./SET** button.



## 2 Shoot.

- The camera will continue to record successive images while the shutter button is held down. Recording will cease when the shutter button is released.

### To Cancel Continuous Shooting

Follow Step 1 to display .



- The interval between shots lengthens when the built-in memory of the camera fills.
- If the flash is used, the interval between shots lengthens because the flash must charge.





## 2 Accept the setting.

1. Use the ▲ or ▼ button to select a function.
2. Use the ◀ or ▶ button to select [On] or [Off].
3. Press the **MENU** button.
  - You can also display this menu by pressing the ⚡ button, followed by the **MENU** button (p. 59).

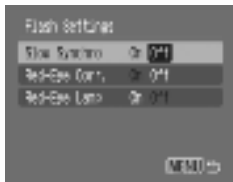

## 3 Press the MENU button.

## **Movie Shooting**



**Available Shooting Modes** >> p. 176

The following movie modes are available.

The recording time will vary according to the capacity of the memory card you use (p. 168).



### **Standard**

You can select the recording pixels and record until the memory card is full (when a super high-speed memory card is used, such as the recommended SDC-512MSH). The digital zoom can be used while shooting in this mode (p. 55).

- Maximum Size: 4 GB\*/movie





### **Compact**

Since there are few recording pixels and also the data size is small, this mode is convenient for sending movies as e-mail attachments or when the memory card capacity is low.

- Maximum Clip Length: 3 minutes

\* Even if the file size has not reached 4 GB, the recording is stopped when the recording time reaches one hour. Depending on memory card capacity and data write speed, recording may stop before the file size reaches 4 GB or the recording time reaches one hour.

## **1 Select a shooting mode.**

1. Set the mode dial to .
2. Press the **FUNC./SET** button.
3. Use the **▲** or **▼** button to select  and the **◀** or **▶** button to change the option.
4. Press the **FUNC./SET** button.



## 2 Shoot.

- Pressing the shutter button halfway automatically sets the exposure, focus and white balance settings.
- Pressing the shutter button fully starts recording video and sound simultaneously.
- During shooting, the recording time and [● Rec] appear on the LCD monitor.
- Pressing the shutter button fully again stops recording. Recording will stop automatically under the following circumstances.
  - When the maximum recording time or maximum size elapses
  - When the built-in memory or memory card becomes full



- You are recommended to use a memory card that has been formatted in your camera to shoot movies (p. 122). The memory card supplied with the camera may be used without further formatting.
- Be careful of the following while recording.
  - Do not touch the microphone (p. 38).
  - Do not press any buttons other than the shutter, [▲] or [AAA] button. The sound that buttons make will be recorded in the movie.
  - The camera will automatically adjust the exposure and white balance to suit the shooting conditions during recording. Please note, however, that the sounds made by the camera automatically adjusting the exposure may also be recorded.
- The focus and optical zoom settings remain fixed for subsequent frames at the values selected for the first frame.



- Adjust the zoom before shooting. The factor of the combined optical zoom and digital zoom display on the LCD monitor. When the factor displays in blue, the image will deteriorate.
- Only in [640] and [640] in the Standard mode, the digital zoom can be used during shooting.
- QuickTime is required to play back movies (Data type: AVI/ Compression method: Motion JPEG) on a computer (Only Windows 2000).

## Changing Recording Pixels/Frame Rates

You can change the recording pixels when the Movie mode is set to  (Standard). The frame rate can be set depending on the recording pixels.







### 1 Select the number of recording pixels.

1. Press the **FUNC./SET** button.
2. Use the **▲** or **▼** button to select  and the **◀** or **▶** button to change the option.
3. Press the **FUNC./SET** button.



## Recording Pixels and Frame Rates

Frame rates indicate the number of frames recorded or played back each second. The higher the frame rate, the smoother the appearance of motion.

 Standard	 *1	640 x 480 pixels, 20 frames/sec.
	 *2	640 x 480 pixels, 20 frames/sec. LP
		320 x 240 pixels, 30 frames/sec.
 Compact		160 x 120 pixels, 15 frames/sec.

\*1 Default setting.

\*2 To give priority to recording length over quality, select the option displaying [LP] (Long Play). For the same file size, you can record approximately twice the length.



- See *Memory Cards and Estimated Capacities* (p. 167).
- See *Image Data Sizes (Estimated)* (p. 169).

## Checking the Focus and People's Expressions



Available Shooting Modes >>> p. 176

You can zoom the display of the AF frame area to check the focus and people's expressions as you compose and shoot.

To do this you must first set the [AF Frame] in the  menu to [Face Detect] or [Center].

### 1 Select [AF-Point Zoom].

1. Press the **MENU** button.
2. In the  menu, use the **▲** or **▼** button to select [AF-Point Zoom].



### 2 Accept the setting.

1. Use the **◀** or **▶** button to select [On].
2. Press the **MENU** button.

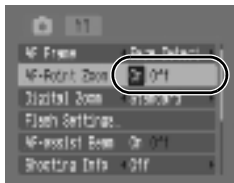

### 3 Press the shutter button halfway.

- Pressing the shutter button halfway zooms a section of the display according to the following AF Frame mode settings (p. 76).
  - **[Face Detect]**: The face detected as the main subject will appear zoomed.
  - **[Center]**: The center of the LCD monitor will appear zoomed.

### 4 If the subject is in focus, press the shutter button all the way to shoot.



The display cannot be zoomed under the following circumstances.

- When the [AF Frame] is set to [Face Detect] and a face is not detected, or when the face is extremely large in relation to the overall composition.
- When the camera cannot focus.
- When the digital zoom or Digital Tele-converter function is in use.
- When a TV is being used as the display.

## Selecting an AF Frame Mode



Available Shooting Modes >>> p. 176

The Auto Focus frame (AF frame) indicates the area of the composition on which the camera focuses.

	<b>Face Detect</b>	The camera detects a face and sets the focus, exposure* <sup>1</sup> and white balance* <sup>2</sup> . In addition, the camera meters the subject so that the face is correctly illuminated when the flash fires. If no face is detected, the camera shoots using [AiAF]. *1 Only in Evaluative Metering mode (p. 83). *2 Only in <b>AVC</b> (p. 86).
	<b>AiAF</b>	The camera automatically selects between 9 AF frames to focus on according to the shooting conditions.
	<b>Center</b>	The camera fixes the AF frame at the center. This is recommended when the target subject is at the center of the composition.

### 1 Select [AF Frame].

1. Press the **MENU** button.
2. In the  menu, use the **▲** or **▼** button to select [AF Frame].



## 2 Accept the setting.

1. Use the ◀ or ▶ button to select [Face Detect], [AiAF] or [Center].
2. Press the **MENU** button.



The AF frame appears as follows when the shutter button is pressed halfway.

- Green : In focus
- Yellow : Focusing difficulty ([Center])
- No AF frame: Focusing difficulty ([Face Detect], [AiAF])

### Face Detect Feature

- Maximum of three frames will be displayed at the positions of the faces the camera recognizes. At this point, the frame the camera judges to be the main subject appears in white while the others appear in gray. When the shutter button is pressed halfway and the focus is achieved, up to 9 green AF frames may appear.
- The camera will shoot using [AiAF] not the [Face Detect] function if a white frame fails to appear and only gray frames display, or if a face is not detected.
- The camera may mistakenly identify non-human subjects as a face.
- In certain cases, faces may not be detected.

Examples:

- If faces appear extremely small or large, dark or bright, relative to the overall composition.
- Faces turned to the side or at a diagonal, or faces with a portion hidden.

## Selecting the Face to Focus On (Face Select and Track)





Available Shooting Modes >> p. 176

Once the focus is fixed to a subject's face, the frame can be set to follow the subject within a certain range.



To use the Face Select and Track function, first configure the following settings.

- In the  menu, set [AF Frame] to [Face Detect] (p. 76).
- Register the  function to the  button (p. 93).

# 1

**Aim the camera at the subject and press the  button when the face is detected.**

- The Face Select mode will activate and a green face frame () will display around the main subject.

Face Frame





## 2 Use the ◀ or ▶ button to select a person to focus on.

- If multiple faces are detected, you can move the face frame with the ◀ or ▶ button. The face frame will not appear if no face is detected.
- You can display face frames around faces detected by the camera while pressing the **MENU** button (up to 35 frames).
  - **Green:** face of main subject
  - **White:** detected face
- You can turn the Face Select mode On/Off by pressing the ▲ or ▼ button.





Switch between Face Select modes.

## 3 Press the button.

- The face frame () of the main subject turns to white and determines the person to focus on (the selected face will now be tracked within a certain range).

## 4 Press the shutter button halfway.

- The face frame () of the main subject will change into .

## 5 Press the shutter button all the way to shoot.



The Face Select mode releases if the following operations are performed in Step 3 after the  button is pressed.

- Power is turned off and on again or shooting mode is changed
- Digital zoom or Digital Tele-converter is used
- Menu is displayed
- Mode is changed to **[W]**
- Face is no longer detected
- When the display is turned off

## Shooting Hard-to-Focus Subjects (Focus Lock)



Available Shooting Modes >> p. 176

It may be difficult to focus on the following types of subjects.

- Subjects with extremely low contrast to the surroundings
- Scenes with a mixture of near and far subjects
- Subjects with extremely bright objects at the center of the composition
- Subjects that are moving quickly
- Subjects through glass

**1 Aim the camera so that an object at the same focal distance as the main subject is centered in the AF frame.**

**2 Press the shutter button halfway to lock the focus.**

**3 Keep the shutter button pressed halfway while you recompose the image and press the shutter button all the way to shoot the image.**



- Since AF frames do not display in  mode, aim the camera so that the focus is on the target subject.
- When shooting with the focus lock, setting [AF Frame] to [Center] (p. 76) makes shooting easier since the camera focuses using the center AF frame only.
- When shooting the subjects through glass, try to shoot as close to the glass as possible to reduce the chances of light reflecting back off the glass.

## Adjusting the ISO Speed



Available Shooting Modes >> p. 176

Raise the ISO speed to use a fast shutter speed when you wish to reduce the effects of camera shake or avoid blurry subjects, or to turn the flash off when shooting in a dark area.

### 1 Adjust the ISO Speed

1. Press the **FUNC./SET** button.
2. Use the **▲** or **▼** button to select **ISO AUTO** and the **◀** or **▶** button to change the setting.
3. Press the **FUNC./SET** button.



- Selecting **ISO AUTO** (Auto) or **ISO HI** (High ISO Auto) sets the optimal ISO speed for the light condition when shooting. Since the ISO speed setting will automatically be raised in dark places, the camera will select a faster shutter speed and reduce the chances of camera shake.
  - To put priority on image quality, select **ISO AUTO** (Auto).
  - Selecting **ISO HI** (High ISO Auto) sets the optimal ISO speed also when the camera detects motion. With some shooting scenes, it may set the ISO speed higher\* than the Auto mode, reducing the chances of camera shake.
- \* Noise may increase in the captured image compared to **ISO AUTO**.



- The camera automatically applies noise reduction processing when you shoot at a high ISO speed.
- If the camera is set at **ISO AUTO** or **ISO HI**, the ISO speed automatically set by the camera will be displayed when pressing shutter button halfway or in playback information.

## Adjusting the Exposure Compensation



Available Shooting Modes >> p. 176

Adjust the exposure compensation to a positive value to avoid making the subject too dark when it is backlit or shot against a bright background. Adjust the exposure compensation to a negative value to avoid making the subject too bright in night shots or when shot against a dark background.

### 1 Adjust the exposure.

1. Press the **FUNC./SET** button.
2. Use the **▲** or **▼** button to select **±0** and the **◀** or **▶** button to adjust the setting.
3. Press the **FUNC./SET** button.



### To Cancel the Exposure Compensation

Restore the compensation value to [0].

# Switching between Metering Modes



Available Shooting Modes >> p. 176

	<b>Evaluative</b>	<p>Appropriate for standard shooting conditions, including backlit scenes. The camera divides images into several zones for metering. It evaluates complex lighting conditions, such as the position of the subject, the brightness, the direct light, and the backlighting, and adjusts the settings to the correct exposure for the main subject.</p>
	<b>Center Weighted Avg.</b>	<p>Averages the light metered from the entire frame, but gives greater weight to the subject matter at the center.</p>
	<b>Spot</b>	<p>Use when there is a large difference in brightness between the subject and the surroundings. Sets the exposure to suit the subject at the center of the composition.</p>

## 1 Select [Light Metering].

1. Press the **MENU** button.
2. In the menu, use the ▲ or ▼ button to select [Light Metering].

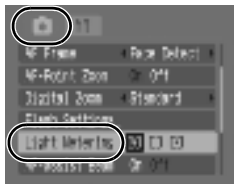

## 2 Accept the setting.

1. Use the ◀ or ▶ button to select a metering mode.
2. Press the **MENU** button.

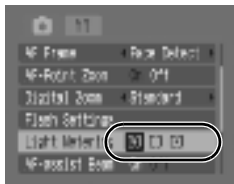

In Long Shutter mode, the metering mode is automatically fixed to [Evaluative].

## Setting a Slow Shutter Speed (Long Shutter Mode)



Available Shooting Modes >> p. 176

You can set the shutter speed to a slow setting to make dark subjects appear brighter.

### 1 Select the Long Shutter mode.

1. Press the **FUNC./SET** button.
2. Use the **▲** or **▼** button to select **+0**.
3. Press the **MENU** button.



### 2 Change the shutter speed.

1. Use the **◀** or **▶** button to adjust the setting.
2. Press the **FUNC./SET** button.
  - The higher the value, the brighter the recorded image becomes.
  - If you press the **MENU** button at this point, you will return to the Exposure Compensation setting screen.





- The brightness of the image appearing on the LCD monitor and the recorded image may differ.
- The nature of CCD image sensors is such that noise in the recorded image increases at long shutter speeds. This camera, however, applies special processing to images shot at shutter speeds of 1.3 seconds or slower to eliminate the noise, thereby producing high-quality images. A certain amount of processing time, however, may be required before the next image can be shot.









- Use the LCD monitor to confirm that the image was recorded at the desired brightness
- Please note that camera shake becomes a factor at low shutter speeds. Shoot with the camera attached to a tripod.
- Use of the flash may result in an over-exposed image. If this occurs, shoot with the flash set to .
- The following are not available:
  - Exposure Compensation
  - Metering
  - ISO speed: Auto, High ISO Auto
  - Flash: Auto
  - Slow Synchro





## Adjusting the Tone (White Balance)

Available Shooting Modes  p. 176



Normally, the  (Auto) white balance setting selects an optimal white balance. When the  setting cannot produce natural looking colors, change the white balance using a setting appropriate for the light source.

	<b>Auto</b>	Settings are automatically set by the camera.
	<b>Day Light</b>	For recording outdoors on a bright day.
	<b>Cloudy</b>	For recording under overcast, shady or twilight skies.
	<b>Tungsten</b>	For recording under tungsten and bulb-type 3-wavelength fluorescent lighting.
	<b>Fluorescent</b>	For recording under warm-white, cool-white or warm-white (3-wavelength) fluorescent lighting.
	<b>Fluorescent H</b>	For recording under daylight fluorescent, or daylight fluorescent-type 3-wavelength fluorescent lighting.
	<b>Custom</b>	For recording with the optimal white balance data memorized in the camera from a white-colored object, such as white paper or cloth.

### 1 Select a white balance setting.

1. Press the **FUNC./SET** button.
2. Use the  or  button to select  and the  or  button to change the option.
3. Press the **FUNC./SET** button.



The white balance setting cannot be adjusted when  or  is selected for My Colors.



## Using the Custom White Balance

Take a custom white balance reading for the following situations that are difficult for the **AWB** (Auto) setting to detect correctly.

- Shooting subjects of monotone color (such as sky, sea or forest)
- Shooting with a particular source of light (such as a mercury-vapor lamp)
- Shooting close-ups (Macro)

### 1 Select .

1. Press the **FUNC./SET** button.
2. Use the **▲** or **▼** button to select **AWB** and choose  with the **◀** or **▶** button.

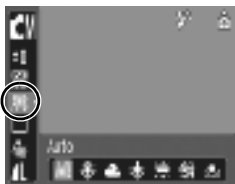





### 2 Aim the camera at a piece of white paper or cloth and press the **MENU** button.

- Ensure that the center frame is completely filled with the white image. Please note that the center frame will not appear when the digital zoom is in use or **T** displays.



### 3 Press the **FUNC./SET** button.









- You are recommended to set the Shooting mode to  and the exposure compensation setting to  $[\pm 0]$  before setting a custom white balance.  
The correct white balance may not be obtained when the exposure setting is incorrect (image appears completely black or white).
- Shoot with the same settings as when reading the white balance data. If the settings differ, the optimal white balance may not be set.  
In particular, the following should not be changed.
  - ISO Speed
  - Flash  
Setting the flash to  or  is recommended. If the flash fires when reading the white balance data with the flash set to , make sure that you also use the flash when you shoot.
- Recorded white balance data will be retained even when the camera's power is turned off.

## Shooting in a My Colors Mode



Available Shooting Modes >> p. 176

You can change the look of an image when it is shot.

	<b>My Colors Off</b>	Records normally with this setting.
	<b>Vivid</b>	Emphasizes the contrast and color saturation to record bold colors.
	<b>Neutral</b>	Tones down the contrast and color saturation to record neutral hues.
	<b>Sepia</b>	Records in sepia tones.
	<b>B/W</b>	Records in black and white.
	<b>Custom Color</b>	Use this option to adjust contrast, sharpness and saturation before shooting.

## Configuring My Colors Settings (///

### 1 Select a My Colors setting.

1. Press the **FUNC./SET** button.
2. Use the **▲** or **▼** button to select  and the **◀** or **▶** button to change the option.
3. Press the **FUNC./SET** button.
  - Return to the shooting screen and shoot.



## Setting the Camera to a Custom Color Mode (C)

### 1 Select C.

1. Press the **FUNC./SET** button.
2. Use the ▲ or ▼ button to select **OFF** and choose **C** with the ◀ or ▶ button.



### 2 Adjust the setting.

1. Press the **MENU** button.
2. Use the ▲ or ▼ button to select [Contrast], [Sharpness] or [Saturation].
3. Use the ◀ or ▶ button to adjust the setting.
  - The adjustment results show in the LCD monitor.
  - Press the **MENU** button to return to the My Colors mode selection screen.
4. Press the **FUNC./SET** button.
  - Return to the shooting screen and shoot.

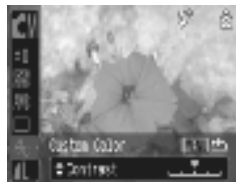

## Setting the Display Overlays



Available Shooting Modes >> p. 176

You can display vertical and horizontal grid lines, a 3:2 print area guide, or both on the LCD monitor while shooting to help check the position of your subject.

<b>Grid Lines</b>	Displays grid lines to divide the screen into 9 parts. Helps confirm the vertical and horizontal positioning of the subject.
<b>3:2 Guide</b>	Helps to confirm the print area for L-size or postcard size in 3:2 aspect ratio*. Areas outside the printable area are grayed out. * Images are still recorded at the standard aspect ratio of 4:3.
<b>Both</b>	Displays both the grid lines and the 3:2 guide simultaneously.

### 1 Select [Disp. Overlay].

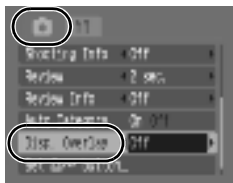

1. Press the **MENU** button.
2. In the  menu, use the **▲** or **▼** button to select [Disp. Overlay].



### 2 Accept the setting.

1. Use the **◀** or **▶** button to select [Off], [Grid Lines], [3:2 Guide] or [Both].
2. Press the **MENU** button.



- In  and  modes, only [Grid Lines] can be set.
- The grid lines and 3:2 guide will not be recorded in the image.

## Categorizing Images Automatically (Auto Category)



Available Shooting Modes >> p. 176

If you set Auto Category to [On], images are automatically sorted into preset categories as they are recorded.

	<b>People</b>	For images shot in  ,  or  mode, or images with faces detected when [AF Frame] is set to [Face Detect].
	<b>Scenery</b>	For images shot in  or  mode.
	<b>Events</b>	For images shot in  ,  ,  ,  or  mode.

### 1 Select [Auto Category].

1. Press the **MENU** button.
2. In the menu, use the **▲** or **▼** button to select [Auto Category].

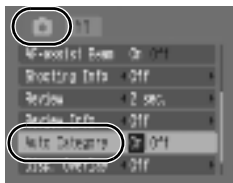

### 2 Accept the setting.

1. Use the **◀** or **▶** button to select [On] or [Off].
2. Press the **MENU** button.

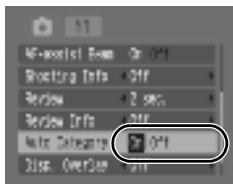















Movies are not automatically categorized, but they can be categorized using the My Category function (p. 98).

## **Registering Settings to the Print/Share Button**





**Available Shooting Modes** >> p. 176

You can register a function that you often use when shooting with the  button. The following functions can be registered.



	Menu Item	Purpose	Page
	<b>Not Assigned</b>	No function is registered to the  button	—
	<b>Face Select</b>	Selects the person to focus on	p. 78
	<b>+/- (Exp.)</b>	For correcting the exposure	p. 82
	<b>ISO Speed</b>	For changing the ISO speed	p. 81
	<b>White Balance</b>	For changing the white balance	p. 86
	<b>Custom White Balance</b>	For recording white balance data	p. 87
	<b>Red-Eye Corr.</b>	For switching between red-eye correction settings	p. 70
	<b>Digital Tele-converter</b>	For switching between Digital Tele-converter settings	p. 58
	<b>DISP. Overlay</b>	For switching between shooting guides	p. 91
	<b>Vert. Shutter</b>	For using the  button as a shutter button when the camera is held vertically	p. 95
	<b>Info Display</b>	For switching between shooting information display modes	p. 51
	<b>Display Off</b>	For switching off the LCD monitor	p. 121

## 1 Select [Set button].

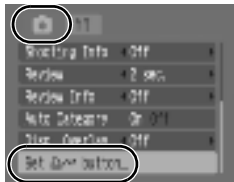
1. Press the **MENU** button.
2. In the  menu, use the **▲** or **▼** button to select [Set  button].
3. Press the **FUNC./SET** button.



## 2 Accept the setting.

1. Use the **▲**, **▼**, **◀** or **▶** button to select the function you wish to register.
2. Press the **FUNC./SET** button.
  - If  displays to the icon's lower right, you can register the function, but you cannot use it with some shooting modes or settings even if you press the  button.

















### To Cancel the Shortcut Button

Select  in Step 2.







## Using the Button

### 1 Press the button.

- : The Face Select mode activates.
-    : The settings advance each time the  button is pressed.
-  **ISO WB**: The corresponding setup screen is displayed.
- : The white balance data is read each time the  button is pressed. Since the frame does not appear at this point, ensure that the white paper or cloth is positioned so it appears at the center of the LCD monitor and then press the  button. After using this function once, the white balance setting changes to the custom white balance setting.
- : The LCD monitor turns off when you press the  button. It powers back on when you press a button other than the ON/OFF button or when you change the camera's vertical/horizontal orientation.
- : The  button can be used in place of the shutter button when the camera is held vertically.

### Vertical Shutter Release

With the camera held vertically, you can release the shutter by pressing the  button in place of the shutter button.

- The  button will behave as follows.
  - Lights: Vertical release available
  - Blinks: Movie recording in progress
- When the camera focuses, it will beep twice and record the image immediately (The  button does not need to be pressed halfway).
- When the vertical shutter release function is registered to the  button, images cannot be added to the print list even when the  button is pressed (p. 19).
- You can also shoot using the shutter button.

## Playback/Erasing

### 🔍 Viewing Magnified Images



#### 1 Press the 🔍 button.

- **SET** 🔍 will display and allow you to magnify the view up to a factor of 10 times. Pressing the **🔍** button zooms the display out.
- Pressing the **◀** or **▶** button allows you to display the previous or next image at the magnified level.



Approximate Location  
of the Displayed Area

#### 2 Press the **FUNC./SET** button and change the position of the displayed area with the **▲**, **▼**, **◀** or **▶** button.

- **SET** 🔍 will display and the camera switches to the Image Advance mode.
- Press the **FUNC./SET** button again to cancel the Image Advance mode.

#### To Cancel the Magnified Display

Press the **MENU** button.



Movie frames and index playback images cannot be magnified.

## Viewing Images in Sets of Nine (Index Playback)



### 1 Select [Image Disp.].

1. Press the **MENU** button.
2. In the menu, use the **▲** or **▼** button to select .



### 2 Accept the setting.

1. Use the **◀** or **▶** button to select [Index].
2. Press the **MENU** button.



- Up to nine images can be viewed at once in index playback.
- Use the **▲**, **▼**, **◀** or **▶** button to change the image selection.



Movie

Selected Image













You can also switch between single image playback and index playback by holding down the **FUNC./SET** button.





## Jumping to Images



When you have many images recorded onto a memory card, it is handy to use the search keys below to jump over images to find the object of your search.

	<b>Jump Shot Date</b>	Jumps to the first image of each shooting date.
	<b>People</b>	Jumps to images from the [People] category.
	<b>Scenery</b>	Jumps to images from the [Scenery] category.
	<b>Events</b>	Jumps to images from the [Events] category.
	<b>Category 1-3</b>	Jumps to the images from each category.
	<b>To Do</b>	Jumps to images from the [To Do] category.
	<b>Jump to Folder</b>	Jumps to the first image of each folder.
	<b>Jump to Movie</b>	Jumps to a movie.
	<b>Jump 10 Images</b>	Jumps to the image 10 images ahead.
	<b>Jump 100 Images</b>	Jumps to the image 100 images ahead.

### 1 Select [Jump to].

1. Press the **MENU** button.
2. In the  menu, use the ▲ or ▼ button to select .
3. Press the **FUNC./SET** button.
  - The camera will switch to Jump Search mode.

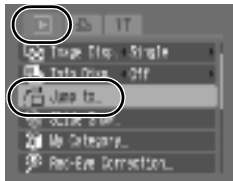

## 2 Use the ▲ or ▼ button to select a search key and press the ◀ or ▶ button.

- Some search keys only display when there is a corresponding image in the folder.

### Date Jump Example



Location of image currently being displayed

Number of images matching search key

### To Cancel the Jump Search Mode

Press the **MENU** button.



In Single Playback mode, you can also display the [Jump to] menu by holding down the **MENU** button.

## Viewing Movies



Movies cannot be played in the Index Playback mode.

### 1 Display the movie file.

1. Use the ◀ or ▶ button to select a movie.
2. Press the **FUNC./SET** button.
  - The movie control panel will display.
  - Images with a **SET**  icon are movies.



## 2 Play the movie.

1. Use the ◀ or ▶ button to select .
2. Press the **FUNC./SET** button.
  - The movie will pause if you press the **FUNC./SET** button during playback. It will resume when you press the button again.
  - When playback ends, the movie stops at the last frame displayed.
  - If playback was halted partway through in the prior viewing session, playback will resume from the last frame displayed.

Movie Control Panel











Playback Progress Bar

Time movie was shot

Volume Level  
(Adjust it with the ▲ or ▼ button)

## Operating the Movie Control Panel

	Exit	Ends playback and returns to single image playback
	Print	An icon will display when a printer is connected. See the <i>Direct Print User Guide</i> for details.
	Play	Play
	Slow Motion	You can use the ◀ button to slow down or the ▶ button to speed up playback.
	First Frame	Displays the first frame
	Previous Frame	Rewinds if the <b>FUNC./SET</b> button is held down.
	Next Frame	Fast Forwards if the <b>FUNC./SET</b> button is held down.
	Last Frame	Displays the last frame



- Use the television's controls to adjust the volume when playing a movie on a TV set (p. 129).
- The sound cannot be played in slow motion playback.

## Rotating Images in the Display



Images can be rotated clockwise 90° or 270° in the display.

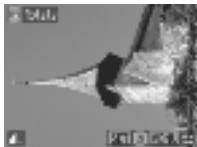

Original



90°



270°

### 1 Select [Rotate].

1. Press the **MENU** button.
2. In the menu, use the **▲** or **▼** button to select .
3. Press the **FUNC./SET** button.

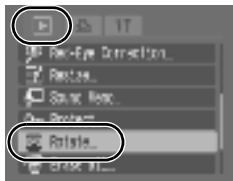

### 2 Rotate the image.

1. Use the **◀** or **▶** button to select an image to rotate.
2. Press the **FUNC./SET** button.
  - Cycle through the 90°/270°/original orientations with each press of the **FUNC./SET** button.
  - This also can be set in the Index Playback mode.



When images are downloaded to a computer, the orientation of images rotated by the camera will depend upon the software used to download the images.



## Playback with Transition Effects



You can select the transition effect displayed when switching between images.

	No transition effect.
	The displayed image darkens and the next image gradually brightens until it is displayed.
	Press the ◀ button to have the previous image display from the left and the ▶ button to have the next image display from the right.

### 1 Select [Transition].

1. Press the **MENU** button.
2. In the menu, use the ▲ or ▼ button to select .

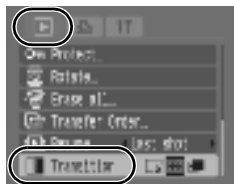

### 2 Accept the setting.

1. Use the ◀ or ▶ button to select , , or .
2. Press the **MENU** button.

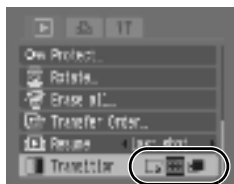

## Automated Playback (Slide Show)



Use this feature to automatically play back all of the images in the memory card. The LCD monitor displays each image for approximately 3 seconds.

### 1 Select [Slide Show].

1. Press the **MENU** button.
2. In the menu, use the **▲** or **▼** button to select .
3. Press the **FUNC./SET** button.

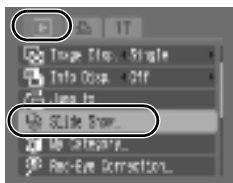

### 2 Select an effect.

1. Use the **◀** or **▶** button to select or .



### 3 Start the slide show.

1. Press the **FUNC./SET** button.
  - The following functions are available during slide shows.
    - Pausing/resuming the slide show: Press the **FUNC./SET** button
    - Fast forwarding/rewinding: Press the **◀** or **▶** button (holding down the button will increase the speed of the fast forward)
    - Stop the slide show: Press the **MENU** button



In Single Playback mode, you can start a slide show from the currently displayed image by holding the **FUNC./SET** button while you press the button. Please note that if you do this while the last image shot is displayed, the slide show will start from the first image using the same date.

## Red-Eye Correction Function



You can correct red eyes in recorded images.



Since red eyes may not be automatically detected on some images or may not be corrected as expected, you are recommended to use the [New File] function to save important images under a different name.

Examples:

- Faces near the screen edges or faces that appear extremely small, large, dark or bright in relation to the overall image.
- Faces turned to the side or at a diagonal, or faces with a portion hidden.

### 1 Select [Red-Eye Correction].

1. Press the **MENU** button.
2. In the  menu, use the **▲** or **▼** button to select .
3. Press the **FUNC./SET** button.

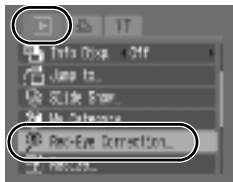

### 2 Select an image.

1. Use the **◀** or **▶** button to select the image you wish to correct red eyes.
2. Press the **FUNC./SET** button.
  - A frame will automatically display where red-eye is detected.
  - If red-eye is not automatically detected, select [Add Frame] with **◀** or **▶** button and press **FUNC./SET** button (p. 108).
  - To cancel the correction frame, select [Remove Frame] and press the **FUNC./SET** button (p. 109).



### 3 Correct the image.

1. Use the ◀ or ▶ button to select [Start].
2. Press the **FUNC./SET** button.



### 4 Save the image.

1. Use the ◀ or ▶ button to select [New File] or [Overwrite].
2. Press the **FUNC./SET** button.

- [New File]: Saved as new file with a new name. The uncorrected image is stored. The new image is stored as the last file.
- [Overwrite]: Saved with the same file name as the uncorrected image. The uncorrected image is erased.
- When [New File] is selected, proceed to Step 5.
- To continue correcting red-eyes in other images, return to Step 2.



### 5 Display the saved image.

1. Press the **MENU** button.
2. Use the ◀ or ▶ button to select [Yes].
3. Press the **FUNC./SET** button.

- Selecting [No] returns to the  menu.



- Red-eye correction cannot be performed on movies.
- Overwriting cannot be performed on protected images.



- When there is not enough space left on the memory card, red-eye correction cannot be performed.
- Although you can apply red eye correction any number of times to an image, the image quality will gradually deteriorate with each application.
- Since the correction frame will not appear automatically on images that have already been corrected once with the (Red-Eye Correction) function, use the [Add Frame] option to correct them.
- The correction frame will not appear automatically on images that have already been corrected with the red-eye correction function. Use the [Add Frame] option if you want to perform further corrections.

## Add Correction Frame

### 1 Select [Add Frame].

1. Use the ◀ or ▶ button to select [Add Frame].
2. Press the **FUNC./SET** button.
  - A green frame will display.





### 2 Adjust the position of the frame.

1. Use the ▲, ▼, ◀ or ▶ button to move the frame.
  - Press the **FUNC./SET** button to switch to the Frame Size Change mode and you can change the size of the frame with the ▲ or ▼ buttons. Press the **FUNC./SET** button again to restore the Frame Shift mode, allowing you to adjust the position of the correction frame.



### 3 Add a correction frame.

1. Press the  button.
  - The correction frame will be added and the frame color will change to white.
  - Press the  button to add additional frames.
  - Up to 35 frames may be added.
  - Press the **MENU** button to finish adding correction frames.



To correctly perform red-eye correction, please note the following (refer to the image in Step 2 above):

- Adjust the correction frame size so that it only surrounds the red-eye portion to be corrected.
- When there are several subjects with red-eye, be sure to add one correction frame per subject.

## Removing Correction Frames

### 1 Select [Remove Frame].

1. Use the ◀ or ▶ button to select [Remove Frame].
2. Press the **FUNC./SET** button.



### 2 Adjust the position of the frame.

1. Use the ◀ or ▶ button to select a frame to remove.
  - The selected frame will appear in green.



### 3 Delete the frame.

1. Press the **FUNC./SET** button.
  - The selected frame will disappear.
  - To continue deleting frames, return to Step 2.
  - When you finish deleting frames, press the **MENU** button.



## Resizing Images



You can save images at lower recording pixels than the original image.

<b>M3</b>	1600 x 1200 pixels
<b>S</b>	640 x 480 pixels
<b>XS</b>	320 x 240 pixels

### 1 Select [Resize].

1. Press the **MENU** button.
2. In the  menu, use the **▲** or **▼** button to select .
3. Press the **FUNC./SET** button.

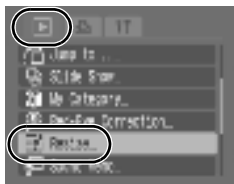

### 2 Select an image.

1. Use the **◀** or **▶** button to select an image to resize.
2. Press the **FUNC./SET** button.
  - The **FUNC./SET** button is not selectable for images that cannot be resized.



### 3 Select the recording pixels.

1. Use the **◀** or **▶** button to select **M3**, **S** or **XS**.
2. Press the **FUNC./SET** button.
  - Some recording pixel settings cannot be selected depending on the available space of the memory card.





## 4 Save the image.

1. Use the ◀ or ▶ button to select [OK].
2. Press the **FUNC./SET** button.
  - The resized image will be saved with a new file name. The original image will remain.



## 5 Display the saved image.

1. Press the **MENU** button.
2. Use the ◀ or ▶ button to select [Yes].
3. Press the **FUNC./SET** button.
  - Selecting [No] returns to the  menu.

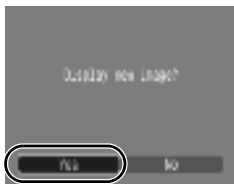



Movies and images shot in Widescreen mode cannot be resized.

## Attaching Sound Memos to Images

In Playback mode, you can attach sound memos (up to 1 min.) to an image. The sound data is saved in the WAVE format.

### 1 Select [Sound Memo].

1. Press the **MENU** button.
2. In the  menu, use the **▲** or **▼** button to select .
3. Press the **FUNC./SET** button.

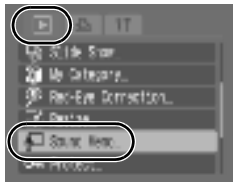

### 2 Select an image.

1. Use the **◀** or **▶** button to select an image to which you wish to attach a sound memo.
2. Press the **FUNC./SET** button.
  - The sound memo panel will display.



### 3 Record the memo.

1. Use the **◀** or **▶** button to select .
2. Press the **FUNC./SET** button.
  - The elapsed time and the remaining time display.
  - Pressing the **FUNC./SET** button pauses the recording. Pressing it again resumes recording.
  - Up to 1 minute of recordings can be added to any one image.







Sound Memo Panel

Elapsed Time/  
Remaining Time

Volume  
(Adjust it with the **▲** or **▼**  
button)

## Sound Memo Panel

Use the ◀ or ▶ button to select an option and press the **FUNC./SET** button.

	<b>Exit</b>	Ends the operation.
	<b>Record</b>	Starts recording.
	<b>Pause</b>	Stops recording or playback.
	<b>Play</b>	Plays back.
	<b>Erase</b>	Erases. (Select [Erase] in the confirmation screen and press the <b>FUNC./SET</b> button.)





- You cannot attach sound memos to movies.
- Sound memos for protected images cannot be erased.

## Protecting Images



You can protect important images and movies from accidental erasure.

### 1 Select [Protect].

1. Press the **MENU** button.
2. In the  menu, use the ▲ or ▼ button to select .
3. Press the **FUNC./SET** button.

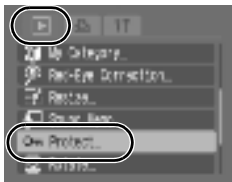

### 2 Protect the image.

1. Use the ◀ or ▶ button to select an image to protect.
2. Press the **FUNC./SET** button.
  - The protection icon appears on the lower left of the image.
  - Pressing the **FUNC./SET** button again cancels the setting.
  - You can also protect images in the Index Playback mode.



Protection Icon

## Erasing All Images



Erasing all the images on a memory card.



- Note that erased images cannot be recovered. Exercise adequate caution before erasing an image.
- Protected images cannot be erased with this function.

### 1 Select [Erase all].

1. Press the **MENU** button.
2. In the  menu, use the **▲** or **▼** button to select .
3. Press the **FUNC./SET** button.

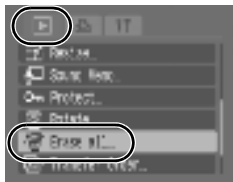

### 2 Erase the images.

1. Use the **◀** or **▶** button to select [OK].
  2. Press the **FUNC./SET** button.
- To exit instead of erasing, select [Cancel].



Please format the memory card when you want to erase not only image data but also all the data contained on the memory card ([p. 122](#)).

## Print Settings/Transfer Settings

### Setting the DPOF Print Settings

You can select images on a memory card for printing and specify the number of print copies in advance using the camera. The settings used on the camera comply with the Digital Print Order Format (DPOF) standards. This is extremely convenient for printing on a direct print compatible printer, or for sending the images to a photo developing service that supports DPOF.



- The specified print settings are also applied to the print list (p. 19).
- The output of some printers or photo developing services may not reflect the specified print settings.
- Print settings cannot be set for movies.
- The  icon may display for a memory card with print settings set by a different DPOF-compliant camera. These settings will be overwritten by those set by your camera.

### Setting the Print Style

After setting the print style, select the images for printing.

\* Default setting

Print Type	<input checked="" type="checkbox"/> <b>Standard*</b>	Prints one image per page.
	<input type="checkbox"/> <b>Index</b>	Prints the selected images together at a reduced size in an index format.
	<input checked="" type="checkbox"/> <input type="checkbox"/> <b>Both</b>	Prints the images in both the standard and index formats.
<input checked="" type="checkbox"/> <b>Date (On/Off*)</b>	Adds the date to the print.	
<input checked="" type="checkbox"/> <b>File No. (On/Off*)</b>	Adds the file number to the print.	
<b>Clear DPOF data (On*/Off)</b>		Clears all print settings after the images print.

## 1 Select [Print Settings].

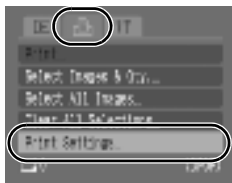

1. Press the **MENU** button.
2. Use the ◀ or ▶ button to select the  menu.
3. Use the ▲ or ▼ button to select [Print Settings].
4. Press the **FUNC./SET** button.

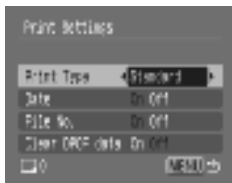

## 2 Accept the setting.

1. Use the ▲ or ▼ button to select [Print Type], [Date], [File No.] or [Clear DPOF data].
2. Use the ◀ or ▶ button to select an option.
3. Press the **MENU** button.



- The Date and File No. settings change according to the Print Type as follows.
  - [Index]  
[Date] and [File No.] cannot be set to [On] at the same time.
  - [Standard] or [Both]  
[Date] and [File No.] can be set to [On] at the same time, however, the printable information may vary between printers.
- Images with the date embedded using  (Date Stamp) (p. 20) are always printed with the date, regardless of the [Date] setting. As a result, some printers may print the date twice on these images if [Date] is also set to [On].
- The date is printed with the date style selected in the [Date/Time] settings on the  menu (p. 12).

## Single Images

You can set the number of print copies when the [Print Type] setting (p. 115) is set to [Standard] or [Both].

### 1 Select [Select Images & Qty.].

1. Press the **MENU** button.
2. Use the ◀ or ▶ button to select the  menu.
3. Use the ▲ or ▼ button to select [Select Images & Qty.].
4. Press the **FUNC./SET** button.

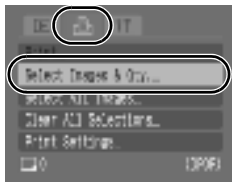

### 2 Select the images.

- Selection methods differ for the Print Type settings (p. 115).

#### Standard ( )/Both ( )

1. Use the ◀ or ▶ button to select the images.
2. Press the **FUNC./SET** button.
3. Use the ▲ or ▼ button to select the number of print copies (up to 99).
4. Press the **MENU** button.

Number of Print Copies



#### Index ( )

1. Use the ◀ or ▶ button to select the images.
  2. Select and deselect with the **FUNC./SET** button.
  3. Press the **MENU** button.
- You can also select images in the Index Playback mode.

Index Print Selection

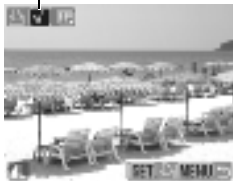

## All the Images on a Memory Card

One copy of every image will be set to print.

### 1 Select [Select All Images].

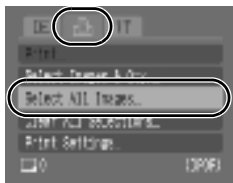

1. Press the **MENU** button.
2. Use the ◀ or ▶ button to select the  menu.
3. Use the ▲ or ▼ button to select [Select All Images].
4. Press the **FUNC./SET** button.

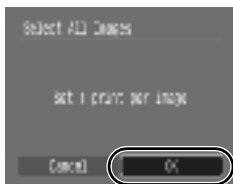

### 2 Select [OK].

1. Use the ◀ or ▶ button to select [OK].
2. Press the **FUNC./SET** button.



- Images are printed in order according to the file number.
- A maximum of 998 images can be selected.
- When the camera is connected to a printer, the  button will light blue. At this time, press the  button, confirm that [Print] is selected, and when the **FUNC./SET** button is pressed, printing will begin.
- You can cancel the print settings for all images by selecting [Clear All Selections] in Step 1.



## Setting the DPOF Transfer Settings

You can use the camera to specify settings for images before downloading to a computer. Refer to the *Software Starter Guide* for instructions on how to transfer images to your computer.

The settings used on the camera comply with the DPOF standards.



The  icon may display for a memory card with print transfer settings set by a different DPOF-compliant camera. These settings will be overwritten by those set by your camera.

### Single Images

#### 1 Select [Transfer Order].

1. Press the **MENU** button.
2. In  menu, use the **▲** or **▼** button to select .
3. Press the **FUNC./SET** button.

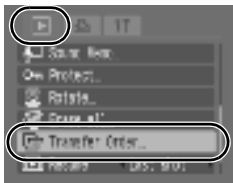

#### 2 Select [Order].

1. Use the **◀** or **▶** button to select [Order].
2. Press the **FUNC./SET** button.
  - Selecting [Reset] cancels all transfer order settings.

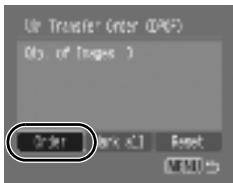

#### 3 Select the images.

1. Use the **◀** or **▶** button to select images to transfer.
2. Press the **FUNC./SET** button.
  - Pressing the **FUNC./SET** button again deselects the setting.
  - You can also select images in the Index Playback mode.
  - Press the **MENU** button several times to complete the setting. The screen will return to the  menu.



## All the Images on a Memory Card

### 1 Select [Transfer Order].

1. Press the **MENU** button.
2. In the  menu, use the **▲** or **▼** button to select .
3. Press the **FUNC./SET** button.

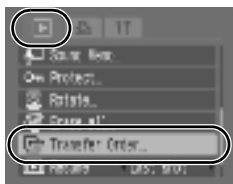

### 2 Select [Mark all].

1. Use the **◀** or **▶** button to select [Mark all]
2. Press the **FUNC./SET** button.
  - Selecting [Reset] cancels all transfer order settings.



### 3 Select [OK].

1. Use the **◀** or **▶** button to select [OK].
2. Press the **FUNC./SET** button.

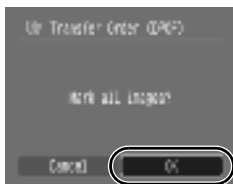

- Images are transferred in order according to the file number.
- A maximum of 998 images can be selected.

## Configuring the Camera

### Setting the Power Saving Function



This camera is equipped with a power saving function, which can automatically turn off the power or LCD monitor.

<b>Auto Power Down</b>	<p>When [Auto Power Down] is set to [On], the camera power turns off in the following situations. Pressing the ON/OFF button restores camera power.</p> <ul style="list-style-type: none"> <li>• <b>Shooting mode:</b> Approximately 3 minutes after the last control is accessed on the camera.</li> <li>• <b>Playback mode, connected to printer:</b> Approximately 5 minutes after the last control is accessed on the camera.</li> </ul>
<b>Display Off</b>	<p>In Shooting mode, the LCD monitor automatically turns off after the specified period of time if no control is accessed on the camera regardless of the [Auto Power Down] setting. Press any button other than the ON/OFF button or change the camera orientation to turn the LCD monitor back on.</p>

#### 1 Select [Power Saving].

1. Press the **MENU** button.
2. Use the ◀ or ▶ button to select the **ff** menu.
3. Use the ▲ or ▼ button to select [Power Saving].
4. Press the **FUNC./SET** button.

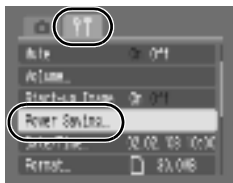

#### 2 Accept the setting.

1. Use the ▲ or ▼ button to select [Auto Power Down] or [Display Off].
2. Use the ◀ or ▶ button to change the settings.
3. Press the **MENU** button.

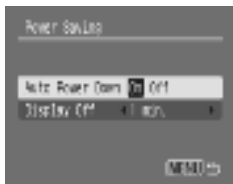



The power saving function will not activate during a slide show or while the camera is connected to a computer.

## Formatting Memory Cards



You should always format a new memory card or one from which you wish to erase all images and other data.



Please note that formatting (initializing) a memory card erases all data, including protected images and other file types.

### 1 Select [Format].

1. Press the **MENU** button.
2. Use the ◀ or ▶ button to select the  menu.
3. Use the ▲ or ▼ button to select [Format].
4. Press the **FUNC./SET** button.

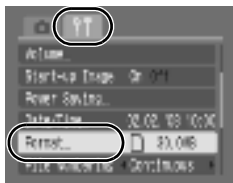

### 2 Accept the setting.

1. Use the ◀ or ▶ button to select [OK].
2. Press the **FUNC./SET** button.
  - To perform a low level format, use the ▲ button to select [Low Level Format] and the ◀ or ▶ button to add a check mark.
  - You can stop formatting a memory card when [Low Level Format] is selected by pressing the **FUNC./SET** button. You can still use a memory card without problem when formatting is halted, but its data will be erased.

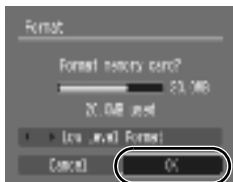

#### Low Level Format

We recommend you select [Low Level Format] when you think that the recording/reading speed of a memory card has dropped. A low level format may require 2 to 3 minutes with some memory cards.

## Resetting the File Number



The images you shoot are automatically assigned file numbers. You can select how the file number is assigned.

<p><b>Continuous</b></p>	<p>A number one higher than the last one recorded is assigned to the next image. This is convenient for managing all your images together on a computer because you avoid file name duplication when changing folders or memory cards.*</p> <p>* When a blank memory card is used. If a memory card with recorded data is used, the 7-digit number for the last recorded folder and image is compared with the last one on the memory card, and the larger of the two is utilized as the basis for new images.</p>
<p><b>Auto Reset</b></p>	<p>The image and folder number are reset to the starting value (100-0001).* This is convenient for managing images on a folder-by-folder basis.</p> <p>* When a blank memory card is used. If a memory card with recorded data is used, the number following the 7-digit number for the last recorded folder and image on the memory card is utilized as the basis for new images.</p>

### 1 Select [File Numbering].

1. Press the **MENU** button.
2. Use the ◀ or ▶ button to select the **[[** menu.
3. Use the ▲ or ▼ button to select [File Numbering].

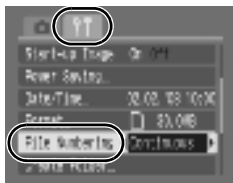

### 2 Accept the setting.

1. Use the ◀ or ▶ button to select [Continuous] or [Auto Reset].
2. Press the **MENU** button.

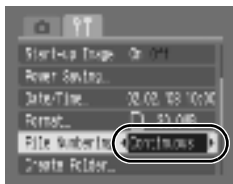

## File and Folder Numbers

Recorded images are assigned consecutive file numbers starting with 0001 and ranging up to 9999, while folders are assigned numbers starting with 100 and ranging up to 999. Up to 2000 images can be saved into a single folder.

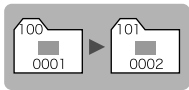
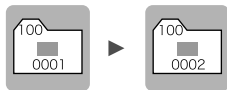
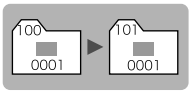
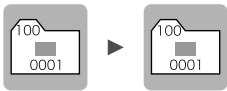
	New Folder Created	Memory Card Exchanged for Another
Continuous	<p>Memory Card 1</p> 	<p>Memory Card 1    Memory Card 2</p> 
Auto Reset	<p>Memory Card 1</p> 	<p>Memory Card 1    Memory Card 2</p> 

- Images may be saved to a new folder when there is insufficient free space even if the total number of images in a folder is less than 2000 because the following types of images are always saved together into the same folder.
  - Images from continuous shooting
  - Self-timer images (custom)
- Images cannot be played back when the folder numbers are duplicated or image numbers are duplicated within folders.
- Please refer to the *Software Starter Guide* for information regarding folder structures or image types.

## Creating an Image Destination (Folder)



You can create a new folder at any time and the recorded images will be automatically saved to that folder.

<b>Create New Folder</b>	Creates a new folder the next time you shoot images. To create an additional folder, insert the check mark again.
<b>Auto Create</b>	You can also specify a date and time if you wish to create a new folder using a shooting time after the specified date and time.

### Creating a Folder the Next Time You Shoot.

#### 1 Select [Create Folder].

1. Press the **MENU** button.
2. Use the ◀ or ▶ button to select the **ff** menu.
3. Use the ▲ or ▼ button to select [Create Folder].
4. Press the **FUNC./SET** button.

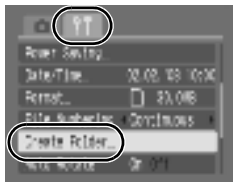

#### 2 Accept the setting.

1. Use the ◀ or ▶ button to check mark [Create New Folder].
2. Press the **MENU** button.
  - will be displayed on the LCD monitor when shooting. The icon will cease to display after the new folder is created.

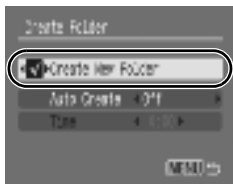

## Setting the Day or Time for Automatic Folder Creation.

### 1 Select [Create Folder].

1. Press the **MENU** button.
2. Use the ◀ or ▶ button to select  menu.
3. Use the ▲ or ▼ button to select [Create Folder].
4. Press the **FUNC./SET** button.

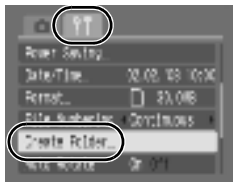

### 2 Accept the setting.

1. Use the ▲ or ▼ button to select [Auto Create] and the ◀ or ▶ button to select a creation date.
2. Use the ▲ or ▼ button to select [Time] and the ◀ or ▶ button to select a time.
3. Press the **MENU** button.
  -  displays when the specified time arrives. The icon will cease to display after the new folder is created.

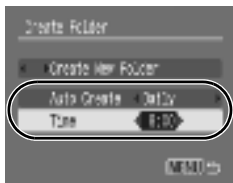

Up to 2000 images can be saved into one folder. A new folder will automatically be created when you record more than 2000 even if you are not creating new folders.



## Setting the Auto Rotate Function





Your camera is equipped with an Intelligent Orientation sensor that detects the orientation of an image shot with the camera held vertically and automatically rotates it to the correct orientation when viewing it in the LCD monitor.

### 1 Select [Auto Rotate].

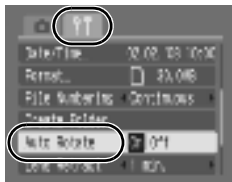
1. Press the **MENU** button.
2. Use the ◀ or ▶ button to select the  menu.
3. Use the ▲ or ▼ button to select [Auto Rotate].



### 2 Accept the setting.

1. Use the ◀ or ▶ button to select [On] or [Off].
2. Press the **MENU** button.
  - When the Auto Rotate function is set to [On] and [Shooting Info] is set to [On],  (normal),  (right end is down), or  (left end is down) will display on the LCD monitor while shooting.



- This function may not operate correctly when the camera is pointed straight up or down. Check that the arrow  is pointing in the right direction and if it is not, then set the Auto Rotate function to [Off].
- Even if the Auto Rotate function is set to [On], the orientation of images downloaded to a computer will depend upon the software used to download the images.



When the camera is held vertically to shoot, the Intelligent Orientation sensor judges the upper end to be “up” and the lower end to be “down”. It then regulates the optimal white balance, exposure and focus for vertical photography. This function operates regardless of the on/off status of the Auto Rotate function.

## Resetting Settings to Their Default Values



### 1 Select [Reset All].

1. Press the **MENU** button.
2. Use the ◀ or ▶ button to select the **ff** menu.
3. Use the ▲ or ▼ button to select [Reset All].
4. Press the **FUNC./SET** button.

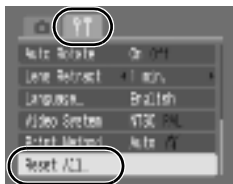

### 2 Accept the setting.

1. Use the ◀ or ▶ button to select [OK].
2. Press the **FUNC./SET** button.



- Settings cannot be reset when the camera is connected to a computer or to a printer.
- The following cannot be reset.
  - Shooting mode
  - The [Date/Time], [Language] and [Video System] options in the **ff** menu (pp. 49, 50)
  - White balance data recorded with the custom white balance function

## Connecting to a TV

### Shooting/Playback Using a TV



You can use the supplied AV cable to shoot or playback images using a TV.

#### 1 Turn off the camera and the TV.

#### 2 Connect the AV cable to the camera's A/V OUT terminal.

- Open the terminal cover and plug the AV cable in all the way.

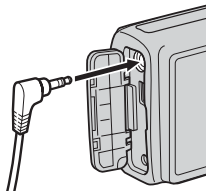

#### 3 Plug the other ends of the AV cable to the VIDEO IN and AUDIO IN jacks on the TV.

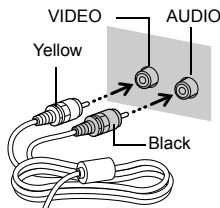

#### 4 Turn on the TV and switch it to video mode.

#### 5 Turn on the camera.



- The video output signal can be switched (NTSC or PAL) to accommodate different regional standards (p. 50). The default setting varies between regions.
  - NTSC: Japan, U.S.A., Canada, Taiwan and others
  - PAL: Europe, Asia (excluding Taiwan), Oceania and others
- If the video system is set incorrectly, the camera output may not display properly.

## Troubleshooting

- Camera (p. 130)
- When the power is turned on (p. 131)
- LCD monitor (p. 131)
- Shooting (p. 133)
- Shooting movies (p. 137)
- Playback (p. 138)
- TV monitor output (p. 138)
- Battery (p. 139)
- Printing with a direct print compatible printer (p. 139)

## Camera

### Camera will not operate.

Power is not turned on.	● Press the ON/OFF button (p. 14).
Memory card slot/battery cover is open.	● Confirm that the cover is securely closed (p. 9).
Batteries are loaded in the wrong direction.	● Reload the batteries in the correct direction (p. 10).
Batteries are not the right type.	● Use only unused AA-size alkaline batteries or Canon AA-size NiMH batteries (p. 150).
Battery charge is low and the camera will not operate. ("Change the batteries" message displays).	<ul style="list-style-type: none"> <li>● Replace the camera batteries with 2 unused or fully charged batteries (p. 150).</li> <li>● Use the AC Adapter Kit ACK800 (sold separately) (p. 156).</li> </ul>
Poor contact between camera and battery terminals.	<ul style="list-style-type: none"> <li>● Wipe the battery terminals with a clean dry cloth.</li> <li>● Reload the batteries several times.</li> </ul>

**Sounds come from the camera interior.**

The camera's horizontal/vertical orientation was changed.

- The camera's orientation mechanism is operating. There is no malfunction.

**When the power is turned on****"Card locked!" message appears.**

The SD memory card's or SDHC memory card's write protect tab is set to "Write protect".

- When recording to, erasing from or formatting the memory card, slide the write protect tab upward (p. 152).

**The Date/Time menu appears.**

The lithium date/time coin battery charge is depleted.

- Replace the lithium date/time coin battery (p. 159).

**LCD monitor****Nothing displays.**

[Power Saving] is set to [Display Off].

- Press any button other than the ON/OFF button or change the camera orientation to turn the LCD monitor back on (p. 127).

**The display darkens.**

The image in the LCD monitor will darken in strong sunlight or bright light.

- This is a normal occurrence in devices containing CCDs and does not constitute a malfunction. This image will not be recorded when shooting still photos, but it will be recorded when shooting movies.

**Display flickers.**

Display flickers when shot under fluorescent lighting.

- This is not a camera malfunction (flickering recorded in movies, but not in still images).

**A bar of light (purplish red) appears on the LCD monitor.**

Sometimes appears when shooting a bright subject, such as the sun or other light source.

- This is a normal occurrence in devices containing CCDs and does not constitute a malfunction. This bar of light will not be recorded when shooting still photos, but it will be recorded when shooting movies.

** appears.**

A slow shutter speed has likely been selected because of insufficient lighting.

- Raise the ISO speed (p. 81).
- Select a setting other than  (flash off) (p. 59).
- Set the self-timer and attach the camera to a tripod or other device (p. 62).

** appears.**

This displays when using a memory card that has print settings or transfer settings set by other DPOF-compliant cameras.

- These settings will be overwritten by those set by your camera (pp. 115, 119).





**Noise displays./Subject's movements are irregular.**

Camera automatically lightened the image displayed on the LCD monitor to make it easier to see when shooting in a dark area (p. 53).

- There is no effect on the recorded image.

## Shooting

### Camera will not record.

Mode dial is set to  (playback).	<ul style="list-style-type: none"> <li>● Set the mode dial to  (Auto),  (Manual), <b>SCN</b> (Special Scene) or  (Movie) (pp. 14, 22, 66, 68).</li> </ul>
Flash is charging.	<ul style="list-style-type: none"> <li>● When the flash is charged, the indicator will light orange. Shooting is now possible (p. 41).</li> </ul>
Memory card is full.	<ul style="list-style-type: none"> <li>● Insert a new memory card (p. 9).</li> <li>● If required, download the images to a computer and erase them from the memory card to make space.</li> </ul>
Memory card is not formatted correctly.	<ul style="list-style-type: none"> <li>● Format the memory card (p. 122).</li> <li>● If reformatting does not work, the memory card logic circuits may be damaged. Consult the nearest Canon Customer Support Help Desk.</li> </ul>
SD memory card or SDHC memory card is write protected.	<ul style="list-style-type: none"> <li>● Slide the write protect tab upward (p. 152).</li> </ul>

### Image is blurred or out of focus.

The camera moves when the shutter button is pressed.	<ul style="list-style-type: none"> <li>● Confirm the procedures in “ appears” (p. 132).</li> </ul>
AF-assist Beam is set to [Off].	<ul style="list-style-type: none"> <li>● In dark places where it is difficult for the camera to focus, the AF-assist Beam will emit to assist focusing. As the AF-assist Beam will not function when turned off, set it [On] to activate it (p. 47). Take care not to obstruct the AF-assist Beam with your hand when used.</li> </ul>

Subject is out of focal range.	<ul style="list-style-type: none"> <li>● Shoot with the subject at the correct focusing distance (p. 162).</li> <li>● The camera may be set to an unintended function (such as Macro mode). Cancel the setting.</li> </ul>
--------------------------------	--

The subject is hard to focus on.	<ul style="list-style-type: none"> <li>● Use the focus lock to shoot (p. 80).</li> </ul>
----------------------------------	--

### **Subject in recorded image is too dark.**

Insufficient light for shooting.	<ul style="list-style-type: none"> <li>● Set the flash to  (Flash on) (p. 59).</li> </ul>
The subject is underexposed because the surroundings are too bright.	<ul style="list-style-type: none"> <li>● Set the exposure compensation to a positive (+) setting (p. 82).</li> <li>● Use the spot metering functions (p. 83).</li> </ul>



Subject is too far away for flash to reach.	<ul style="list-style-type: none"> <li>● Shoot with the subject within the correct flash range when using the built-in flash (p. 163).</li> <li>● Raise the ISO speed and then shoot (p. 81).</li> </ul>
---	--

### **Subject in recorded image is too bright, or image flashes white.**

Subject is too close, making the flash too strong.	<ul style="list-style-type: none"> <li>● Shoot with the subject within the correct flash range when using the built-in flash (p. 163).</li> </ul>
--	---

The subject is overexposed because the surroundings are too dark.	<ul style="list-style-type: none"> <li>● Set the exposure compensation to a negative (-) setting (p. 82).</li> <li>● Use the spot metering functions (p. 83).</li> </ul>
---	--





Too much light is shining directly into the camera, or is being reflected off the subject.	<ul style="list-style-type: none"> <li>● Change the shooting angle.</li> </ul>
--	--

Flash is set to  (Flash on).	<ul style="list-style-type: none"> <li>● Set the flash to  (Flash off) (p. 59).</li> </ul>
---	---



### Image contains noise.

ISO speed is too high.

- Higher ISO speeds and  (High ISO Auto) setting may increase image noise. For higher image quality, use as low an ISO speed as possible (p. 81).
- In the , ,  or  mode, the ISO speed increases and noise can appear.

### White dots appear on the image.

Light from the flash has reflected off dust particles or insects in the air. This is particularly noticeable when shooting using the wide angle.

- This is a phenomenon that occurs with digital cameras and does not constitute a malfunction.

### Eyes appear red.

Light is reflected back from the eyes when the flash is used in dark areas.

- Shoot with [Red-Eye Lamp] in the [Flash Settings] set to [On] (p. 70). For this mode to be effective, the subject must be looking right at the red-eye reduction lamp. Try asking them to look directly at the lamp. Even better results can be obtained by increasing the lighting in indoor settings or approaching closer to the subject. The shutter will not activate for approximately 1 second after the red-eye reduction lamp fires in order to improve the effect.
- If you set the [Red-Eye Corr.] in the [Flash Settings] to [On], the camera will automatically correct red eyes while shooting and record the image to the memory card (p. 70).
- You can correct red eyes in images using the [Red-Eye Correction] function in the  menu (p. 105).

**Continuous shooting slows down.**

The memory card's performance has dropped.

- To enhance the continuous shooting performance, you are recommended to format the memory card in the camera after you save all its images to your computer (p. 122).

**Recording images to memory card takes a long time.**

Memory card was formatted in another device.

- Use a memory card formatted in your camera (p. 122).

**Lens will not retract.**

Memory card slot/battery cover was opened with power on.

- After closing the memory card slot/battery cover, turn the power on then back off.

## Shooting movies

### The recording time may not display properly or shooting may stop unexpectedly.

The following types of memory cards are used.

- Slow recording memory cards.
- Memory cards formatted on a different camera or a computer.
- Memory cards which have had images recorded and erased repeatedly.

- Although the recording time may not display properly during shooting, the movie will be recorded correctly on the memory card. Recording time will display properly if you format the memory card in this camera (excluding slow recording memory cards) (p. 122).



### “!” displayed on the LCD monitor in red and shooting automatically stopped.

There is insufficient free space in the camera's built-in memory.

- Try the following procedures.
  - Format the memory card with a low level format before shooting (p. 122)
  - Lower the recording pixels (p. 74)
  - Use a high-speed memory card (SDC-512MSH, etc.)

### Zoom does not operate.

Zoom button was pressed while shooting in Movie mode.

- Operate the zoom before shooting in Movie mode (p. 54).  
Note that the digital zoom is available while shooting only if  or  is selected in the Standard Movie mode.

## Playback

### Cannot play back.

You attempted to play back images shot with another camera or images edited with a computer.

- Computer images that cannot be played back may play back if they are added to the camera using the supplied software program.

File name was changed with a computer or file location was changed.

- Set the file name or location on the file format/structure of the camera. (Refer to the *Software Starter Guide* for details).

### Movies do not play back correctly.

Movies recorded with high recording pixels may momentarily stop playing if played on slow reading memory cards.

You may experience frame dropping and audio breakup when playing back a movie on a computer with insufficient system resources.

Images shot with this camera may not play back correctly on other cameras.

### Reading images from memory card is slow.

Memory card was formatted in another device.

- Use a memory card formatted in your camera (p. 122).

## TV monitor output

### Image is distorted or not showing on TV monitor.

Incorrect video system setting.

- Set the video system to the appropriate setting, NTSC or PAL, for your TV (p. 50).

## Battery

### Batteries consumed quickly.

Battery performance is insufficient.	<ul style="list-style-type: none"> <li>● Check the battery handling instructions in the <i>Handling Precautions</i> section (p. 150).</li> </ul>
Batteries are not the right type.	<ul style="list-style-type: none"> <li>● Use only unused AA-size alkaline batteries or Canon AA-size NiMH batteries (p. 150).</li> </ul>
Battery capacity drops due to low ambient temperatures.	<ul style="list-style-type: none"> <li>● If shooting in a cold location, warm the batteries such as by placing them in your pocket before using them.</li> </ul>
Battery terminals are dirty.	<ul style="list-style-type: none"> <li>● Wipe the terminals well with a dry cloth before use.</li> <li>● Reload the batteries several times.</li> </ul>

### If using Canon AA-size NiMH batteries.

As the batteries have not been used for over a year, their recharging capacity has decreased.	<ul style="list-style-type: none"> <li>● Their charging performance should return to normal after fully recharging and depleting them over several times.</li> </ul>
Battery life has been exceeded.	<ul style="list-style-type: none"> <li>● Replace both batteries with new ones.</li> </ul>

## Printing with a direct print compatible printer

### Cannot print

The camera and printer are not properly connected.	<ul style="list-style-type: none"> <li>● Securely connect the camera and printer with the specified cable.</li> </ul>
The printer power is not turned on.	<ul style="list-style-type: none"> <li>● Turn on the printer power.</li> </ul>
The print connection method is not correct.	<ul style="list-style-type: none"> <li>● Set [Print Method] to [Auto] (p. 50).</li> </ul>

## List of Messages

The following messages may appear on the LCD monitor during shooting or playback. Please refer to the *Direct Print User Guide* for the messages that display during a printer connection.

### Busy...

Image is being recorded onto the memory card, red-eye correction is being processed, or the camera settings are being reset to the defaults.

### No memory card

You turned on the camera without a memory card installed, or with a memory card installed in the wrong orientation (p. 9).

### Card locked!

The SD memory card or SDHC memory card is write-protected (p. 152).

### Cannot record!

You attempted to shoot an image without a memory card installed, with a memory card installed in the wrong orientation, or attempted to attach a sound memo to a movie.

### Memory card error

There may be something wrong with the memory card. By formatting the malfunctioning memory card with the camera, you may be able to continue using it. However, if this error message appears even when using the supplied memory card, contact your Canon Customer Support Help Desk as there may be a problem with the camera.

### Memory card full

Memory card is full of images and no more can be recorded or saved, or no more image settings, sound recorder files or sound memos can be recorded.

---

### **Naming error!**

The file name could not be created because there is an image with the same name as the folder that the camera is attempting to create, or the highest possible file number has already been reached. In the **[T]** menu, set [File Numbering] to [Auto Reset]; alternatively, save all the images you wish to retain onto a computer, then reformat the memory card. Please note that formatting will erase all the existing images and other data.

### **Change the batteries**

Battery charge is insufficient to operate the camera. Replace both batteries immediately with unused AA-size alkaline batteries or fully charged Canon AA-size NiMH batteries. Check the battery handling instructions in the *Handling Precautions* section (p. 150).

### **No image.**

No images recorded on memory card.

### **Image too large.**

You attempted to play back an image larger than 5616 x 3744 pixels or with a large data size.

### **Incompatible JPEG**

You attempted to play back an incompatible JPEG image (edited with a computer, etc.).

### **RAW**

You attempted to play back an incompatible RAW image.

### **Unidentified Image**

You attempted to play back an image with corrupted data, an image with a recording type specific to another manufacturer's camera, or an image that has been downloaded to a computer and altered.

### **Cannot magnify!**

You attempted to magnify an image recorded in a different camera or data type, an image edited with a computer, or a movie.

**Cannot rotate**

You attempted to rotate the image shot with a different camera or data type, or an image edited with a computer.

**Incompatible WAVE**

A sound memo cannot be added to this image since the data type of the existing sound memo is incorrect. In addition, sound cannot be played back.

**Cannot modify image**

You attempted to resize or perform red eye correction on a movie or an image recorded with another camera. Or you attempted to resize an image recorded using **[W]**, or already resized to **[XS]**.

**Cannot modify**

Cannot apply red-eye correction as no red-eye is detected.

**Cannot transfer!**

When transferring images to your computer using the Direct Transfer menu, you attempted to select an image with corrupted data or an image taken with another camera. You may have also attempted to select a movie when [Wallpaper] was selected in the Direct Transfer menu.

**Protected!**

You attempted to erase a protected image, movie or sound memo.

**Too many marks.**

Too many images have been marked with print settings or transfer settings. Cannot process any more.

**Cannot complete!**

Could not save a part of the print or transfer settings.

**Unselectable image.**

You attempted to set the print settings for a non-JPEG image.

---



### Communication error

The computer was unable to download the image due to the large amount of images (approx. 1000) stored on the memory card. Use a USB card reader or a PCMCIA card adapter to download the images.

### Lens error, restart camera

An error was detected while the lens was in motion, and the power has been automatically turned off. This error can occur if you hold the lens while it is in motion or you operate it in a location with excessive dust or sand in the air. Try turning the power back on, and resume shooting or playback. If this message continues to display, contact your Canon Customer Support Help Desk as there may be a problem with the lens.

### Exx

(xx: number) Camera detected error. Turn the power off and then back on, then shoot or play back. A problem exists if the error code reappears. Note the number and contact your Canon Customer Support Help Desk. If an error code displays directly after taking a picture, the shot may not have been recorded. Check image in Playback mode.

---

## Appendix

### Safety Precautions

- Before using the camera, please ensure that you read the safety precautions described below. Always ensure that the camera is operated correctly.
- The safety precautions noted on the following pages are intended to instruct you in the safe and correct operation of the camera and its accessories to prevent injuries or damage to yourself, other persons and equipment.
- Equipment refers to the camera, battery, battery charger (sold separately) and compact power adapter (sold separately).



### Warnings

#### Equipment

- **Do not point the camera at bright light sources (such as at the sun on a sunny day).**
  - Doing so could damage the camera's CCD.
- **Store this equipment out of the reach of children and infants. Accidental damage by a child could result in serious injury.**
  - Wrist strap: Placement of the strap around the child's neck could result in asphyxiation.
  - Memory card: It may be swallowed accidentally. If this occurs, contact a doctor immediately.

## Equipment

- Do not attempt to disassemble or alter any part of the equipment that is not expressly described in this guide.
- To avoid the risk of high-voltage electrical shock, do not touch the flash portion of the camera if it has been damaged.
- Stop operating the equipment immediately if it emits smoke or noxious fumes.
- Do not allow the equipment to come into contact with, or become immersed in, water or other liquids. If the exterior comes into contact with liquids or salt air, wipe it dry with a soft, absorbent cloth.

Continued use of the equipment may result in fire or electrical shock. Immediately turn the camera power off and remove the camera batteries or unplug the battery charger or compact power adapter from the power outlet. Please consult your camera distributor or the closest Canon Customer Support Help Desk.

- Do not use substances containing alcohol, benzene, thinners or other flammable substances to clean or maintain the equipment.
- Do not cut, damage, alter or place heavy items on the power cord.
- Use only recommended power accessories.
- Remove the power cord on a regular periodic basis and wipe away the dust and dirt that collects on the plug, the exterior of the power outlet and the surrounding area.
- Do not handle the power cord if your hands are wet.

Continued use of the equipment may result in fire or electrical shock.

## Battery

- **Do not place the batteries near a heat source or expose it to direct flame or heat.**
- **The batteries should not be immersed in water or sea water.**
- **Do not attempt to disassemble, alter or apply heat to the batteries.**
- **Avoid dropping or subjecting the batteries to severe impacts that could damage the casing.**
- **Use only recommended batteries and accessories.**

Failure to follow these precautions may cause explosions or leaks, resulting in fire, injury and damage to the surroundings. In the event that a battery leaks and the eyes, mouth, skin or clothing contact these substances, immediately flush with water and seek medical assistance.

- 
- **Never use batteries with a torn exterior seal or visible damage. Always check the seals on store-bought batteries before loading them, as some batteries may come with defective seals. Do not use batteries with defective seals.**

Such batteries may leak, overheat or rupture, and be dangerous.

Never use batteries that look like this.



Batteries with all or part of the seal (electrical insulation sheath) peeled off.



The positive electrode (plus terminal) is flat.



The negative terminal is correctly formed (protruding from the metal base), but the seal does not extend up over the edge of the metal base.

- 
- **Disconnect the battery charger and compact power adapter from both the camera and the power outlet after recharging or when not in use to avoid fire and other hazards.**
  - **Do not place anything, such as tablecloths, carpets, bedding or cushions, on top of the battery charger while it is charging.** Leaving the units plugged in for a long period of time may cause them to overheat and distort, resulting in fire.
-

## Battery

- **When recharging the Canon AA-size NiMH batteries, use only a specified battery charger.**
- **The compact power adapter is designed for exclusive use with this equipment. Do not use it with other products.**  
There is a risk of overheating and distortion which could result in fire or electrical shock.
- **Before you discard a battery, cover the terminals with tape or other insulators to prevent direct contact with other objects.**  
Contact with the metallic components of other materials in waste containers may lead to fire or explosions.

## Others

- **Do not trigger the flash in close proximity to human or animal eyes. Exposure to the intense light produced by the flash may damage eyesight.**  
In particular, remain at least one meter (39 inches) away from infants when using the flash.
- **Keep objects that are sensitive to magnetic fields (such as credit cards) away from the speaker of the camera.**  
Such items may lose data or stop working.



## Cautions

### Equipment

- **Be careful not to entangle the camera in other subjects and not to subject the camera to strong impacts or shocks when holding it by the strap.**
- **Do not bang or apply force to the lens.**  
Such actions could lead to injury or damage the equipment.

---

- **Be careful not to allow dust or sand into the camera when using it at a beach or place with strong winds.**  
It may lead to malfunctions.

---

- **Do not store the equipment in humid or dusty areas.**
- **Do not allow metal objects (such as pins or keys) or dirt to contact the charger terminals or plug.**  
Such conditions could lead to fire, electrical shock or other damage.

---

- **Avoid using, placing or storing the equipment in places subject to strong sunlight or high temperatures, such as the dashboard or trunk (boot) of a car.**
- **Do not use the equipment in a manner that exceeds the rated capacity of the electrical outlet or wiring accessories. Or, do not use the equipment if the cable or plug is damaged, or if the plug is not fully inserted into the power outlet.**
- **Do not use in locations with poor ventilation.**  
The above-mentioned can cause leakage, overheating or explosion, resulting in fire, burns or other injuries. High temperatures may also cause deformation of the casing.

---

- **When not using the camera for extended periods of time, remove the batteries from the camera or battery charger and store the equipment in a safe place.**  
If the batteries are left inside the camera, damage caused by leakage may occur.

---

## Flash

- **Do not operate the flash with dirt, dust or other items stuck to the surface of the flash.**
- **Be careful not to cover the flash with your fingers or clothing when shooting.**

The flash may be damaged and emit smoke or noise. The resulting heat build-up could damage the flash.

- **Do not touch the surface of the flash after taking several pictures in rapid succession.**

Doing so could result in burns.

## Handling Precautions

### Camera

#### **Avoid Strong Magnetic Fields**

- **Never place the camera in close proximity to electric motors or other equipment generating strong electromagnetic fields.**  
Exposure to strong magnetic fields may cause malfunctions or corrupt image data.

#### **Avoid Condensation Related Problems**

- **When moving the equipment rapidly from cold to hot temperatures, you can avoid condensation by placing the equipment in an airtight, resealable plastic bag and letting it adjust to temperature changes slowly before removing it from the bag.**  
Moving the equipment rapidly from cold to hot temperatures may cause condensation (water droplets) to form on its external and internal surfaces.

### Battery

- **This camera uses AA-size alkaline batteries or Canon AA-size NiMH batteries (sold separately).**  
While it is possible to use AA-size nickel-cadmium batteries, performance is unreliable and their use is not recommended.
- **Since the performance of alkaline batteries may differ according to brand, the operating time of the batteries you purchase may not be as long as the batteries that came with the camera.**
- **When using the camera under low temperature conditions or over long periods, you are recommend to use Canon AA-size NiMH batteries (sold separately).**  
Camera operating time may shorten at low temperatures when alkaline batteries are used. Also due to their specifications, alkaline batteries may expire faster than NiMH batteries.
- **Never mix unused and partially used batteries.**  
The partially used batteries may leak.



## Battery

- **Do not install the batteries with their terminals (⊕ and ⊖) reversed.**

- **Do not mix batteries of different types or from different manufacturers.**

- **Before installing the batteries, wipe the battery terminals well with a dry cloth.**

If the battery terminals are soiled with oil from one's skin or other dirt, the number of recordable images may be considerably diminished, or the amount of time the camera can be used may be reduced.

- **At low temperatures, battery performance may be reduced and the low battery icon (🔋) may appear earlier than usual.**

Under these conditions, restore the battery performance by warming it in a pocket immediately before use.

- **Do not put the batteries into a pocket together with metallic items such as a key ring.**

The batteries may be short circuited.

- **When not using the camera for long periods, remove the batteries from the camera and store them separately.**

If the batteries are left inside the camera, the camera may become damaged from battery leakage.

## Memory Card

### SD memory card or SDHC memory card Write Protect Tab

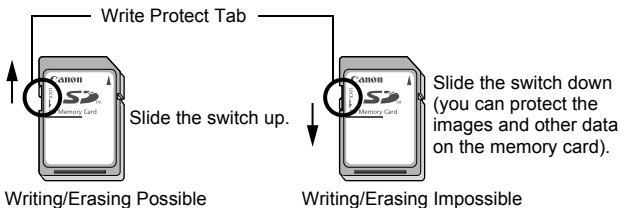

- **Memory cards are high-precision electronic devices. Do not bend them, apply force to them, or subject them to shocks or vibration.**

---

- **Do not attempt to disassemble or alter the memory card.**

---

- **Do not allow dirt, water or foreign objects to contact the terminals on the back of the memory card. Do not touch the terminals with your hands or metal objects.**

---

- **Do not peel away the original label on the memory card or cover it with another label or sticker.**

---

- **When writing on the memory card, do not use a pencil or ball-point pen. Only use a soft point pen (e.g. felt-tip pen).**

---

- **Do not use or store memory cards in the following locations.**
  - Locations subject to dust or sand
  - Locations subject to high humidity and high temperatures

---

- **Since some or all of the data recorded on the memory card may be corrupted or erased by electrical noise, static electricity, camera or memory card malfunction, making a backup copy of important data is recommended.**

---

- **Please note that formatting (initializing) a memory card erases all data, including protected images.**

---

## Memory Card

- **You are recommended to use memory cards that have been formatted in your camera.**
    - The memory card supplied with the camera may be used without further formatting.
    - When the camera is malfunctioning, a corrupted memory card might be the cause. Reformatting the memory card may solve the problem.
    - When a non-Canon brand memory card is malfunctioning, reformatting it may solve the problem.
    - Memory cards formatted in other cameras, computers, or peripheral devices may not operate correctly in this camera. When that happens, reformat the memory card with this camera.

---

  - **If formatting in the camera does not work properly, turn the camera off and re-insert the memory card. Then turn the camera back on and format again.**

---

  - **Be careful when transferring or disposing of a memory card. Formatting or erasing the data on a memory memory card merely changes the file management information on the card and does not ensure that its contents are completely deleted. When disposing of a memory card, take precautions, such as physically destroying the memory card, to prevent personal information leaks.**
-

## Using the Power Kits (Sold Separately)

### Using Rechargeable Batteries (Battery and Charger Kit CBK4-300)

This kit includes a battery charger and four rechargeable AA-size NiMH (nickel metal hydride) batteries. Charge batteries as shown below. Recharging is also possible using two batteries.

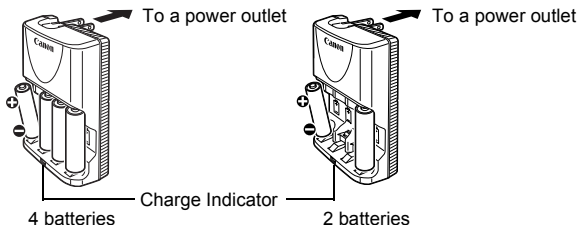

- After inserting the batteries, plug the charger (CB-5AH) into an outlet, or attach the power cord to the charger (CB-5AHE, not shown) and plug the other end into an outlet.
- Do not insert and charge additional batteries once charging has begun.
- The charge indicator blinks while charging, then remains lit when charging is finished.



- The CB-5AH/CB-5AHE battery charger can only be used to charge Canon AA-size NiMH NB-3AH batteries.
- Do not mix batteries with different purchase dates or different charge states. When recharging batteries, always recharge both of them at the same time.
- Do not attempt to recharge fully charged batteries, as doing so may reduce or impair battery performance. Also, do not charge batteries for more than 24 consecutive hours.
- Do not recharge batteries in enclosed areas that tend to retain heat.
- Do not recharge the batteries until the LCD monitor displays the "Change the batteries" message. Repeatedly recharging batteries before they become depleted may cause batteries to lose capacity.



- Wipe the battery terminals well with a dry cloth in the following situations, as the terminals may be soiled with oil from one's skin or other dirt:
  - If the battery usage time has considerably diminished
  - If the number of recordable images has considerably diminished
  - When charging the batteries (insert and remove the batteries two or three times before charging)
  - When charging completes in a space of a few minutes (the battery charger indicator remains lit)
- You may not be able to fully charge the batteries due to their specifications right after purchase or after long periods of nonuse. If this happens, after fully charging them, use the batteries until their charge is depleted. After doing this several times, battery performance will be restored.
- If you store batteries for a long period of time (about 1 year), it is recommended that you deplete the batteries in the camera and to then store them at room temperature (0 to 30°C/32 to 90°F) in low humidity. Storing them in a fully charged condition can shorten their lifespan or degrade their performance.

Again, if you do not use batteries for more than 1 year, fully charge them once a year and deplete them in the camera before storing them.
- If the battery usage time has become considerably low despite wiping the terminals and charging them until the battery charger indicator remains lit, this may indicate that the batteries have reached the end of their lifespan. Replace them with new batteries. If you are purchasing new batteries, look for Canon AA-size NiMH batteries.
- Leaving batteries in the camera or charger may result in damage from battery leakage. When not in use, remove the batteries from the camera or charger and store them in a cool, dry location.



- It takes approximately 4 hours 40 minutes for the charger to fully recharge the batteries after they have been depleted. When two batteries are placed on each side of the charger, recharging will take approximately two hours (as determined by testing at Canon facilities). Charge batteries in an environment where the temperature is in the range of 0 to 35°C (32 to 95°F).
- The charging time varies according to the ambient temperature and to the battery charge state.
- The battery charger may emit noise while charging. This is not a malfunction.

## Using the AC Adapter Kit ACK800

It is best to power the camera with AC Adapter Kit ACK800 (sold separately) when you are using it for long periods of time or connecting it to a computer.



Turn the camera power off before connecting or disconnecting the AC adapter.

- 1 Connect the power cord to the compact power adapter first and then plug the other end into the power outlet.**

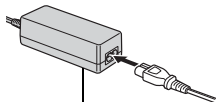

Compact Power Adapter CA-PS800

- 2 Open the terminal cover and attach the cord to the DC IN terminal.**

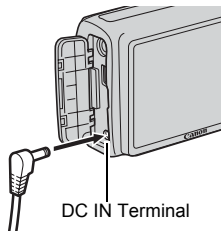

DC IN Terminal

## Using an Externally Mounted Flash (Sold Separately)

### High-Power Flash HF-DC1

This flash is used to supplement the camera's built-in flash when the subject is too far away for proper illumination. Use the following procedures to affix the camera and High-Power Flash to the supporting bracket.

Please read the instructions accompanying the flash along with this explanation.

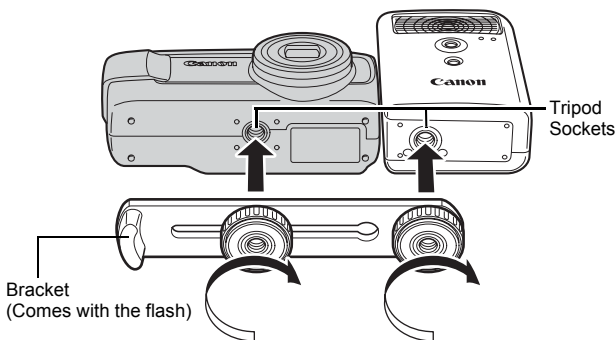

- The flash charge time will lengthen as the battery charge gets weaker. Always set the power/mode switch to [OFF] when you finish using the flash.
- Be careful not to touch the flash window or sensor windows with your fingers while the flash is in use.
- The flash may fire if another flash is being used in close proximity.
- The High-Power Flash may not fire outdoors in daylight or when there are no reflective items.
- For continuous shooting, although the flash fires for the first shot, it does not fire for subsequent shots.
- Fasten the attachment screws securely so that they do not loosen. Failure to do so may lead to the dropping of the camera and flash resulting in damage to both.



- Before attaching the bracket to the flash, check that the lithium battery (CR123A or DL123) is installed.
- To illuminate the subjects properly, install the flash so that it is up against the side of the camera and parallel with the camera's front panel.
- A tripod can be used even when the flash is attached.

## ■ Batteries

### ● Charge becomes Severely Limited

If the battery usage time has considerably diminished, wipe the battery terminals well with a dry cloth. The terminals may be dirty from fingerprints.

### ● Usage in Cold Temperatures

Get a spare generic lithium battery (CR123A or DL123). You are recommended to place the spare battery in your pocket to warm it up before switching it for the battery in the flash.

### ● Non-Use over Extended Periods

Leaving batteries in the High-Power Flash could allow the battery fluid to leak, damaging the product. Remove the batteries from the High-Power Flash and store them in a cool, dry place.



## Replacing the Date Battery

If the Date/Time menu appears when the camera power is turned on, the date battery charge is low and the date and time settings have been lost. Please purchase a lithium coin battery (CR1220) and replace it as follows.

**Please note that the first date battery may appear to expire relatively quickly after you purchase the camera. This is because it is installed in the camera at the point of manufacture, not when you make the purchase.**



Be particularly careful to keep the date batteries out of the reach of children. Seek medical assistance immediately if a child swallows a battery since corrosive battery fluids can damage the stomach or intestinal walls.

- 1 Confirm that the camera is turned off.**
- 2 Slide the battery cover lock and open the cover (p. 9).**
- 3 Hook your nail onto the date battery holder and lightly pull it up.**



- 4 Remove the battery holder in the direction of the arrow.**

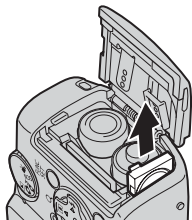

- 5 Remove the battery by pulling it up in the direction of the arrow.**

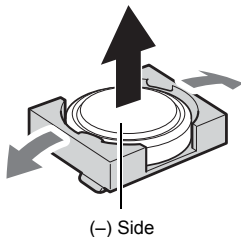

- 6 Insert a new battery with the (–) side facing up.**
- 7 Replace the battery holder and close the cover.**
- 8 When the Date/Time menu appears, set the date and time (p. 12).**



After purchasing the camera and turning on the power for the first time, although the Date/Time menu will appear, you do not need to replace the date battery.

If you ever dispose of your camera, first remove the date battery for recycling according to the recycling system of your country.

## Camera Care and Maintenance



Never use thinners, benzine, detergents or water to clean the camera. These substances may distort or damage the equipment.

### Camera Body

Gently wipe dirt off the camera body with a soft cloth or eyeglass lens wiper.

### Lens

First use a lens blower brush to remove dust and dirt, then remove any remaining dirt by wiping the lens lightly with a soft cloth.



Never use organic solvents on the camera body or lens. If dirt remains, contact the closest Canon Customer Support Help Desk as listed in the European Warranty System (EWS) Booklet.

### LCD Monitor

Use a lens blower brush to remove dust and dirt. If necessary, gently wipe with a soft cloth or an eyeglass lens wiper to remove stubborn dirt.



Never rub or press strongly on the LCD monitor. These actions may damage it or lead to other problems.

## Specifications

All data is based on Canon's standard testing methods. Subject to change without notice.

### PowerShot A470

(W): Max. wide angle (T): Max. telephoto

Camera Effective Pixels	Approx. 7.1 million
Image Sensor	1/2.5-inch type CCD (Total number of pixels: Approx. 7.4 million)
Lens	6.3 (W) – 21.6 (T) mm (35mm film equivalent: 38 (W) – 132 (T) mm) f/3.0 (W) – f/5.8 (T)
Digital Zoom	Approx. 4.0x (Up to approx. 14x in combination with the optical zoom)
LCD Monitor	2.5-inch type TFT color LCD, approx. 115,000 dots (Picture coverage 100%)
AF System	TTL autofocus Focusing frame: Face Detect* <sup>1</sup> * <sup>2</sup> /AiAF(9-points)/Center * <sup>1</sup> AF frame can be moved and fixed to specified face. * <sup>2</sup> If no face is detected, AiAF (9-points) is used.
Focusing Range	Normal: 47 cm (1.5 ft.) – infinity Macro: 5 – 47 cm (2.0 in. – 1.5 ft.) (W), 25 – 47 cm (9.8 in. – 1.5 ft.) (T) Super Macro: 1 – 10 cm (0.39 – 3.9 in.) (W) Infinity: 3 m (9.8 ft.) – infinity Kids&Pets: 1 m (3.3 ft.) – infinity
Shutter	Mechanical shutter and electronic shutter
Shutter Speeds	1/60 – 1/2000 sec. 15 – 1/2000 sec. (Shutter speed range throughout all shooting modes) • Slow shutter speeds of 1.3 sec. or slower operate with noise reduction.
Metering System	Evaluative* <sup>1</sup> , Center-weighted average or Spot* <sup>2</sup> * <sup>1</sup> Facial brightness is also evaluated in Face Detect AF. * <sup>2</sup> Fixed to center
Exposure Compensation	±2 stops in 1/3-stop increments

ISO speed (Standard Output Sensitivity, Recommended Exposure Index)	Auto* <sup>1</sup> , High ISO Auto* <sup>2</sup> , ISO 80/100/200/400/ 800/1600 *1 Camera automatically sets the optimal speed according to shooting mode and subject brightness. *2 Camera automatically sets the optimal speed according to shooting mode, subject brightness and subject movement. However, the ISO speed is set relatively higher than Auto.
White Balance	Auto*, Day Light, Cloudy, Tungsten, Fluorescent, Fluorescent H, Custom * The colors of faces are evaluated in Face Detect AF.
Built-in Flash	Auto, On, Off • Facial brightness is also evaluated in Face Detect AF.
Built-In Flash Range	30 cm – 3.0 m (12 in. – 9.8 ft.) (W), 30 cm – 2.0 m (12 in. – 6.6 ft.) (T) • Brightness of image periphery may reduce depending on shooting distance.
Shooting Modes (Still Images)	Auto, Manual* <sup>1</sup> , Super Macro* <sup>2</sup> , Special Scene* <sup>3</sup> *1 Long shutter mode available *2 Selectable in Manual mode *3 Portrait, Night Snapshot, Kids&Pets, Indoor, Sunset, Foliage, Snow, Beach, Fireworks and Aquarium
(Movies)	Standard, Compact
Continuous Shooting	Approx. 1.9 shots/sec.
Self-timer	Activates shutter after an approx. 10-sec./ approx. 2-sec. delay, Custom Timer
Recording Media	SD memory card, SDHC memory card, MultiMediaCard, MMCplus card, HC MMCplus card
File Format	Design rule for Camera File System and DPOF compliant

Data Type (Still images)	Exif 2.2 (JPEG)* Sound memos: WAVE (monaural)
(Movies)	AVI (Image data: Motion JPEG; Audio data: WAVE (monaural)) * This digital camera supports Exif 2.2 (also called "Exif Print"). Exif Print is a standard for enhancing the communication between digital cameras and printers. By connecting to an Exif Print-compliant printer, the camera's image data at the time of shooting is used and optimized, yielding extremely high quality prints.
Compression	Superfine, fine, normal
Number of Recording Pixels	Large: 3072 x 2304 pixels Medium 1: 2592 x 1944 pixels Medium 2: 2048 x 1536 pixels Medium 3: 1600 x 1200 pixels Small: 640 x 480 pixels Date Stamp: 1600 x 1200 pixels Widescreen: 3072 x 1728 pixels
(Still images)	
(Movies)	Standard: 640 x 480 pixels (20 frames/sec.) 640 x 480 pixels (20 frames/sec. LP) 320 x 240 pixels (30 frames/sec.) Recording can continue until the memory card is full* <sup>1</sup> (can record up to a maximum of 4 GB at one time)* <sup>2</sup> Compact: (can record for 3 min.) 160 x 120 pixels (15 frames/sec.) * <sup>1</sup> Using super high-speed memory cards (SDC-512 MSH recommended). * <sup>2</sup> Even if the file size has not reached 4 GB, the recording is stopped when the recording time reaches one hour. Depending on memory card capacity and data write speed, recording may stop before the file size reaches 4 GB or the recording time reaches one hour.
Playback Modes	Single (histogram displayable), Index (9 images), Magnified (approx. 2-10x), Resume Playback, My Category, Jump, Movie (slow motion playback possible), Rotate, Slide Show, Red-Eye Correction, Resize, Sound memos (recording and playing back possible up to 1min.), Protect.

Direct Print	<i>PictBridge</i> compliant, <i>Canon Direct Print</i> and <i>Bubble Jet Direct</i> compatible
Interface	USB (mini-B) Audio/Video output (NTSC or PAL selectable, monaural audio)
Communication Settings	MTP, PTP
Power Source	2 AA-size alkaline batteries 2 AA-size NiMH batteries NB4-300 (sold separately) AC Adapter Kit ACK800 (sold separately)
Operating Temperatures	0 – 40 °C (32 – 104 °F) (0 – 35 °C (32 – 95 °F) when NB-3AH is used.)
Operating Humidity	10 – 90%
Dimensions (excluding protrusions)	104.8 x 55.1 x 40.7 mm (4.13 x 2.17 x 1.60 in.)
Weight (camera body only)	Approx. 165 g (5.82 oz.)

## Battery Capacity

	Number of Images Shot	Playback Time
	LCD Monitor On (Based on the CIPA standard)	
<b>AA-size Alkaline Batteries (included with the camera)</b>	Approx. 150 shots	Approx. 6 hours
<b>AA-size NiMH Batteries (NB-3AH (fully charged))</b>	Approx. 400 shots	Approx. 8 hours

- The actual figures will vary according to the shooting conditions and settings.
- Movie data is excluded.
- At low temperatures, the battery performance may diminish and the low battery icon may appear very rapidly. In these circumstances, the performance can be improved by warming the battery in a pocket before use.

## Test Conditions

Shooting: Normal temperature (23°C ±2°C/73°F ±3.6°F), normal relative humidity (50% ±20%), alternating wide angle end and telephoto end shots at 30 second intervals with the flash fired once every two shots and the camera power turned off after every tenth shot. Power is left off for a sufficient amount of time\*, then the power is turned back on and the testing procedure is repeated.

- A Canon-brand memory card is used.

- \* Until the battery returns to normal temperature

Playback: Normal temperature (23°C ±2°C/73°F ±3.6°F), normal relative humidity (50% ±20%), continuous playback at 3 seconds per image.























See *Handling Precautions* (p. 150).



## Memory Cards and Estimated Capacities







: Memory Card included with the camera

Recording Pixels	Compression	32MB	SDC-128M	SDC-512MSH
<b>L</b> (Large) 3072 x 2304 pixels		9	40	156
		15	64	251
		32	134	520
<b>M1</b> (Medium 1) 2592 x 1944 pixels		11	49	190
		20	87	339
		41	173	671
<b>M2</b> (Medium 2) 2048 x 1536 pixels		18	76	295
		32	136	529
		64	269	1041
<b>M3</b> (Medium 3) 1600 x 1200 pixels		29	121	471
		52	217	839
		99	411	1590
<b>S</b> (Small) 640 x 480 pixels		111	460	1777
		171	711	2747
		270	1118	4317
 (Date Stamp) 1600 x 1200 pixels		52	217	839
<b>W</b> (Widescreen) 3072 x 1728 pixels		12	53	207
		20	86	335
		42	177	686

-  Capable of smooth continuous shooting (p. 69) when the memory card has been formatted with a low level format.
- This reflects standard shooting criteria established by Canon. Actual results may vary according to the subject and shooting conditions.





## Movie







□: Memory Card included with the camera

		Recording Pixels /Frame Rate	32MB	SDC-128M	SDC-512MSH
 Standard		640 x 480 pixels 20 frames/sec.	22 sec.	1 min. 36 sec.	6 min. 12 sec.
		640 x 480 pixels 20 frames/sec. LP	45 sec.	3 min. 10 sec.	12 min. 16 sec.
		320 x 240 pixels 30 frames/sec.	43 sec.	3 min. 1 sec.	11 min. 42 sec.
 Compact		160 x 120 pixels 15 frames/sec.	3 min. 30 sec.	14 min. 29 sec.	55 min. 57 sec.

- Maximum movie clip length at : 3 min. The figures indicate the maximum continuous recording time.

## Image Data Sizes (Estimated)

Recording Pixels	Compression		
			
<b>L</b> 3072 x 2304 pixels	3045 KB	1897 KB	902 KB
<b>M1</b> 2592 x 1944 pixels	2503 KB	1395 KB	695 KB
<b>M2</b> 2048 x 1536 pixels	1602 KB	893 KB	445 KB
<b>M3</b> 1600 x 1200 pixels	1002 KB	558 KB	278 KB
<b>S</b> 640 x 480 pixels	249 KB	150 KB	84 KB
 1600 x 1200 pixels	—	558 KB	—
<b>W</b> 3072 x 1728 pixels	2304 KB	1420 KB	678 KB

	Frame Rate/Recording Pixels		File size
 Standard		640 x 480 pixels, 20 frames/sec.	1280 KB/sec.
		640 x 480 pixels, 20 frames/sec. LP	640 KB/sec.
		320 x 240 pixels, 30 frames/sec.	660 KB/sec.
 Compact		160 x 120 pixels, 15 frames/sec.	120 KB/sec.

### MultiMediaCard

Interface	Compatible with MultiMediaCard standards
Dimensions	32.0 x 24.0 x 1.4 mm (1.3 x 0.9 x 0.06 in.)
Weight	Approx. 1.5 g (0.05 oz.)

### SD Memory Card

Interface	Compatible with SD memory card standards
Dimensions	32.0 x 24.0 x 2.1 mm (1.3 x 0.9 x 0.1 in.)
Weight	Approx. 2 g (0.07 oz.)

### NiMH Battery NB-3AH

(Supplied with the separately sold NiMH Battery NB4-300 set or the Battery and Charger Kit CBK4-300)

Type	AA-size nickel metal hydride battery
Nominal Voltage	1.2 V DC
Typical Capacity	2500 mAh (min.: 2300 mAh)
Cycle Life	Approx. 300 times
Operating Temperatures	0 – 35 °C (32 – 95 °F)
Dimensions	Diameter: 14.5 mm (0.57 in.) Length: 50.0 mm (1.97 in.)
Weight	Approx. 30 g (1.06 oz.)

### Battery Charger CB-5AH/CB-5AHE

(Supplied with the separately sold Battery and Charger Kit CBK4-300)

Rated Input	100 – 240 V AC (50/60 Hz)
Rated Output	565 mA x 4, 1275 mA x 2
Charging Time	Approx. 4 hours 40 min.* <sup>1</sup> , Approx. 2 hours* <sup>2</sup>
Operating Temperatures	0 – 35 °C (32 – 95 °F)
Dimensions	65.0 x 105.0 x 27.5 mm (2.56 x 4.13 x 1.08 in.)
Weight (body only)	Approx. 95 g (3.35 oz.)

\*1 When charging four NB-3AH batteries

\*2 When charging two NB-3AH batteries loaded one on each side of the battery charger

### Compact Power Adapter CA-PS800

(Included with the separately sold AC Adapter Kit ACK800)

Rated Input	100 – 240 V AC (50/ 60 Hz)
Rated Output	3.15 V DC, 2.0 A
Operating Temperatures	0 – 40 °C (32 – 104 °F)
Dimensions	42.6 x 104.0 x 31.4 mm (1.68 x 4.09 x 1.24 in.)
Weight	Approx. 180 g (6.35 oz.) (excluding power cord)

# Index

## Numerics

3:2 Guide ..... 91

## A

AC Adapter Kit ACK800 ..... 156

Accessories ..... 34

AF Frame ..... 44, 76

AF-assist Beam ..... 47

AF-Point Zoom ..... 75

AiAF ..... 76

Auto Category ..... 92

Auto Mode ..... 14

Auto Rotate Function ..... 127

AV cable ..... 129

## B

### Battery

Battery Capacity ..... 166

Charge Indicator ..... 44

Charging ..... 154

Installing ..... 9

## C

### Camera Direct

Compatible Printer ..... 35

Camera Shake Warning ..... 44, 132

Components Guide ..... 38

Compression ..... 65

### Computer

Connecting ..... 27

Downloading Images ..... 25

System Requirements ..... 25

Continuous Shooting ..... 69

Create Folder ..... 125

## D

Date Battery ..... 159

Date Stamp ..... 20

Date/Time ..... 12

Digital Tele-Converter ..... 55

Digital Zoom ..... 55

Direct Transfer ..... 29

Display Off ..... 121

Display Overlays ..... 91

DPOF ..... 115, 119

## E

### Erasing

All Images ..... 114

Single Images ..... 17

Exif Print ..... 164

Exposure Compensation ..... 82

## F

Face Detect ..... 76

Face Select and Track ..... 78

File Number ..... 123

### Flash

Settings ..... 70

Shooting ..... 59

Focus ..... 15, 76

Focus Lock ..... 80

Frame Rate ..... 74

## G

Grid Lines ..... 91

## H

High-Power Flash HF-DC1 ..... 157

Histogram ..... 46

- I**
- Index Playback ..... 97
  - Indicator ..... 40, 41
  - Infinity ..... 60
  - Info Disp. .... 45, 51
  - ISO Speed ..... 81
- J**
- Jump (Image Search) ..... 99
- L**
- Language ..... 13
  - LCD Monitor ..... 44, 51
  - Lens Retract ..... 50
  - List of Messages ..... 140
  - Long Shutter Mode ..... 84
- M**
- Macro ..... 60
  - Magnifying Images ..... 96
  - Memory Card
    - Estimated Capacities ..... 167
    - Formatting ..... 122
  - Menu
    - FUNC. Menu ..... 42, 46
    - Menus and Settings ..... 42, 43
    - Play Menu ..... 48
    - Print Menu ..... 48
    - Rec. Menu ..... 47
    - Set up Menu ..... 49
  - Metering Modes ..... 83
  - Microphone ..... 38
  - Mode Dial ..... 14, 40
  - Movie ..... 22
    - Shooting ..... 22, 72
    - Viewing ..... 24, 100
  - Mute ..... 49
  - My Category ..... 98
  - My Colors ..... 89
- N**
- Night Display ..... 53
- O**
- Overexposure Warning ..... 45
- P**
- Power Kits ..... 154
  - Power Saving ..... 121
  - Print List ..... 19
  - Print Method ..... 50
  - Print Settings (DPOF) ..... 115
  - Print Style ..... 115
  - Print/Share Button ..... 18, 29, 93
  - Printing ..... 18
  - Protect ..... 113
- R**
- Rec. Review ..... 15
  - Recording Pixels ..... 64, 74
  - Red-Eye ..... 70
  - Red-Eye Correction
    - (Playback) ..... 105
    - Red-Eye Correction (Shooting) 70
  - Registering Settings to the
    - Print/Share Button ..... 93
  - Reset All ..... 128
  - Resize ..... 110
  - Review Info ..... 51
  - Rotate ..... 102
- S**
- Safety Zoom ..... 56
  - Self-Timer ..... 62
  - Shooting Info ..... 44, 51
  - Shooting Mode ..... 14, 66, 68, 72
  - Shutter Button ..... 40
    - Fully ..... 15
    - Halfway ..... 14

Shutter Speed .....	44
Slide Show .....	104
Slow Synchro .....	70
Smooth Continuous Shooting ...	69
Sound Memo .....	112
Spot AE Point Frame .....	44, 83
Spot Metering .....	83
Super Macro .....	61
System Map .....	32

## T

Telephoto .....	54
Transfer Settings (DPOF) .....	119
Transition Effects .....	103

## V

Vertical Shutter Release .....	95
Video System .....	129
Volume .....	101, 112

## W

White Balance .....	86
Wide Angle .....	54
Wrist Strap .....	11
Write Protect Tab .....	152

## Z

Zoom	
Digital Zoom .....	55
Optical Zoom .....	54



## **Disclaimer**





- While every effort has been made to ensure that the information contained in this guide is accurate and complete, no liability can be accepted for any errors or omissions.
- Canon reserves the right to change the specifications of the hardware and software described herein at anytime without prior notice.
- No part of this guide may be reproduced, transmitted, transcribed, stored in a retrieval system, or translated into any language in any form, by any means, without the prior written permission of Canon.
- Canon makes no warranties for damages resulting from corrupted or lost data due to a mistaken operation or malfunction of the camera, the software, SD memory cards (SD cards), personal computers, peripheral devices, or use of non-Canon SD cards.

## **Trademark Acknowledgments**

- Microsoft, Windows Vista and the Windows Vista logo are trademarks or registered trademarks of Microsoft Corporation in the United States and/or other countries.
- Macintosh, the Mac logo, QuickTime and the QuickTime logo are trademarks of Apple Inc., registered in the U.S. and other countries.
- The SDHC logo is a trademark.

## Functions Available in Each Shooting Mode

Some functions may not be available, depending on the shooting mode. Check the functions available for each shooting mode in the table below.

Function						
			Long Shutter			
Exposure Compensation (p. 82)		○	–	○	–	
Long Shutter (p. 84)		–	○	–	–	
ISO Speed (p. 81)	Auto* <sup>1</sup>	○	–	○	○	
	High ISO Auto* <sup>1</sup>	○	–	○	○	
	ISO 80–1600	○	○	○	–	
White Balance (p. 86)	Auto* <sup>1</sup>	○	○	○	○	
	Other than Auto	○	○	○	–	
Drive Mode (pp. 62, 69)	Single Shot	○	○	○	○	
	Continuous	○	○	○	–	
	Self Timer	2 sec./10 sec.	○	○	○	○
		Custom	○	○	○	○
Self-Timer (Delay, Shots) (p. 63)		○	○	○	○	
My Colors (p. 89)		○	○	○	–	
Recording Pixels/Compression (still images) (p. 64)		○	○	○	○	
Date Stamp (p. 20)		○	○	○	○	
Recording Pixels/ Frame Rate (movies) (p. 74)	640 x 480, 20 fps/20 fps LP	–	–	–	–	
	320 x 240, 30 fps	–	–	–	–	
	160 x 120, 15 fps	–	–	–	–	
Shooting Zone (p. 60)	Normal	○	○	–	○	
	Macro	○	○	–	○	
	Infinity	○	○	–	–	
Face Select and Track (p. 78)		○	○	○	○	
Flash (p. 59)	Auto	○	–	–	○	
	On	○	○	–	–	
	Off	○	○	○	○	



Function		CAM			📷
		📷	Long Shutter	📷	📷
AF Frame (p. 76)	Face Detect	○	○	○	○
	AiAF (9-points)	○	○	○	○
	Center	○	○	○	○
AF-Point Zoom (p. 75)		○	○	○	○
Digital Zoom *2 (p. 55)	Standard	○	○	○	○
	Digital Tele-converter	○	○	○	○
Flash Settings (p. 70)	Slow Synchro	○	○ <sup>*3</sup>	–	–
	Red-Eye Correction	○	○	–	○
	Red-Eye Lamp	○	○	–	○
Metering System (p. 83)	Evaluative	○	○	○	○
	Center-weighted Avg.	○	–	○	–
	Spot	○	–	○	–
AF-assist Beam (p. 47)		○	○	○	○
Shooting Info (p. 51)	Off	○	○	○	○
	On	○	○	○	○
Review (Rec. Review) (p. 15)		○	○	○	○
Review Info (p. 51)	Off	○	○	○	○
	Detailed	○	○	○	○
Auto Category (p. 92)		○	○	○	○
Disp. Overlay (p. 91)	Grid Lines	○	○	○	○
	3:2 Guide/Both	○	○	○	○
Registering settings to the Print Share button (p. 93)		○	○	○	○

○ : Setting available or optimum value is automatically set by the camera.

– : Not available.

\*1 Set to optimum value depending on each shooting mode.

\*2 Date Stamp and Widescreen are not available.

\*3 Always set to [On].

\*4 Only available when the flash is set to [On].





**Canon**