

Canon

CANON INC.
30-2 Shimomaruko 3-chome, Ohta-ku,
Tokyo 146-8501, Japan

Europe, Africa & Middle East
CANON Europa N.V.
PO Box 2262, 1180 EG Amstelveen, The Netherlands

CANON (UK) LTD
For technical support, please contact the Canon Help Desk:
P.O. Box 431, Wallington, Surrey, SM6 0XU, UK
Tel: (08705) 143723 Fax: (08705) 143340
<http://www.canon.co.uk/Support/index.asp>

**CANON COMMUNICATION & IMAGE
FRANCE S.A.**
102 Avenue du Général de Gaulle,
92257 LA GARENNE COLOMBES CEDEX, France
Tél : Hot line 08 25 00 29 23
<http://www.cci.canon.fr>

CANON DEUTSCHLAND GmbH
Postfach 100401, 47704 Krefeld, Germany
Customer Hotline: 0180/5006022 (0,12 € / Min.)
www.canon.de

CANON ITALIA S.P.A.
Via Milano 8, I-20097 San Donato Milanese (MI), Italy
Tel: 02/8248.1 Fax: 02/8248.4604
Pronto Canon: 02/8249.2000
E-mail: supporto@canon.it <http://www.canon.it>

CANON ESPAÑA S.A.
C/ Joaquín Costa, 41 – 28002 Madrid, Spain
Tel. Atención al Cliente: 901.301.301
Help Desk: 906.301.255
<http://www.canon.es>

CEL-SE3BA210

CANON BELGIUM N.V. / S.A.
Bessenveldstraat 7, B – 1831 Diegem, Belgium
Tel.: (02) 722.04.11 Fax: (02) 721.32.74
Helpdesk : 0900-10627
<http://www.canon.be>

CANON LUXEMBOURG S.A.
Rue des Jongs 21, L-1818 Howald, Luxembourg
Tel.: (0352) 48 47 961 Fax: (0352) 48 47 96232
Helpdesk : 900-74100
<http://www.canon.lu>

CANON NEDERLAND N.V.
Neptunusstraat 1, 2132 JA Hoofddorp, The Netherlands
Tel.: 023 – 5 670 123 Fax: 023 – 5 670 124
Helpdesk: 023 – 5 681 681
<http://www.canon.nl>

CANON DANMARK A/S
Knud Højgaard Vej 1, DK-2860 Søborg, Danmark
Phone: +45 44 88 26 66
<http://www.canon.dk>

CANON NORGE AS
Hallagerbakken 110, Postboks 33, Holmlia, 1201 Oslo,
Norway
Tlf: 22 62 93 21 Faks: 22 62 06 15
E-mail: helpdesk@canon.no
<http://www.canon.no>

Finland
CANON OY
Huopalahdentie 24, 00350 Helsinki, Finland
Puhelin: 010 54420 Fax 010 544 30
HelpDesk 020 366 466 (1,47 snt/min + pvm)
(ma-pe klo 9:00 - 17:30)
Sähköposti: helpdesk@canon.fi
Internet: www.canon.fi

© 2004 CANON INC.

CANON SVENSKA AB
Gustav III:s Boulevard 26, S-169 88 Solna, Sweden
Helpdesk: 08-744 8620 Fax 08-744 8527
<http://www.canon.se>

CANON (SCHWEIZ) AG
Industriestrasse 12, 8305 Dietlikon, Switzerland
Consumer Imaging Group
Tel. 01-835-61 61
Hotline 0900 57 55 20 (CHF 2.13/min)
<http://www.canon.ch>

Austria
CANON GES.M.B.H.
Zetschegasse 11, A - 1230 Wien, Austria
Helpdesk Tel.: 01 66 146 412
Fax: 01 66 146 413
<http://www.canon.at>

Portugal
SEQUE – SOC. NAC. EQUIP., S.A.
Pr. Alegria, 58 – 2ºC, 1269-149 Lisboa
Telef: (+351) 21 324 28 30 Fax: (+351) 21 347 27 51
E-mail: info@seque.pt <http://www.seque.pt>

Eastern Europe
CANON CEE GMBH
Oberlaaerstr 233, A-1100 Wien, Austria
Tel.: +43 1 680 88-0 Fax: +43 1 680 88-422

CIS
CANON NORTH-EAST OY
Huopalahdentie 24, 00350 Helsinki, Finland
Tel.: +358 10 544 00 Fax: +358 10 544 10
<http://www.canon.ru>

Printed in the EU

ENGLISH

Canon

PowerShot S1 IS

DIGITAL CAMERA

Camera User Guide

DiGiC



- Please read the *Read This First* section (p. 4).
- Please also see the *Canon Digital Camera Software Starter Guide Disk* and the *Direct Print User Guide*.

Canon DIGITAL CAMERA PowerShot S1 IS Camera User Guide

Disclaimer

- While every effort has been made to ensure that the information contained in this guide is accurate and complete, no liability can be accepted for any errors or omissions.
- Canon Inc. reserves the right to change the specifications of the hardware and software described herein at any time without prior notice.
- No part of this guide may be reproduced, transmitted, transcribed, stored in a retrieval system, or translated into any language in any form, by any means, without the prior written permission of Canon Inc.
- Canon makes no warranties for damages resulting from corrupted or lost data due to a mistaken operation or malfunction of the camera, the software, the CompactFlash™ cards (CF cards), personal computers, peripheral devices, or use of non-Canon CF cards.

Trademark Acknowledgements

- Canon and PowerShot are trademarks of Canon.
- CompactFlash is a trademark of SanDisk Corporation.
- iBook and iMac are trademarks of Apple Computer, Inc.
- Macintosh, PowerBook, Power Macintosh and QuickTime are trademarks of Apple Computer, Inc, registered in the United States and other countries.
- Microsoft, Windows, and Windows NT are either registered trademarks or trademarks of Microsoft Corporation in the United States and/or other countries.
- Other names and products not mentioned above may be registered trademarks or trademarks of their respective companies.

Use of genuine Canon accessories is recommended.

This product is designed to perform optimally when used with genuine Canon accessories. Canon shall not be liable for any damage to this product and/or accidents such as fire, etc., caused by the malfunction of non-genuine Canon accessories (e.g., a leakage and/or explosion of a battery pack). Please note that this warranty does not apply to repairs arising out of the malfunction of non-genuine Canon accessories, although you may request such repairs on a chargeable basis.

* Default setting ○: Setting selection is possible. △: Setting can only be selected for the first image.
—: Setting selection is not possible.

■: Setting remains in effect even when the camera is turned off.
The default for the settings changed by the menu and button operations can be restored all at once except for [Date/Time], [Language] and [Video System] (p. 68).

- (1) Selectable only in manual focus.
- (2) Can be set after AE lock is set.
- (3) AE lock only is available.
- (4) Cannot be adjusted when the photo effect is set to [Sepia] or [B/W].
- (5) The white balance is set to [AUTO].
- (6) The white balance [Flash] cannot be set.
- (7) The ISO speed is automatically set by the camera.
- (8) ISO [AUTO] cannot be selected.

Flowchart and Reference Guides

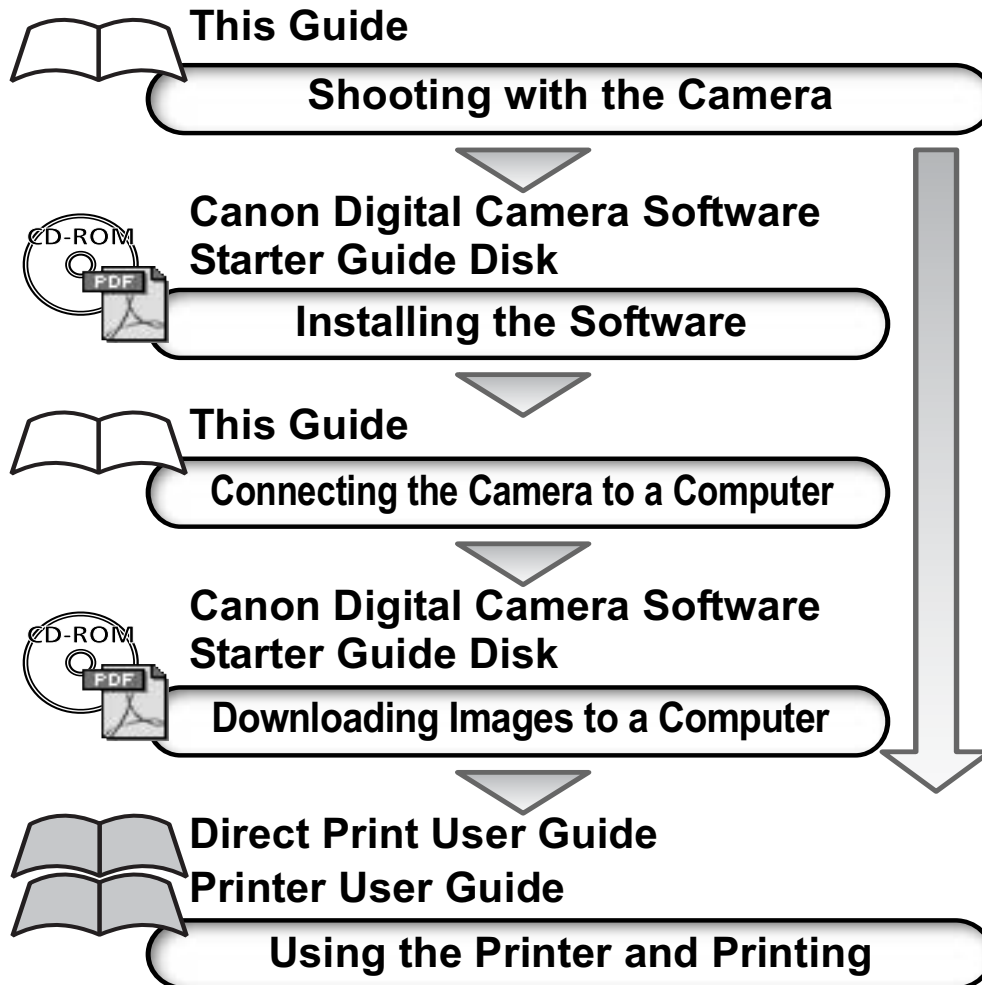

Symbols Used



-  : This mark denotes issues that may affect the camera's operation.
-  : This mark denotes additional topics that complement the basic operating procedures.

Table of Contents

Items marked with ★ are lists or charts that summarize camera functions or procedures.

Read This First

Chapter 1. Preparing the Camera

Components Guide	10
Controls	12
Installing the Batteries/CF Card	14
Turning the Power On/Off.	19
Setting the Date/Time.	21
Setting the Language	23
★ Using the Viewfinder and the LCD Monitor	24

Chapter 2. Shooting-The Basics

★ AUTO Auto Mode	27
Reviewing an Image Right after Shooting	30
Changing the Resolution and Compression.	32
⚡ Using the Built-in Flash.	34

Chapter 3. Playback-The Basics

Displaying Images Individually	39
🔍 Magnifying Images	40
Viewing Images in Sets of Nine (Index Playback)	41
JUMP Jumping Between Images	42

Chapter 4. Erasing

🗑 Erasing Images Individually	43
Erasing All Images	44

Chapter 5. Useful Shooting Functions

Using the Mode Dial (Image Zone)	45
👤 Portrait	
🏞 Landscape	
🌃 Night Scene	
📸 Fast Shutter	
📷 Slow Shutter	
📷 Shooting Panoramic Images (Stitch Assist)	47
⌚ Using the Self-timer	49
Digital Zoom	50
📷 Continuous Shooting	52
🎥 Movie Mode	53
Viewing/Editing Movies	57

Chapter 6. Shooting-Advanced Functions

★ Selecting Menus and Settings	61
Resetting the Settings to Default	68
Registering Settings to the Shortcut Button	69
Using the Mode Dial (Creative Zone).	71
📷 Program AE	
📷 Tv Setting the Shutter Speed	
📷 Av Setting the Aperture	
📷 M Manually Setting the Shutter	
📷 Selecting an AF Frame.	75

☑ Switching between Light Metering Modes	76
Adjusting the Exposure	78
Adjusting the Tone (White Balance)	79
Changing the ISO Speed.	81
Changing the Photo Effect.	82
Auto Exposure Bracketing (AEB Mode)	84
Focus Bracketing (Focus-BKT Mode)	85
Locking the Exposure Setting (AE Lock)	86
Locking the Flash Exposure Setting (FE Lock) . . .	87
Switching between Built-in Flash Adjustment Settings . .	88
Switching the Timing at which the Flash Fires . . .	90
Shooting Images at Set Intervals (Intervalometer) .	91
Shooting Problem Subjects for the Autofocus	93
Switching between Focus Settings	97
C Saving Custom Settings	98

Chapter 7. Playback-Advanced Functions

Rotating Images in the Display	100
🎤 Attaching Sound Memos to Images.	101
Automated Playback (Slide Show)	102
Protecting Images	106

Chapter 8. Camera Settings

Setting the Power Saving Function	107
Setting the Auto Rotate Function.	108
Resetting the File Numbers	110
Customizing the Camera (My Camera Settings). .	111

Chapter 9. Additional Features

Downloading Images to a Computer	115
Downloading Directly from a CF Card	117
Viewing Images on a TV Set	118
About Printing	119
Print Settings (DPOF Print Settings)	121
Image Transmission Settings (DPOF Transfer Order) .	126

Appendix

List of Messages	128
Troubleshooting.	130
Using the Wireless Controller (Sold Separately) .	135
Using Conversion Lenses (Sold Separately). . . .	137
Using the Power Kits (Sold Separately)	140
Replacing the Date Battery	144
Camera Care and Maintenance	145
Specifications	146
Photo Tips and Information	154
Index	157
★Functions Available in Each Shooting Mode. . . .	166

Read This First

Please Read

Test Shots

Before you try to photograph important subjects, we highly recommend that you shoot several trial images to confirm that the camera is operating and being operated correctly. Please note that Canon Inc., its subsidiaries and affiliates, and its distributors are not liable for any consequential damages arising from any malfunction of a camera or accessory, including CompactFlash™ cards, that results in the failure of an image to be recorded or to be recorded in a format that is machine sensible.

Warning Against Copyright Infringement

Please note that Canon digital cameras are intended for personal use and should never be used in a manner that infringes upon or contravenes international or domestic copyright laws and regulations. Please be advised that in certain cases the copying of images from performances, exhibitions, or commercial properties by means of a camera or other device may contravene copyright or other legal rights even if the image was shot for personal use.

Warranty Limitations

For information on your camera's warranty, please refer to the Canon European Warranty System (EWS) Booklet supplied with your camera.

For Canon Customer Support contacts, please see rear of this booklet or the European Warranty System (EWS) Booklet.

Camera Body Temperature

If your camera is used for prolonged periods, the camera body may become warm. Please be aware of this and take care when operating the camera for an extended period.

About the LCD Monitor

The LCD monitor is produced with extremely high-precision manufacturing techniques. More than 99.99% of the pixels operate to specification. Less than 0.01% of the pixels may occasionally misfire or appear as red or black dots. This has no effect on the recorded image and does not constitute a malfunction.

Video Format

Please set the camera's video signal format to the one used in your region before using it with a TV monitor (p. 67).

Language Setting

Please see page 23 to change the language setting. Please read through the "Read This First" section (p. 4) before using your camera.

Safety Precautions

- Before using the camera, please ensure that you read and understand the safety precautions described below. Always ensure that the camera is operated correctly.
- The safety precautions noted on the following pages are intended to instruct you in the safe and correct operation of the camera and its accessories to prevent injuries or damage to yourself, other persons and equipment.
- In the next few pages, the term "equipment" refers primarily to the camera, its batteries, separately sold battery charger and separately sold compact power adapter.



Warnings

- **Do not aim the camera directly into the sun or at other intense light sources** which could damage your eyesight.
- **Do not trigger the flash in close proximity to human or animal eyes.** Exposure to the intense light produced by the flash may damage eyesight. In particular, remain at least one meter (39 inches) away from infants when using the flash.
- **Store this equipment out of the reach of children and infants.** Accidental damage to the camera or batteries by a child could result in serious injury. In addition, placement of the strap around a child's neck could result in asphyxiation.
- **Do not attempt to disassemble or alter any part of the equipment that is not expressly described in this guide.** Disassembly or alteration may result in high-voltage electrical shock. Internal inspections, alterations and repairs should be conducted by qualified service personnel authorized by your camera distributor or a Canon Customer Support Help Desk.
- **To avoid the risk of high-voltage electrical shock, do not touch the flash portion of the camera if it has been damaged.** Similarly, never touch internal portions of the equipment that become exposed as a result of damage. There is a risk of high-voltage electrical shock. Please take the first opportunity to consult your camera distributor or a Canon Customer Support Help Desk.

- **Stop operating the equipment immediately if it emits smoke or noxious fumes.** Failure to do so may result in fire or electrical shock. Immediately turn the camera's power off, remove the batteries and unplug the power cord from the power outlet. Confirm that smoke or fume emissions have ceased. Please consult your camera distributor or the closest canon Customer Support Help Desk.
- **Stop operating the equipment immediately if it is dropped or the casing is damaged.** Failure to do so may result in fire or electrical shock. Immediately turn the camera's power off, remove the batteries or unplug the power cord from the power outlet. Please consult your camera distributor or the closest Canon Customer Support Help Desk.
- **Do not allow the equipment to come into contact with, or become immersed in, water or other liquids.** Do not allow liquids to enter the interior. The camera has not been waterproofed. If the exterior comes into contact with liquids or salt air, wipe it dry with a soft, absorbent cloth. In the event that water or other foreign substances enter the interior, immediately turn the camera's power off and remove the batteries or unplug the power cord from the power outlet. Continued use of the equipment may result in fire or electrical shock. Please consult your camera distributor or the closest Canon Customer Support Help Desk.
- **Do not use substances containing alcohol, benzene, thinners or other flammable substances to clean or maintain the equipment.** The use of these substances may lead to fire.

● **Remove the power cord on a regular periodic basis and wipe away the dust and dirt that collects on the plug, the exterior of the power outlet and the surrounding area.** In dusty, humid or greasy environments, the dust that collects around the plug over long periods of time may become saturated with humidity and short-circuit, leading to fire.

● **Do not cut, damage, alter or place heavy items on the power cord.** Any of these actions may cause an electrical short circuit, which may lead to fire or electrical shock.

● **Do not handle the power cord if your hands are wet.** Handling it with wet hands may lead to electrical shock. When unplugging the cord, ensure that you hold the solid portion of the plug. Pulling on the flexible portion of the cord may damage or expose the wire and insulation, creating the potential for fires or electrical shocks.

● **Use only the recommended power accessories.** Use of power sources not expressly recommended for this equipment may lead to overheating, distortion of the equipment, fire, electrical shock or other hazards.

● **Do not place the batteries near a heat source or expose them to direct flame or heat.** Neither should you immerse them in water. Such exposure may damage the batteries and lead to the leakage of corrosive liquids, fire, electrical shock, explosion or serious injury.

● **Do not attempt to disassemble, alter or apply heat to the batteries.** There is serious risk of injury due to an explosion. Immediately flush with water any area of the body, including the eyes and mouth, or clothing that comes into contact with the inner contents of a battery. If the eyes or mouth contact these substances, immediately flush with water and seek medical assistance.

● **Avoid dropping or subjecting the batteries to severe impacts that could damage the casings.** It could lead to leakage and injury.

● **Do not short-circuit the battery terminals with metallic objects, such as key holders.** It could lead to overheating, burns and other injuries.

● **Before you discard a battery, cover the terminals with tape or other insulators to prevent direct contact with other objects.** Contact with the metallic components of other materials in waste containers may lead to fire or explosion. Discard the batteries in specialized waste facilities if available in your area.

● **Please use Canon AA-size NiMH batteries and charger recommended for use with these batteries.** Use of another charger may cause batteries to overheat or deform, posing risk of fire injury and damage to the surroundings.

● **Disconnect the battery charger or the compact power adapter from both the camera and power outlet after recharging and when the camera is not in use** to avoid fires and other hazards.

● **The camera terminal of the separately sold compact power adapter is designed for exclusive use with your camera.** Do not use it with other products or batteries. There is a risk of fire and other hazards.

-
- **Exercise due caution when screwing on the separately sold wide converter, tele-converter and conversion lens adapter.** If they loosen, fall off and shatter, the glass shards may cause an injury.
-



CAUTIONS

-
- **Avoid using, placing or storing the equipment in places subject to strong sunlight or high temperatures, such as the dashboard or trunk (boot of a car.** Exposure to intense sunlight and heat may cause the batteries to leak, overheat or explode, resulting in fire, burns or other injuries. High temperatures may also cause deformation of the casing. Ensure that there is good ventilation when using the battery charger to charge the batteries.
 - **Do not store the equipment in humid or dusty areas.** Storage in such areas could lead to fire, electrical shock or other damage.
 - **Be careful not to bang the camera or subject it to strong impacts or shocks that could lead to injury or damage the equipment when wearing or holding it by the strap.**
 - **Be careful not to cover the flash with your fingers or clothing when shooting.** The flash may be damaged and emit smoke or noise. In addition, do not touch the surface of the flash after taking several pictures in rapid succession. Either action could result in burns.
 - **Do not operate the flash with dirt, dust or other items stuck to its lens.** The resulting heat build-up could damage the flash.
-

-
- **Ensure that the battery charger or compact power adapter is plugged into a power outlet of the specified rating, not over the specified rating.** The plug of the battery charger or compact power adapter varies according to region.
 - **Do not use the battery charger or compact power adapter if the power cord is damaged or if the plug is not fully inserted into the power outlet.**
 - **Do not allow metal objects (such as pins or keys) or dirt to contact the charger terminals or plug.**
 - **If your camera is used for prolonged periods, the camera body may become warm.** Please take care when operating the camera for an extended period as your hands may experience a burning sensation.
-

Preventing Malfunctions

Avoid Strong Magnetic Fields

Never place the camera in close proximity to electric motors or other equipment generating strong electromagnetic fields. Exposure to strong magnetic fields may cause malfunctions or corrupt image data.

Avoid Condensation Related Problems

Moving the equipment rapidly between hot and cold temperatures may cause condensation (water droplets) to form on its external and internal surfaces. You can avoid this by placing the equipment in an airtight, resealable plastic bag and letting it adjust to temperature changes slowly before removing it from the bag.

If Condensation Forms Inside the Camera

Stop using the camera immediately if you detect condensation. Continued use may damage the equipment. Remove the CF card, batteries or compact power adapter from the camera and wait until the moisture evaporates completely before resuming use.

Extended Storage

When not using the camera for extended periods of time, remove the batteries from the camera or battery charger and store the equipment in a safe place. Storing the camera for extended periods with batteries installed will cause battery leakage and damage the camera.

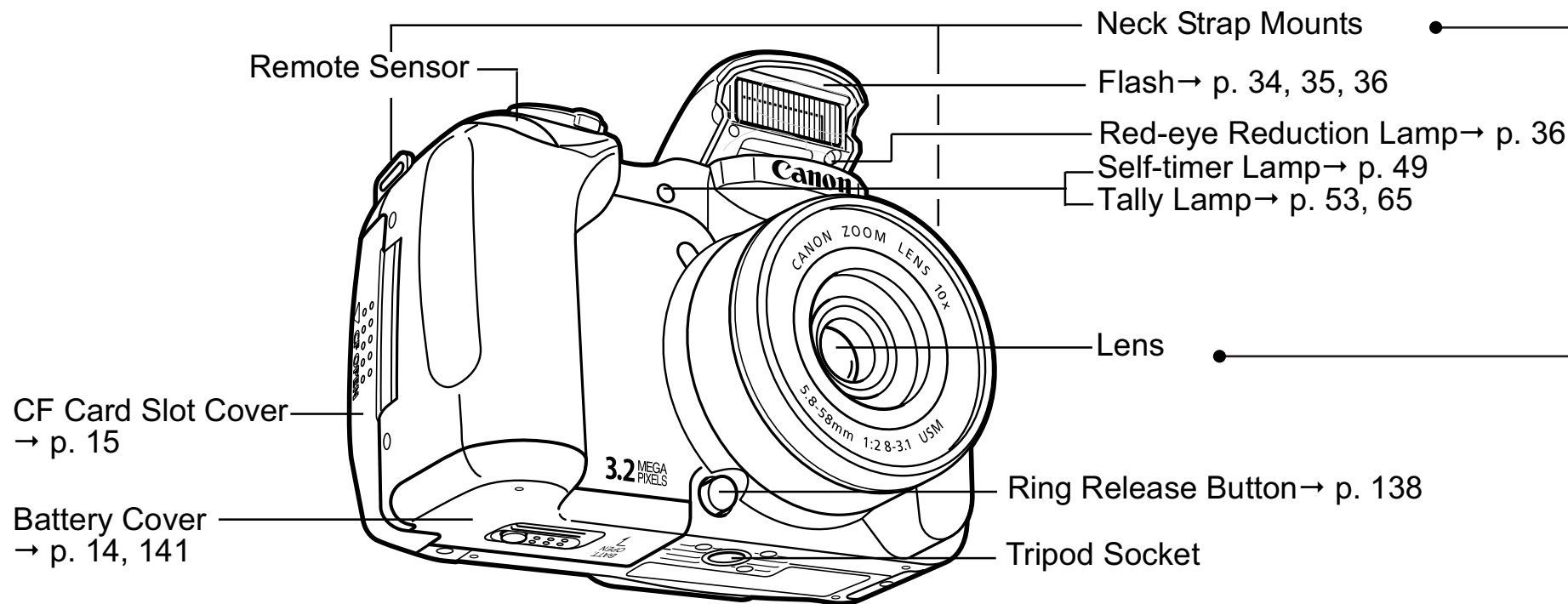

* The following cables are used to connect the camera to a computer or printer.

Computer: Interface Cable IFC-400PCU (supplied with the camera)

Direct Print Compatible Printers (Sold Separately):

● CP Printers: Interface Cable IFC-400PCU (supplied with the camera) or the Direct Interface Cable DIF-100 (supplied with the printer).

● Bubble Jet Printers

• *Bubble Jet Direct* Compatible Printers: Please refer to your Bubble Jet printer user guide.

• *PictBridge* Compliant Printers: Interface Cable IFC-400PCU (supplied with the camera)

● *PictBridge* Compliant Non-Canon Printers: Interface Cable IFC-400PCU (supplied with the camera)

Please refer to the *System Map* or the *Direct Print User Guide* supplied with the camera for direct print compatible printer information.

Attaching the Neck Strap

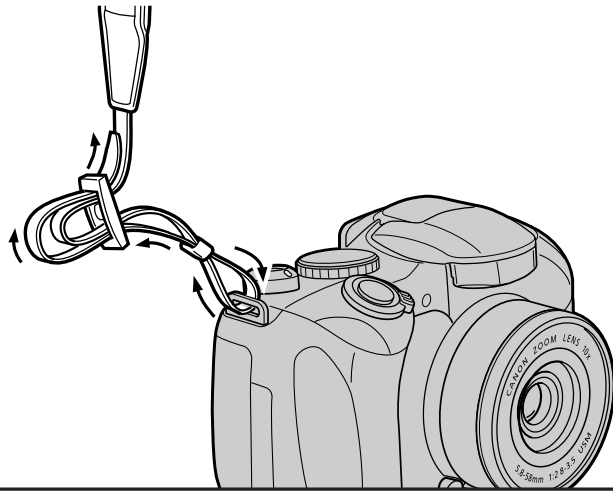

Attach the strap as illustrated. Check that the strap does not come loose from the strap mount when pulled. Perform the same steps on the other side of the camera.



Avoid waving the camera about or catching it on other items when suspending it from the strap.

Attaching the Lens Cap

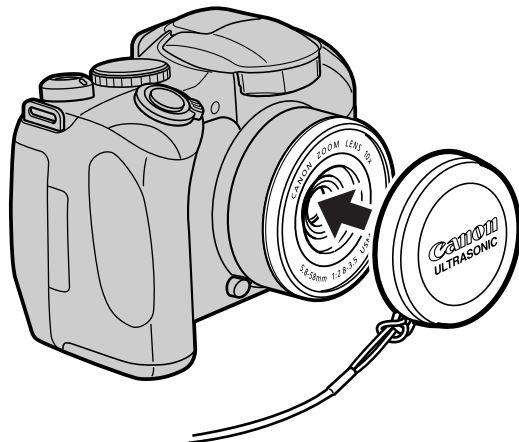

Fit the lens cap over the lens casing so that it covers the entire lens. Always replace the lens cap after use.



- ◆ Attach the lens cap cord to the strap.
- ◆ Remove the lens cap before turning on the camera's power.

Controls

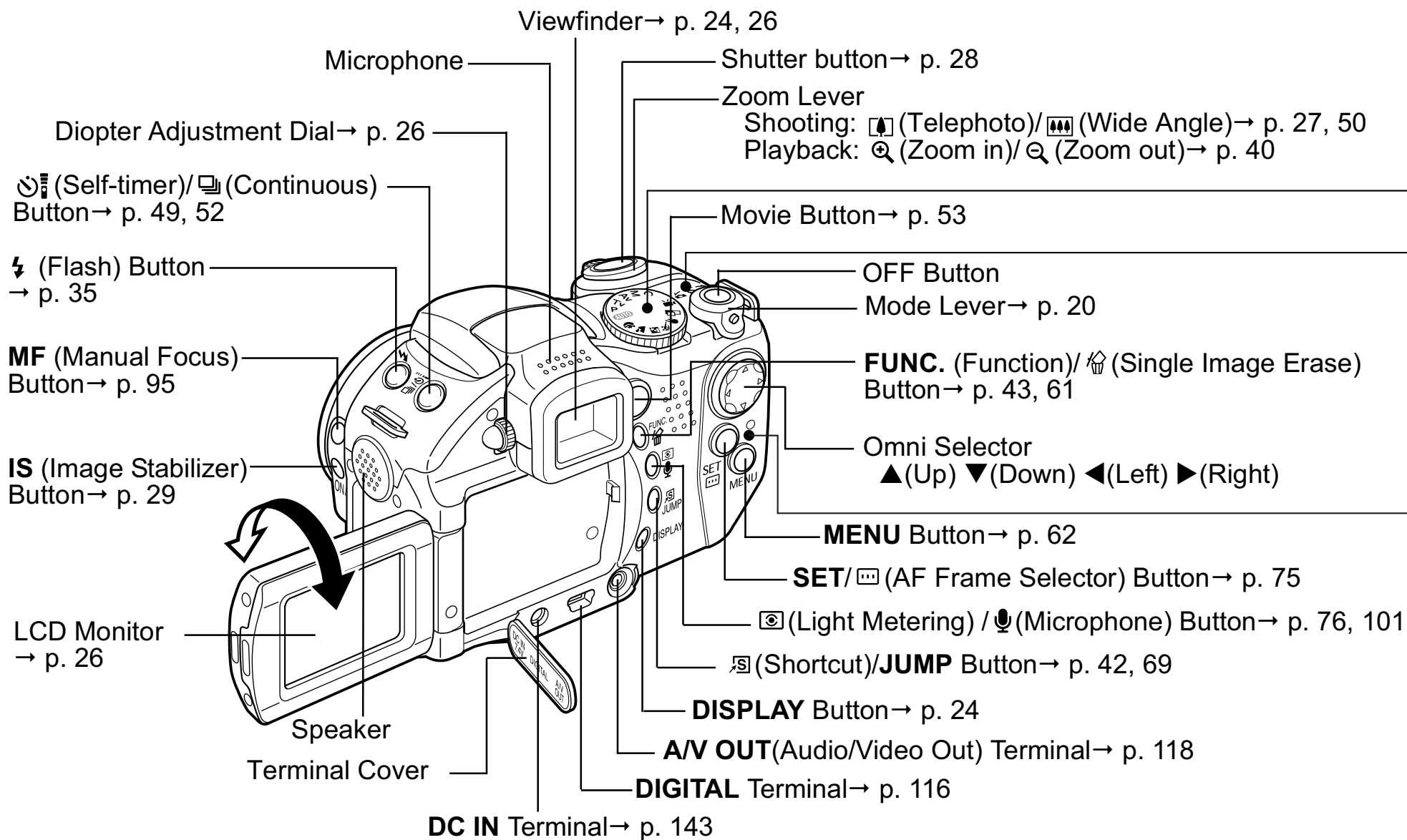

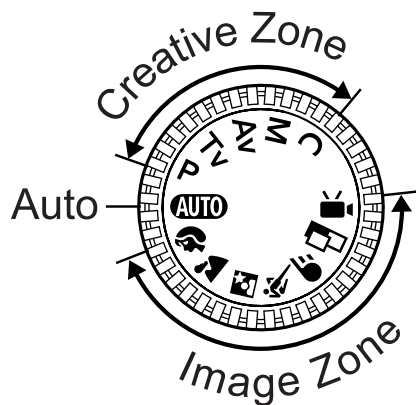

Mode Dial

Use the mode dial to switch between the Shooting modes.

- **AUTO**: Auto → p. 27
The camera automatically selects settings.
- **Image Zone** → p. 45
The camera automatically selects settings according to the image composition type.
 - : Portrait
 - : Landscape
 - : Night Scene
 - : Fast Shutter

- : Slow Shutter
- : Stitch Assist → p. 47
- : Movie → p. 53

- **Creative Zone** → p. 71
The user selects exposure, aperture or other settings to achieve special effects.
 - **P** : Program AE
 - **Tv** : Shutter Speed-priority AE
 - **Av** : Aperture-priority AE
 - **M** : Manual Exposure
 - **C** : Custom

The indicator lights or blinks when the shutter button is pressed or the following operations are underway.

- **Power/Mode Indicator**
 - Orange: Shooting mode
 - Green: Playback mode/Printer connection
 - Yellow: Computer connection
- **Indicator**
 - Blinking Red: Recording to CF card/Reading CF card/Erasing from CF card/Transmitting data (during a computer connection)

Installing the Batteries/CF Card

Install the batteries and the CF card to get ready for shooting.

Please use four AA-size alkaline batteries or separately sold nickel metal hydride (NiMH) batteries.

-  When the indicator blinks, the camera is writing, reading, erasing or transmitting an image to or from the card. Do not perform the following or image data may be lost or corrupted:
- Do not shake the camera.
 - Do not turn off the power or open the CF card slot cover or the battery cover.



- ◆ The use of the separately sold Compact Power Adapter CA-PS700 is recommended to power the camera during long usage sessions (p. 143).
- ◆ The separately sold battery charger kit lets you use rechargeable NiMH batteries to power the camera (p. 140).
- ◆ See *Battery Performance* (p. 150).
- ◆ For information about the Battery and Charger Kit and AA-size rechargeable NiMH batteries, see the *System Map* (separate from this guide).

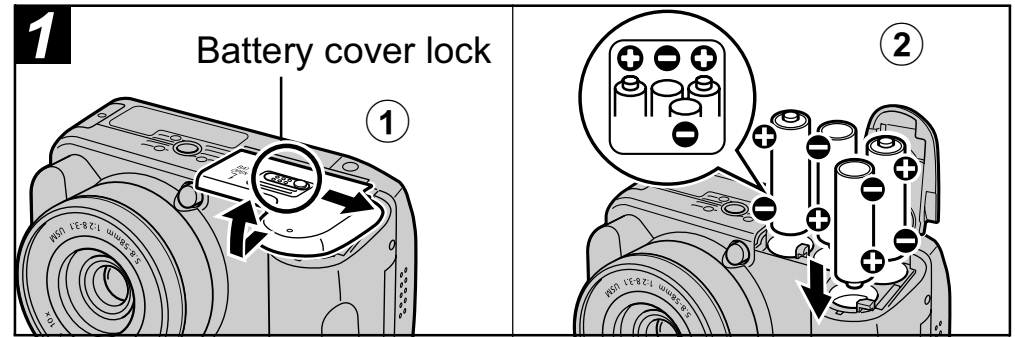

- ① Be sure that the camera power is off (p. 19). Slide the battery cover lock in the direction of the arrow and open the cover.**
- ② Insert the batteries as shown.**
 - You can check the orientation the batteries should go in on the seal inside the battery compartment.
- ③ Close the battery cover.**

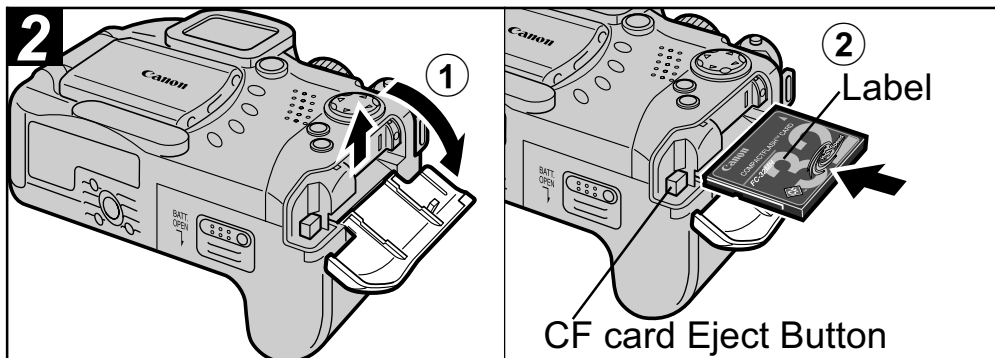

- ① Slide the CF card slot cover in the direction of the arrow, and open it.
- ② Insert the CF card with the label facing up, then close the CF card slot cover.
 - Push the card in until the CF card eject button fully extends. To remove the CF card, push the CF card eject button and pull the card out.



- See *CF Cards and Estimated Capacities (Recordable Images)* (p. 151).
- You are recommended to use CF cards that have been formatted in your camera (p. 18). The card supplied with the camera may be used without further formatting.

Proper Battery Handling

- Use AA-size alkaline or Canon AA-size NiMH batteries (sold separately) only. For information on handling the AA-size rechargeable NiMH batteries, see *Using the Power Kits (Sold Separately)* (p. 140).
- **Since the performance of alkaline batteries may differ according to brand, the operating time of the batteries you purchase may not be as long as the batteries that came with the camera.**
- Camera operating time may shorten at low temperatures when alkaline batteries are used. Also due to their specifications, alkaline batteries may expire faster than NiMH batteries. If you are using the camera in cold areas or for a long time, we recommend using Canon's AA-size NiMH Battery Kit (a four-piece set).

- While it is possible to use AA-size nickel-cadmium batteries, performance is unreliable and their use is not recommended.
- **Never mix unused and partially used batteries. Always load four fresh (or fully recharged) batteries at the same time.**
- **Be careful to load the batteries with their positive (+) and negative (-) ends in the right direction.**
- **Never mix batteries of different types or from different manufacturers. All four batteries should be identical.**
- Before inserting the batteries, wipe the battery terminals well with a dry cloth. Oil from one's skin or other dirt may cause a considerable reduction in the number of recordable images or reduce usage time.
- Battery performance deteriorates at low temperatures (especially with alkaline batteries). If you are using the camera in cold areas and batteries are running down faster than they should, you may be able to restore performance by placing batteries in an inner pocket to warm them up prior to use. But be careful that you don't put the batteries into a pocket together with a metal key chain or other metallic objects, as these objects may cause batteries to short-circuit.

- If you do not plan to use the camera for a long time, remove the batteries from the camera and store them in a safe place. Batteries may leak and damage the camera if left installed during prolonged periods of non-use.



WARNING

Never use damaged batteries or batteries whose outer seal is completely or partially missing or peeled off, as there is risk that such batteries may leak, overheat, or burst. Always check the seals on store-bought batteries before loading them, as some batteries may come with defective seals. Do not use batteries with defective seals.

Never use batteries that look like this.

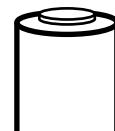

Batteries with all or part of the seal (electrical insulation sheath) peeled off.

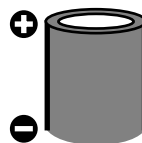

The positive electrode (plus terminal) is flat.

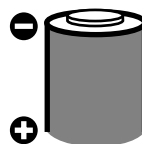

The negative terminal is correctly formed (protruding from the metal base), but the seal does not extend up over the edge of the metal base.

Battery Status Indications

The following icons or messages indicate the battery status on the LCD monitor (or viewfinder).

	Batteries are beginning to run low. Replace or recharge the batteries if you wish to continue using the camera.
Change the batteries	Batteries are fully depleted and the camera can no longer operate. You should replace the batteries immediately.

CF Card Handling Precautions

- CF cards are high-precision electronic devices. Do not bend, force, or subject them to shocks or vibration.
- Do not attempt to disassemble or alter a CF card.
- Moving a CF card rapidly between temperature extremes may cause condensation to form in the card, leading to potential malfunctions. To avoid condensation formation, place the CF card in a sealed plastic bag before moving it into a different temperature zone and allow it to adjust slowly to the new temperature. If condensation forms on the CF card, put it aside until the water droplets have evaporated completely.
- Place the CF card in the supplied case for storage.

- Do not use or store CF cards in the following types of locations.
 - Locations subject to dust or sand
 - Locations subject to high humidity and high temperatures

Microdrives are a recording medium with a hard disk. Their merits are a large capacity and a low price per megabyte of capacity. However, they can be more susceptible to vibrations and shocks than CF cards, which use durable flash memories. Please be careful, therefore, not to subject the camera to vibrations or shocks when using a microdrive, especially while recording or playing back.

Formatting a CF Card

You should always format a new CF card or one from which you wish to erase all images and other data.

 Please note that formatting (initializing) a CF card erases all data, including protected images and other file types. Please check the contents of the CF card before formatting it.



- ◆ If the camera does not work properly, the inserted CF card may be malfunctioning. Reformatting the CF card may solve the problem.
- ◆ When a non-Canon brand CF card is malfunctioning, reformatting it may solve the problem.
- ◆ CF cards formatted in another camera, computer or peripheral device may not operate correctly. When that happens, reformat the CF card with this camera.
- ◆ The capacity of the CF card displayed after formatting will be less than the rated capacity of the CF card. This is not a malfunction of the CF card or camera.

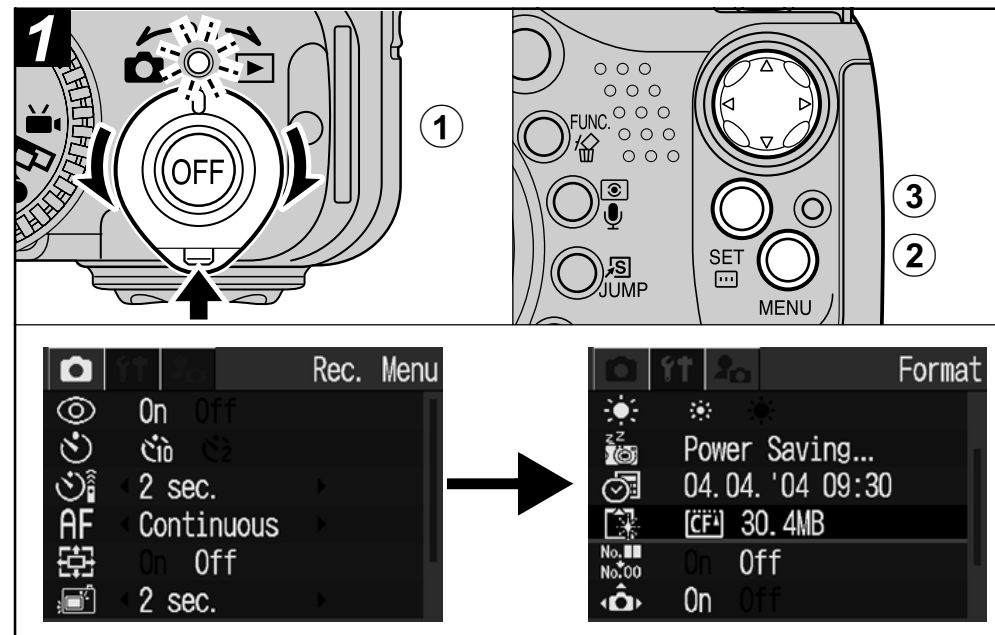

- ① Turn the power on (p. 19).
- ② Press the **MENU** button, and then the **▶** arrow on the omni selector.
The [] (Set up)] menu appears.
- ③ Select [**Format**] using the **▲** or **▼** arrow on the omni selector, then press the **SET** button.

Turning the Power On/Off

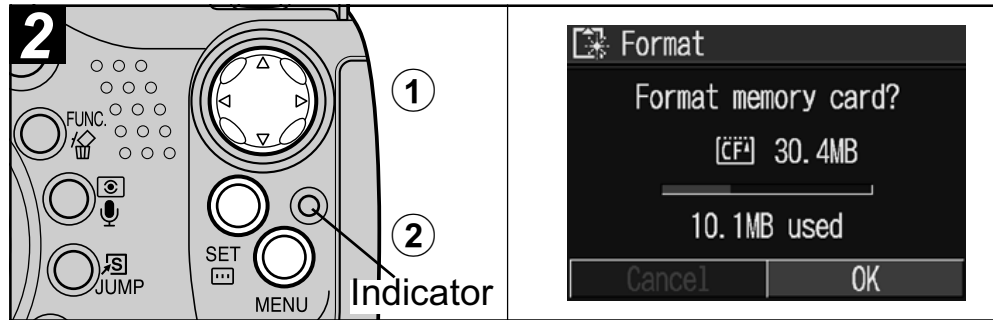

① Select [OK] using the ◀ or ▶ arrow on the omni selector, then press the SET button.

The indicator blinks red and formatting starts. Wait until the indicator goes off.

- To cancel instead of erasing, select [Cancel] and press the **SET** button.

② Press the MENU button.

The power/mode indicator remains lit while the power of the camera is on. The power/mode indicator indicates the state of the camera as follows.

Orange: Shooting mode

Green: Playback mode/Printer connection mode*

Yellow: Computer connection mode*

Off: The power of the camera is off.

* For printer connection mode, see the *Direct Print User Guide*. For computer connection mode, see the *Canon Digital Camera Software Starter Guide Disk*.



- ◆ You will hear a start-up sound and see the start-up image when the power comes on (p. 111).
- ◆ The start-up image does not appear when the viewfinder display is on in Shooting mode or the A/V OUT terminal is connected to a TV.
- ◆ Be careful not to touch the lens when shooting. Please also refrain from forcing the lens with fingers or other objects. It could lead to malfunctions or damage the camera. If this occurs, turn the camera off and back on.

Turning on the camera without the start-up sound and image

Press and hold the  button, then turn on the power. You can also turn the power on with the LCD monitor closed.

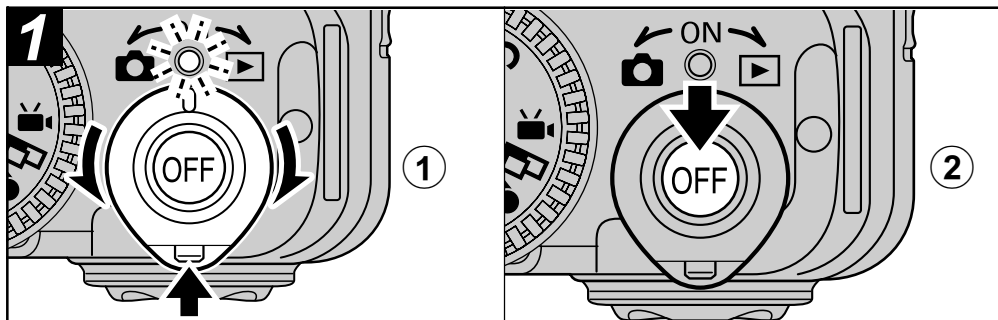

- ① Turn the mode lever to (Shooting) or (Playback) while pressing the release button.

The power/mode indicator lights orange or green.

- ② Press the OFF button to turn the power off.

Switching Between Shooting and Playback

You can quickly switch between Shooting mode and Playback mode. This is convenient when you wish to shoot again after checking or deleting an image immediately after it is shot.

Shooting Mode ➡ Playback Mode

Turn the mode lever to (Playback) while pressing the release button (p. 39).

- The camera switches to Playback mode, but the lens does not retract (the lens will retract if you turn the mode lever to (Playback) once more)

Playback Mode ➡ Shooting Mode

Remove the lens cap and press the shutter button halfway.

You can also turn the mode lever to (Shooting) while pressing the release button (p. 27).

Setting the Date/Time

The first time the camera power is turned on or whenever the lithium battery charge is low, start from Step **3**.



- ◆ Setting the date and time settings does not cause the date/time stamp to appear on images. For printing images with the date on them, refer to the *Direct Print User Guide* or *Canon Digital Camera Software Starter Guide Disk*.
- ◆ See *Replacing the Date Battery* (p. 144).

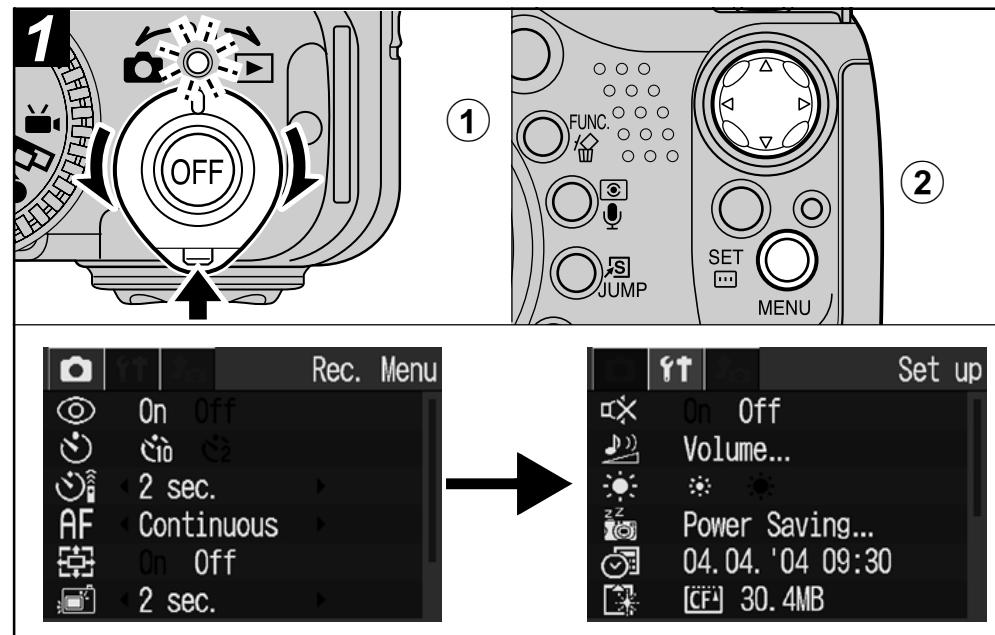

- ① Turn the power on (p. 19).
- ② Press the MENU button, and then the ► arrow on the omni selector.
The [] (Set up) menu appears.

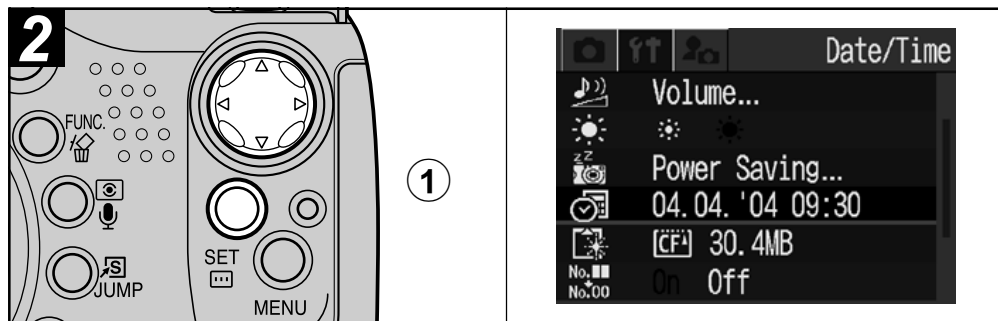

① Select [Date/Time] using the ▲ or ▼ arrow on the omni selector, then press the SET button.

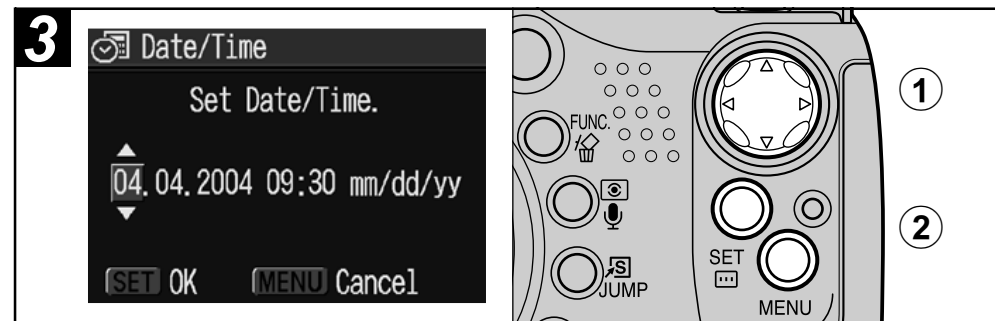

① Set the date and time.

- Select the item you wish to set using ◀ or ▶ and set its value using the ▲ or ▼ arrow on the omni selector.

② Check that the date and time display correctly, press the SET button and press the MENU button.

- The date can be set up to the year 2037.

Setting the Language

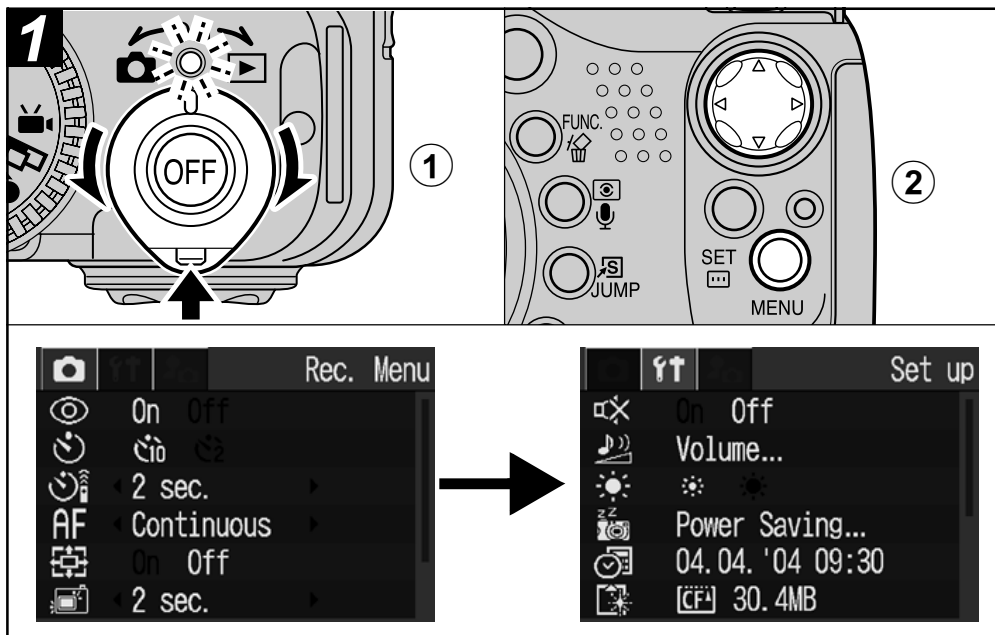

- ① Turn the power on (p. 19).
- ② Press the **MENU** button, and then the **▶** arrow on the omni selector.

The [**⏏**] (Set up) menu appears.

- In Playback mode, you can change the language by holding the **SET** button while you press the **JUMP** button. This function cannot be used during movie playback or during a printer connection.

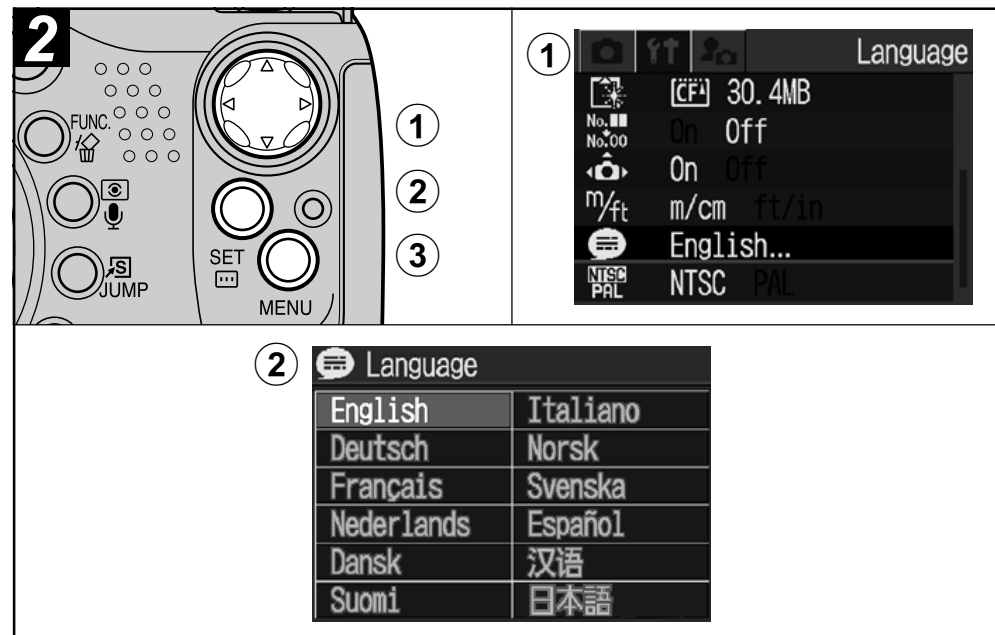

- ① Select [**Language**] using the **▲** or **▼** arrow on the omni selector, then press the **SET** button.
- ② Select a language using the **▲**, **▼**, **◀** or **▶** arrow on the omni selector, then press the **SET** button.
- ③ Press the **MENU** button.

Using the Viewfinder and the LCD Monitor

Pressing the **DISPLAY** button switches the LCD monitor display mode. Also, closing the LCD monitor causes the viewfinder to display.

Shooting Mode

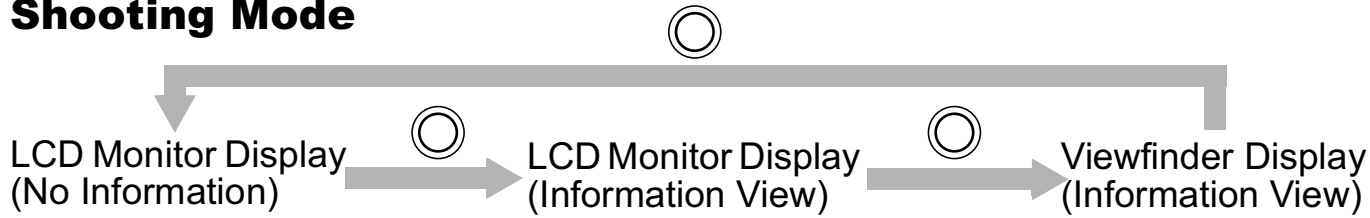

⊙ : Press the **DISPLAY** button

The combined optical zoom and digital zoom factor displays.



Spot Metering Frame
AF Frame

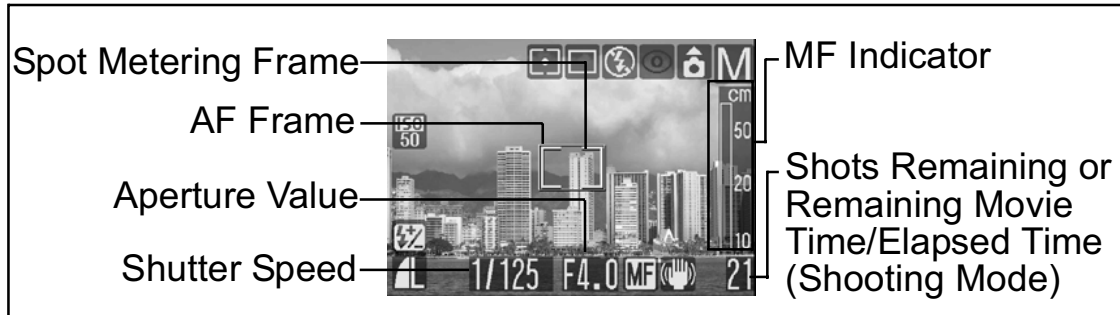

About the AF Frame
Green: Focusing Complete
Yellow: Focusing Difficulty
*The AF frame does not appear when it is set to Auto or during Reverse Display.

Playback Mode



→ Single Image Playback
→ Index Playback

Histogram (p. 154)

Display Contents

Function	Icon	Shooting Mode		Playback Mode		Reference Page
		Information View	No Information	Detailed Display	Standard Display	
Shooting Modes		○	-*1	○*2	-	p. 45, 71
Exposure Compensation	-2 - +2	○	-	○*3	-	p. 78
AE Lock/FE Lock		○	○	-	-	p. 86, 87
Light Metering Mode		○	-	○	-	p. 76
White Balance (WB)*4		○	-	○	-	p. 79
Drive Mode		○	-	-	-	p. 49, 52
ISO Speed		○	-	○	-	p. 81
Photo Effect		○	-	○	-	p. 82
Bracket		○	-	-	-	p. 84
Flash		○	-	-	-	p. 34
Red-eye Reduction		○	-	-	-	p. 36
Flash Exposure Compensation		○	-	○*3	-	p. 89

Flash Output		○	-	-	-	p. 89
Compression		○	-	○	○	p. 32
Resolution	L M1 M2 S	○	-	○	○	p. 32
Resolution (Movies)		○	-	○	-	p. 32
Frame Rate (Movies)		○	-	○	-	p. 32
Digital Zoom*5	10x 13x 16x 20x 25x 32x	○	○	-	-	p. 50
Low Battery		○	○	○	○	p. 17
Auto Rotate		○	-	-	-	p. 108
Camera Shake Warning		○	○	-	-	p. 26
Manual Focus		○	○	-	-	p. 95
Image Stabilizer		○	-	-	-	p. 29
Movie Recording	● (red)	○	○	-	-	p. 53
Sound Memo (WAVE file)		-	-	○	○	p. 101
Movie		-	-	○	○	p. 57
Protection Status		-	-	○	○	p. 106

*1 (Movie) appears even in No Information display mode.

*2 **C** (Custom) does not appear.

*3 The value for each content also appears.

*4 The icon does not display in Playback mode.

*5 Zoom powers reflect the combined optical and digital zoom effects. "10x" is the telephoto-end setting of the optical zoom.



- ◆ Even in the no information display mode, shooting information appears for approximately 6 seconds (shooting information may not appear depending on the camera settings at that time).
- ◆ The camera shake warning icon  will appear on the LCD monitor (or viewfinder) in low light conditions while the camera is preparing to shoot. When this icon appears, use one of the following shooting methods.
 - Set the flash to On or Auto
 - Set the image stabilizer function to On (p. 29)
 - Fix the camera to a tripod
- ◆ Please note that image information recorded by this camera may not display correctly on other cameras and image information recorded by other cameras may not display correctly on this camera.

Overexposure Warning

Overexposed portions of the image blink. The overexposure warning appears at the following times.

- ◆ When reviewing an image right after it is shot in the LCD monitor (information view) or in the viewfinder
- ◆ In the detailed display mode of the Playback mode

Using the LCD Monitor

The LCD monitor can be opened to the following range of positions.

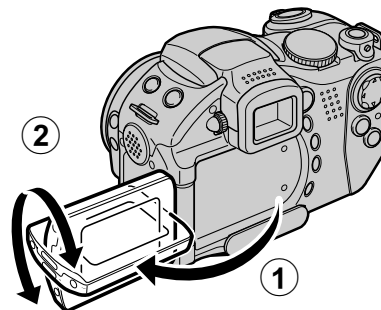

Opened from right to left 180 degrees. Tilted forward 180 degrees toward the lens or backward 90 degrees.

- When the LCD monitor is opened left 180 degrees and tilted 180 degrees toward the lens, the displayed image is automatically flipped and reversed (the Reverse Display function) so that it appears correctly from in front of the lens.

Fold the LCD monitor back against the camera body until it clicks into place.

- If it is not fully closed, the image will appear reversed. Always keep the LCD monitor closed to protect it when the camera is not in use.

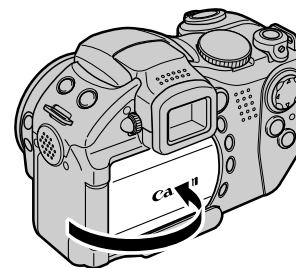

Using the Viewfinder

If the surroundings are too bright (for example, when you are shooting outdoors) and images on the LCD monitor are not clear, use the viewfinder for shooting. Adjust the viewfinder focus with the diopter adjustment dial (p. 12) so the displayed information (p. 24) appears clearly.

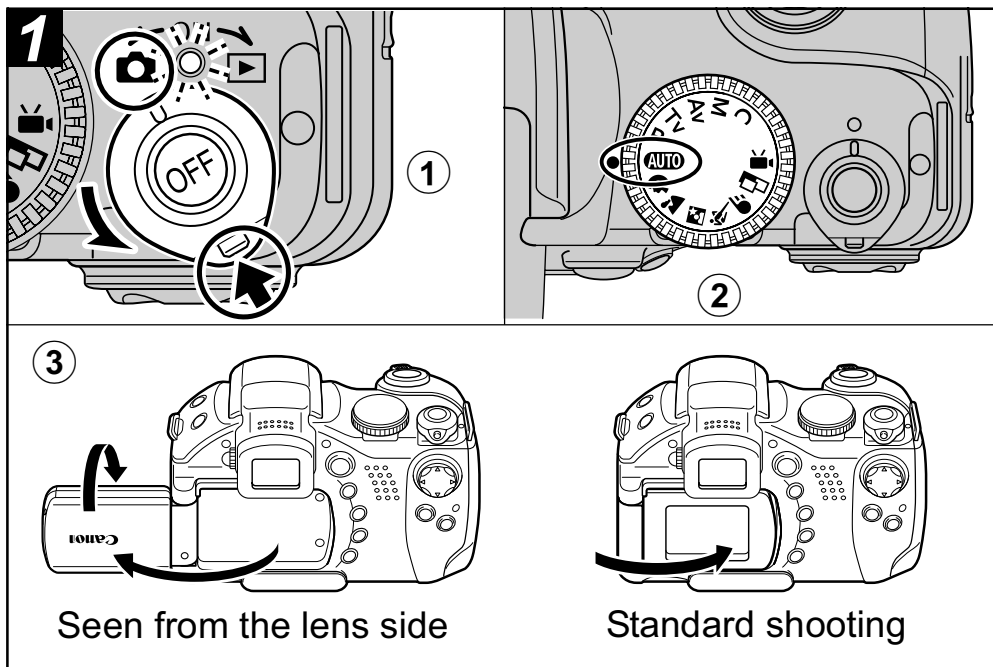

① Turn the mode lever to (Shooting).

② Set the mode dial to **AUTO**.

③ If you are using the LCD monitor, open it.

- The LCD monitor can also be rotated. When the LCD monitor is tilted 180 degrees, the displayed image is automatically flipped and reversed (the Reverse Display function) so that it appears correctly from in front of the lens (you can disable the Reverse Display function (p. 65)).

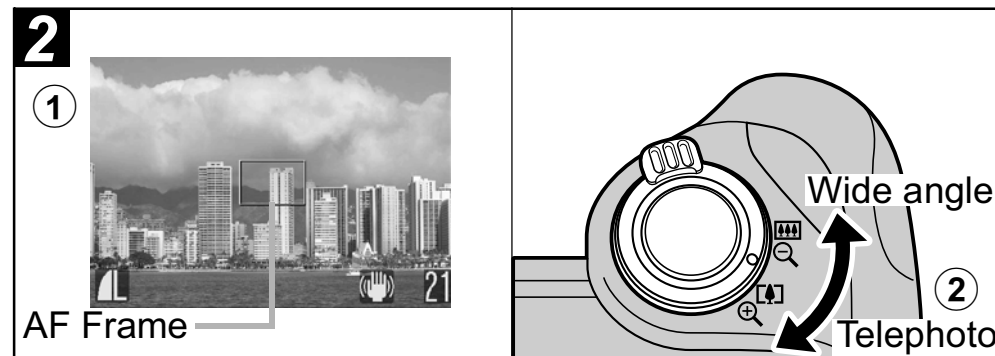

① Aim the camera at the subject.

② Use the zoom to achieve the desired composition in the LCD monitor (or viewfinder).

- Turning the zoom lever toward magnifies the subject (telephoto). Turning the zoom lever toward decreases the size of the subject (wide angle). The speed at which the magnification change is determined by the way the zoom lever is turned. Turning the zoom lever in one swift movement completely to the right/left enables fast zooming. For slow zooming, slowly turn the zoom lever halfway.
- The angle of view can be adjusted within the 38 to 380 mm range, in 35mm film equivalent.

- The combined use of the digital zoom and optical zoom enables magnified shooting up to approx. 32x (p. 50). The digital zoom cannot be used with some shooting modes (p. 166). Images become coarser the more they are digitally zoomed.

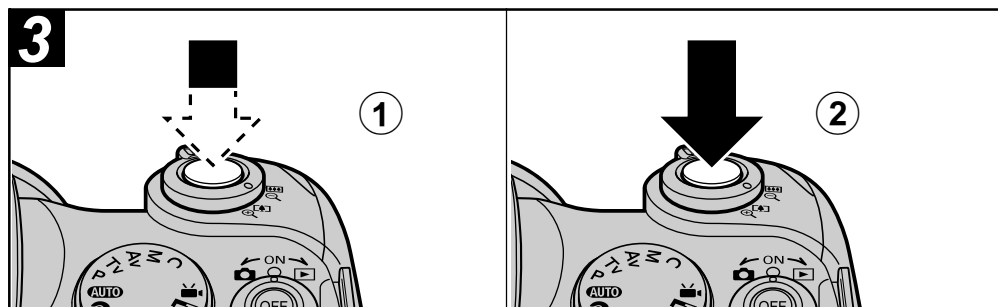

① Lightly press the shutter button (pressing halfway) to focus.

Two beeps will sound when the camera has finished focusing, and the AF frame appears green.

- The AF frame will light yellow and the beep will sound one time if the subject is difficult to focus on. When the AF frame is set to Auto, it will not appear.
- The shutter speed and aperture value are automatically determined and show on the LCD monitor (or viewfinder). The exposure compensation (p. 78) and focus (p. 95) are also automatically set.

② Press the shutter button all the way.

You will hear the shutter sound when the shot is complete. Do not move the camera until you hear this sound. The picture appears for two seconds.



- ◆ See page 166 for settings that can be changed in this mode.
- ◆ The LCD monitor and viewfinder have a field of vision of approximately 100% of the actual shooting image.
- ◆ Images are first saved into the camera's internal memory before being recorded onto the CF card, allowing the next images to be taken immediately as long as sufficient space is available in the internal memory.
- ◆ The indicator blinks red while data is recorded onto the CF card.
- ◆ The beep and shutter sound can be set to On/Off using the menu (p. 66).
- ◆ If the shutter sound is set to [Off] and the mute option is set to [Off], the camera will beep once when the shutter button is pressed all the way.
- ◆ Shots cannot be taken while the flash is charging.

- ◆ You can change the length of time images show on the LCD monitor after shooting, or set it so they do not show at all (p. 31).

Image Stabilizer Function

The image stabilizer function allows you to minimize the camera shake effect (blurred images) when you shoot distant subjects that have been magnified or when you shoot in dark conditions. This function's default setting is [On].

- Pressing the **IS** button switches the function On and Off. When it is set to On,  appears.
- Holding the **IS** button allows you to select the image stabilizer mode. The following icons appear. Select a setting using the ◀ or ▶ arrow on the omni selector and press the **IS** button.

 (Standard): Standard Shooting

 (With teleconverter lens):

Select when the separately sold teleconverter lens (p. 137) is mounted.

 (With wide angle lens):

Select when the separately sold wide angle lens (p. 137) is mounted.



- Camera shake may not be fully corrected when shooting with slow shutter speeds with such shooting scenes as evening shots. In this case, affix the camera to a tripod.
- If camera shake is too strong, it may not be fully corrected.

Reviewing an Image Right after Shooting

Mode Dial



After a photo is taken, the image displays for two seconds (to change this setting, see page 31). There are two ways to display the image for longer:

- **Keeping the shutter button pressed**
- **Pressing the SET button while the image is displayed**

Press the shutter button halfway again to stop displaying it and shoot an image.



You can perform the following while images are displayed.

- ◆ Display images in detailed display mode (p. 26)
- ◆ Magnify images (p. 40)
- ◆ Erase images individually (p. 43)
- ◆ Attach Sound Memos (p. 101)

Changing the Image Display Duration

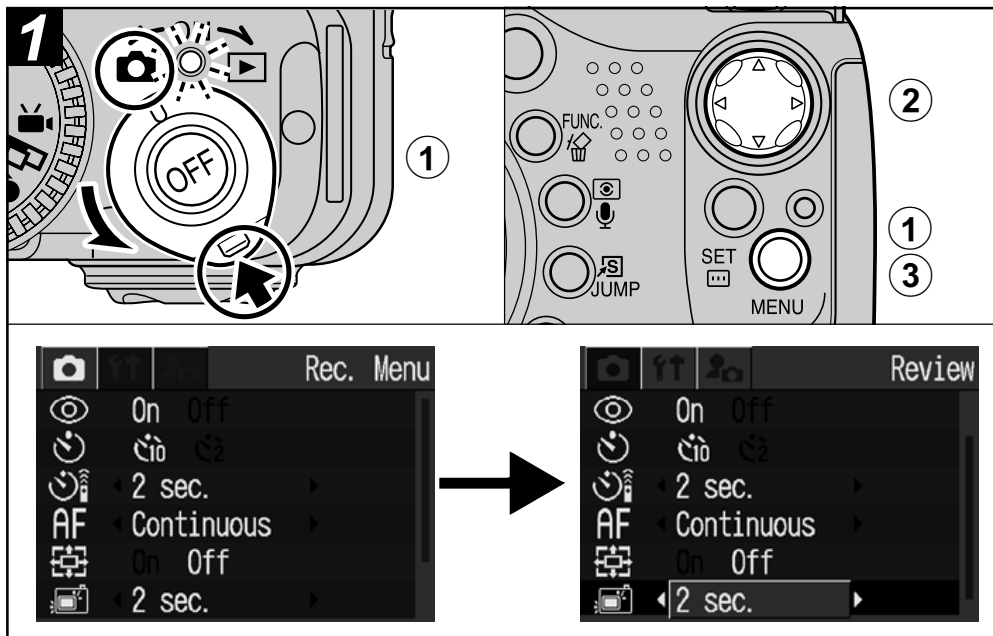

- ① Turn the power on (p. 19), and press the **MENU** button.

The [(Rec.)] menu appears.

- ② Select [Review] using the ▲ or ▼ arrow on the omni selector and select a duration setting using the ◀ or ▶ arrow on the omni selector.

Off: Images do not display

2 to 10 sec.: Images appear for the time selected even if the shutter button is released.

- ③ Press the **MENU** button.

- You can continue to display the image as long as the shutter button is fully held pressed regardless of the Review setting.
- Another picture can be taken even while the last is displayed.

Changing the Resolution and Compression

Mode Dial



You can change the resolution, compression (still images) and frame rate (movies, p. 56) settings to suit the purpose of the image you are about to shoot.

Still Images

Resolution		Purpose
Display	Pixels	
L (Large)	2048 x 1536	<ul style="list-style-type: none"> ● Print A4 size* 210 x 297 mm (8.3 x 11.7 in.) prints ● Print letter size* 216 x 279 mm (8.5 x 11 in.) prints
M1 (Medium 1)	1600 x 1200	<ul style="list-style-type: none"> ● Print postcard size 148 x 100 mm (6 x 4 in.) prints ● Print L size 119 x 89 mm (4.7 x 3.5 in.) prints
M2 (Medium 2)	1024 x 768	<ul style="list-style-type: none"> ● Print credit card size 86 x 54 mm (3.4 x 2.1 in.) prints
S (Small)	640 x 480	<ul style="list-style-type: none"> ● Send images as e-mail attachments ● Shoot more images

* Paper sizes vary according to region.

Compression			Purpose
Superfine	High Quality ↑ Normal ↓	High Quality	Shoot higher quality images
Fine		Normal	Shoot normal quality images
Normal		Normal	Shoot more images

Movies

Resolution	Image Quality	Recording Time	Purpose
640 x 480 pixels (Fine)*	High ↑ Normal ↓	Short ↑ Long ↓	Shoot higher quality movies
640 x 480 pixels*			Shoot normal quality movies
320 x 240 pixels*			Shoot longer movies

* The compression rate for is Fine. The compression rate for and is Normal.

Frame Rate	Quality	Recording Time	Purpose
Approx. 30 frames/sec.	Full-motion	Short	Quality-priority shooting
Approx. 15 frames/sec.	Normal	Long	Time-priority shooting

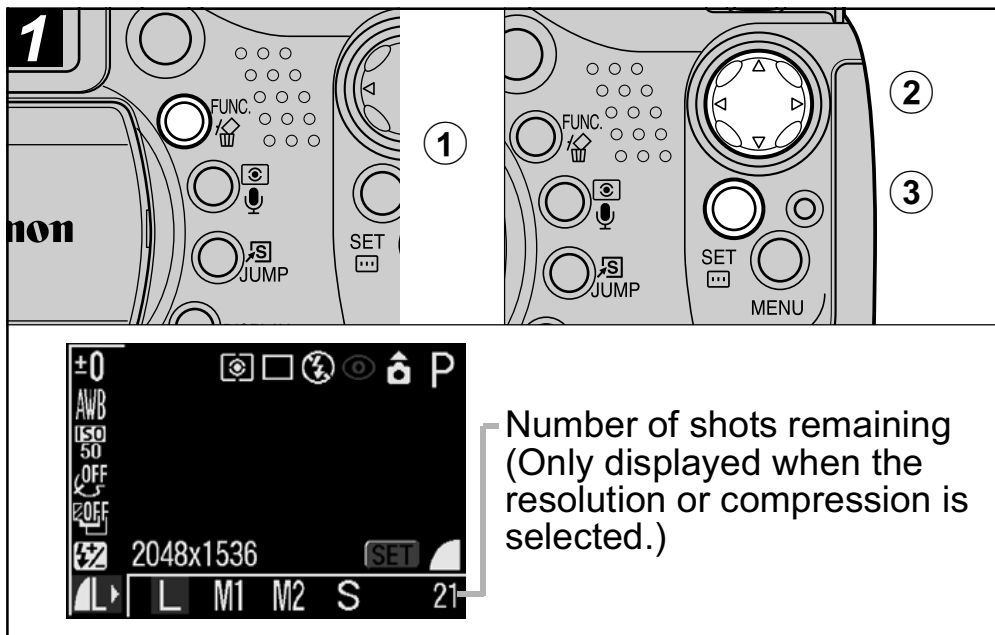

- ① Press the FUNC. button.
- ② Select * (2048 x 1536) using the ▲ or ▼ arrow on the omni selector.
* The current setting is displayed.
- ③ Select the resolution you wish to set using the ◀ or ▶ arrow on the omni selector, then press the SET button.

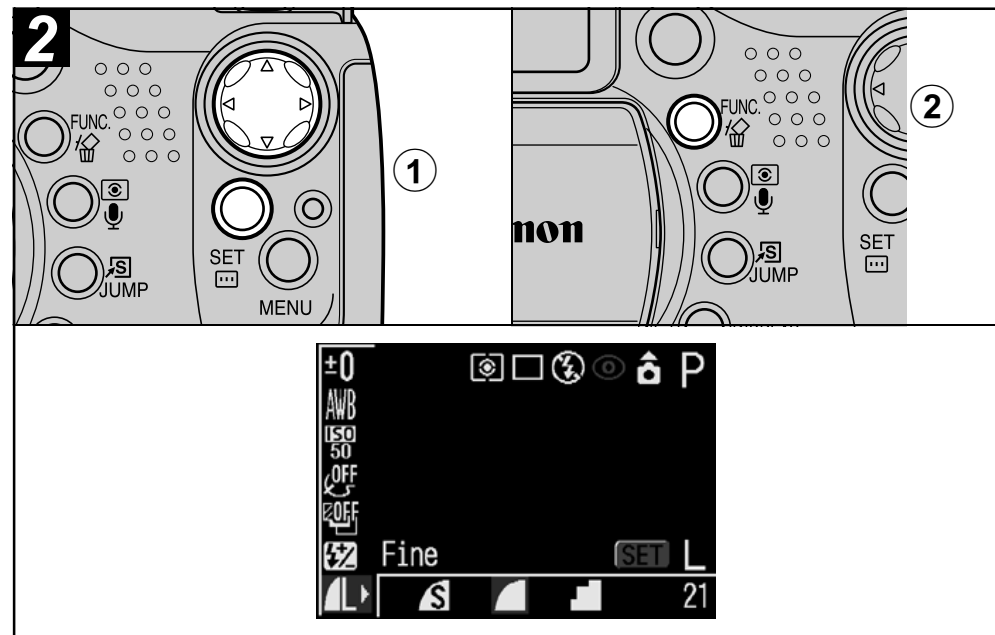

- ① Select the compression you wish to set using the ◀ or ▶ arrow on the omni selector, then press the SET button.
 - You can shoot the image right after selecting settings by pressing the shutter button. This screen will appear again, once the image is shot.
 - In the case of a movie clip, the remaining shooting time (in seconds) appears.
 - See *Image File Sizes (Estimated)* (p. 152).

⚡ Using the Built-in Flash

Mode Dial



Use the flash according to the guidelines below.

The flash operates as shown below when the Flash Pop-up option (p. 64) is set to [Auto].

	Auto with red-eye reduction	The flash fires automatically as required by the lighting level, and the red-eye reduction lamp fires each time the main flash fires.
	Auto	The flash fires automatically as required by the lighting level.
	Flash on with red-eye reduction	The red-eye reduction lamp and the flash always fire.
	Flash on	The flash always fires.
	Flash off	The flash does not fire.

It may take longer for the camera to autofocus right after the flash pops up.

- Types of CF cards and number of shots remaining (p. 151).

② Press the **FUNC.** button and shoot the image.

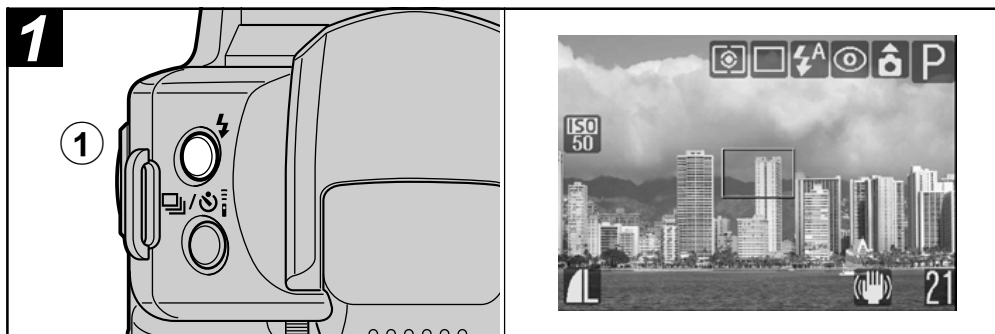

① Press the button to switch between flash modes and shoot the image.

The selected flash mode appears on the LCD monitor (or viewfinder).

- You can switch between settings by pressing the  button. The flash setting may not switch with certain shooting modes.

When the red-eye reduction function is on (p. 36)

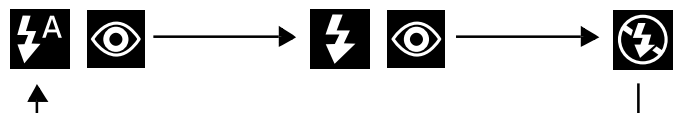

When the red-eye reduction function is off

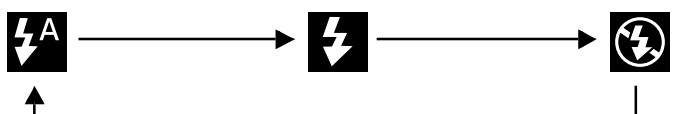



- Be sure to close the flash after use.

When the Flash Pop-up Function is Set to [Off]

Mode Dial

P Tv Av M

You can manually set the flash when Flash Pop-up is set to [Off].

Flash is open ()	The flash always fires.
Flash is closed ()	The flash does not fire.

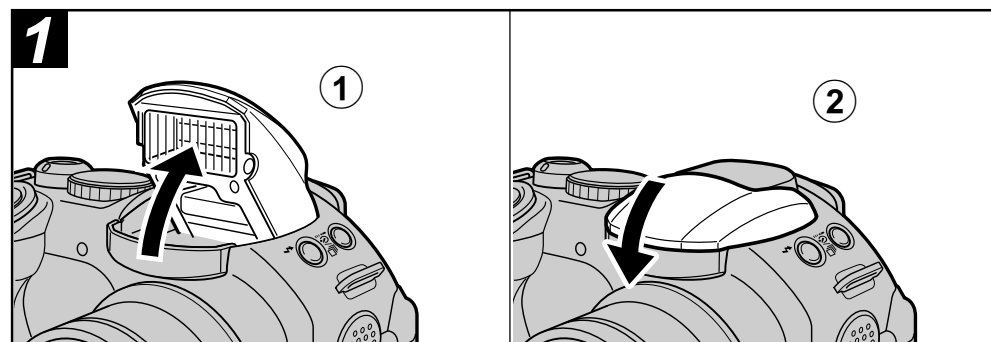

- ① Pop up the flash by pressing the  button and shoot the image.
- ② When you are not using the flash, press the flash down until it clicks.

Setting the Red-eye Reduction Function

Mode Dial

AUTO P Tv Av M

The red-eye reduction lamp fires when the flash is used in dark areas. This reduces light reflecting back from the eyes and making them appear red.

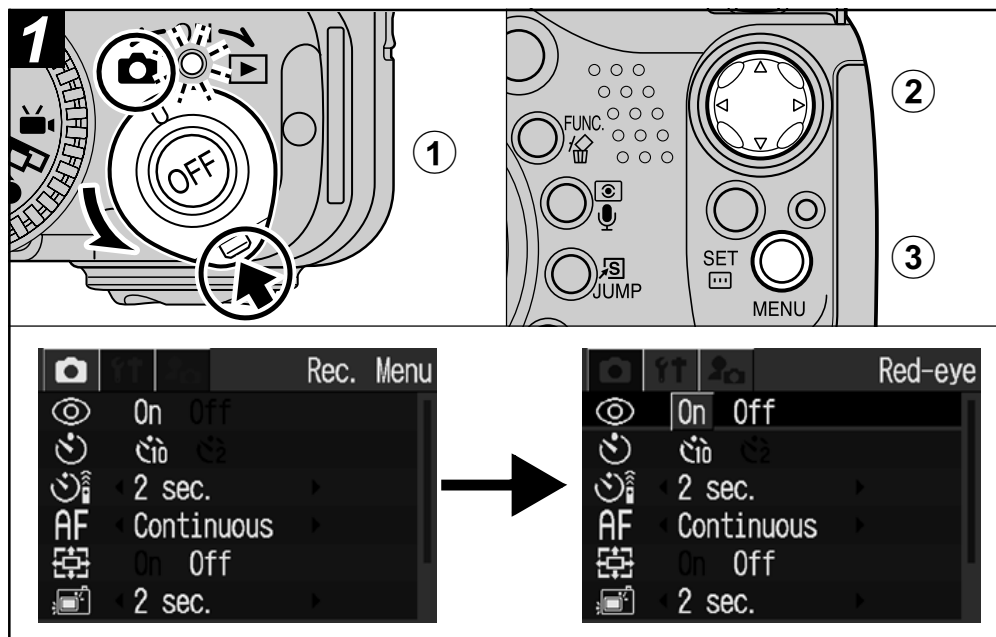

- 1 Power the camera in (Shooting) mode (p. 19) and press the MENU button.

The [] (Rec.) menu appears.

- 2 Select [Red-eye] using the or arrow on the omni selector.

- 3 Select [On] using the or arrow on the omni selector and press the MENU button.

- appears on the LCD monitor (or viewfinder) if it is set to Information View display.
- When shooting with the red-eye reduction function, the subjects must look right at the red-eye reduction lamp for this mode to be effective. Try asking them to look directly at the lamp. Even better results can be obtained by shooting with the lens set to a wide angle, increasing the lighting in indoor settings or approaching closer to the subject.

Setting the Slow Synchro

Mode Dial

P Av

You can shoot images using the flash with a slow shutter speed. This helps brighten up dark backgrounds when shooting night scenes or with indoors lighting conditions.

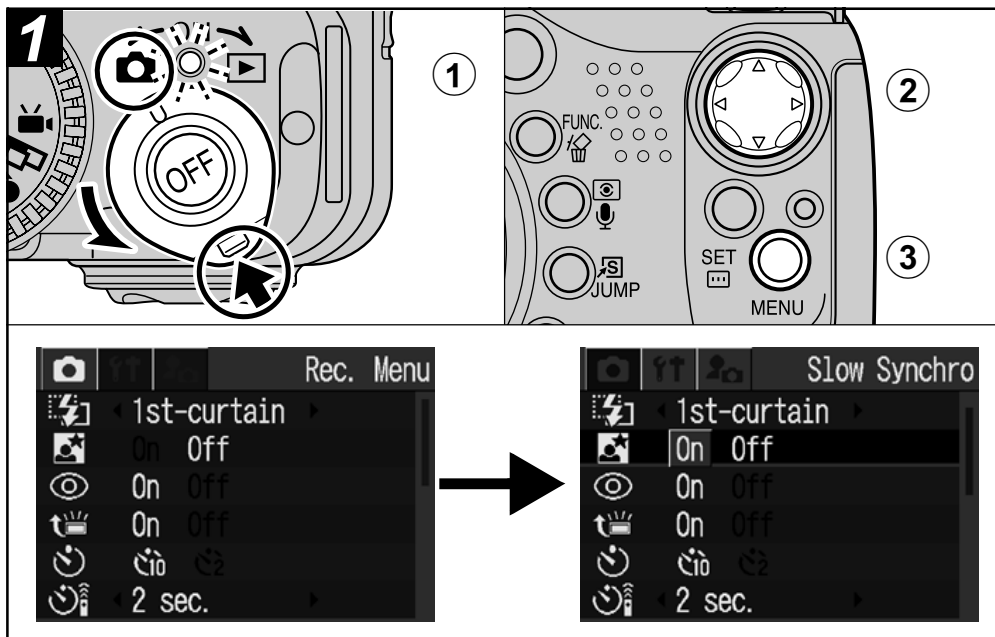

① Power the camera in  (Shooting) mode (p. 19) and press the MENU button.

The [ (Rec.)] menu appears.

② Select [Slow Synchro] using the ▲ or ▼ arrow on the omni selector.

③ Select [On] using the ◀ or ▶ arrow on the omni selector and press the MENU button.



When shooting with a high ISO sensitivity and using the built-in flash, there is more of a chance of overexposure the closer you are to the subject.



- ◆ The flash fires with automatic adjustments when [Flash Adjust] is set to [Auto] in the Rec. menu. When shooting in **M** mode, or with [Flash Adjust] set to [Manual], the flash fires with the manually set adjustments.
- ◆ When [Flash Adjust] is set to [Auto], the flash fires twice. A pre-flash will fire and will be followed by the main flash. The pre-flash is used by the camera to obtain the subject's exposure data so that the main flash can be set to the optimal intensity for the shot.
- ◆ The fastest shutter speed for flash synchronization is 1/250 second. The camera automatically resets the shutter speed to 1/250 second if a faster speed is selected.
- ◆ Shots cannot be taken while the flash is charging.

- ◆ The flash may take up to approximately 10 seconds to charge in some cases. Actual times will vary according to usage and the battery charge.
- ◆ The flash exposure and the flash output can be changed (p. 89).
- ◆ When shooting with [Slow Synchro] set to [On], camera shake may become a factor. We recommend the use of a tripod.
- ◆ The flash setting is saved when the camera is turned off in the **P**, **Tv**, **Av** and **M** shooting modes.

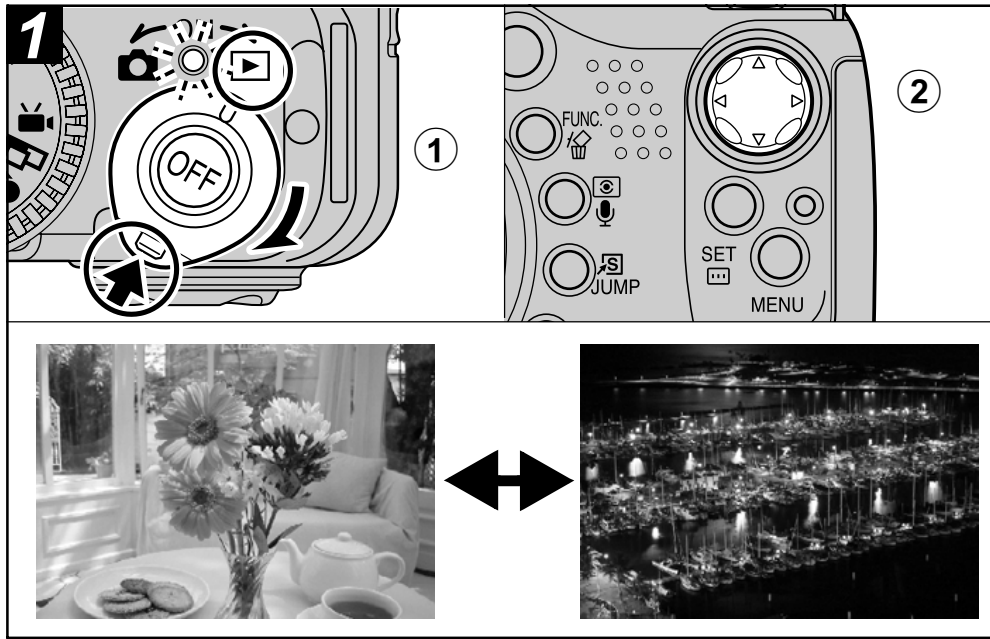

① Turn the mode lever to the right to set the camera to Playback mode.

The last recorded image appears on the LCD monitor (or viewfinder).

② Move between images using the ◀ or ▶ arrow on the omni selector.

- Use ◀ to move to the previous image and ▶ to move to the next. Holding ◀ or ▶ moves more rapidly between images, but the images will not appear as clearly.

- When you press the ◀ or ▶ arrow on the omni selector after having pressed the **JUMP** button, the camera jumps 10 images behind or ahead. If you press the **JUMP** button once more, the camera returns to the single image playback screen.
- Press the **DISPLAY** button to show the data for the displayed image (p. 24).
- Press the  button to quickly delete the displayed image (p. 43).



You may not be able to play back images that have been shot with another camera or edited on a computer with other software applications.

+ Magnifying Images

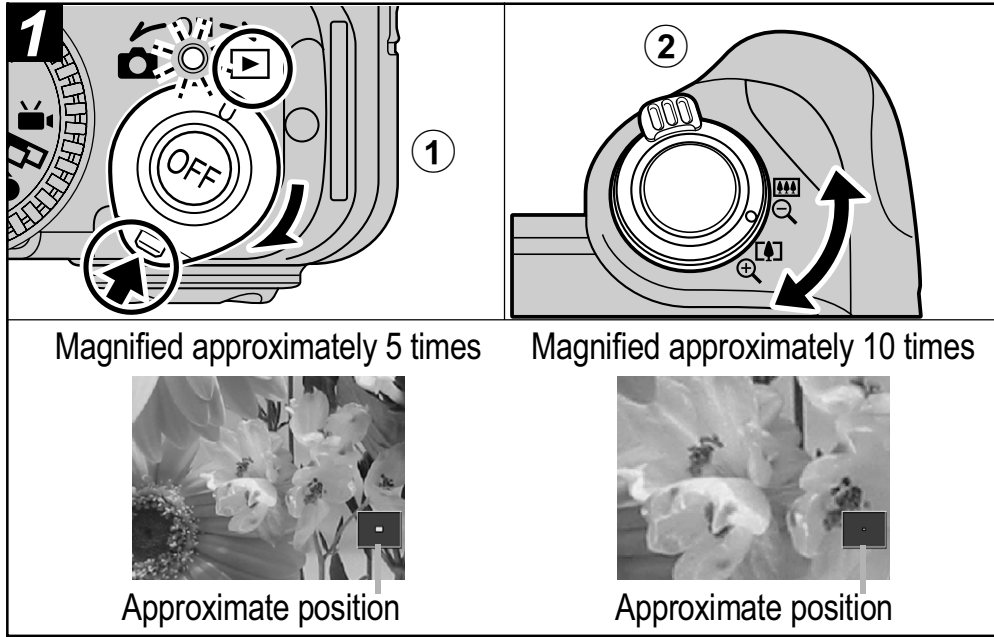

① Turn the mode lever to the right to set the camera to Playback mode.

② Turn the zoom lever toward **+** to magnify the image and toward **-** to cancel the magnified display.

- In single image playback, images can be magnified up to 10 times. Hold the **SET** button down and turn the zoom lever toward **+** to cycle through each setting, approximately 2.5 times, to approximately 5 times and 10 times.



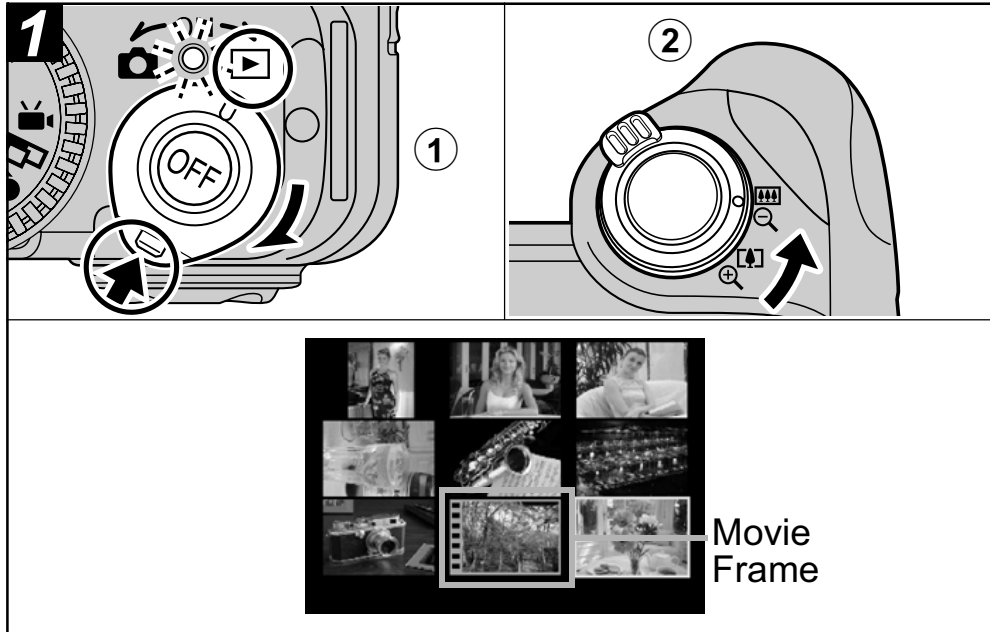

- You can move around the magnified image using the **◀**, **▶**, **▲** or **▼** arrow on the omni selector.
- Movie frames and index playback images cannot be magnified.
- You can magnify an image while it is displayed on the LCD monitor (or viewfinder) immediately after the image is shot (p. 31).

Viewing Images in Sets of Nine (Index Playback)

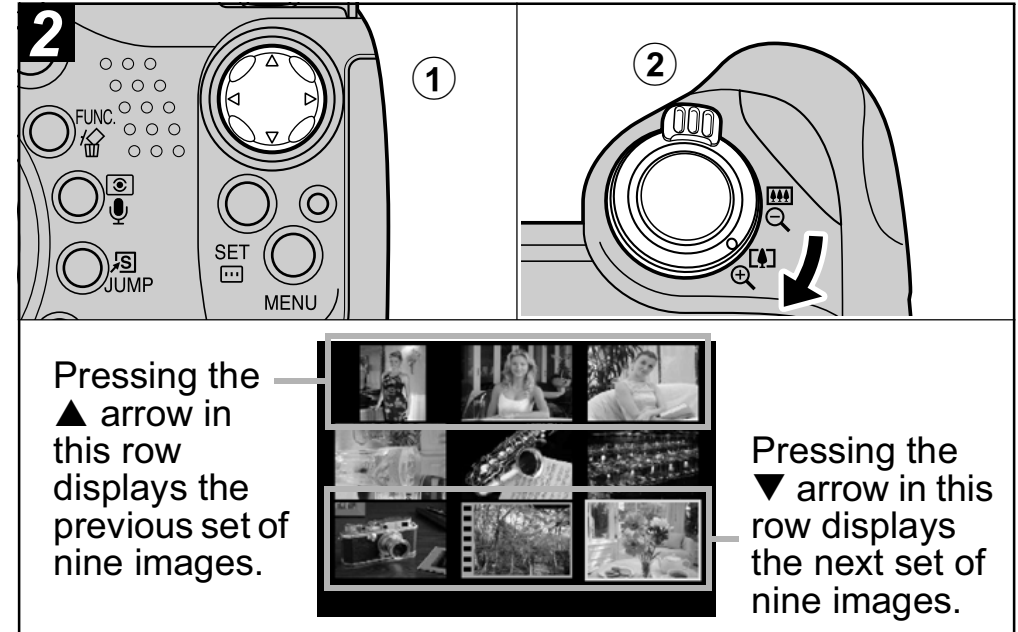

- ① Turn the mode lever to the right to set the camera to Playback mode.
- ② Turn the zoom lever toward .
 - Nine images appear at once (index playback).



- ① Change the image selection using the , ,  or  arrow on the omni selector.
 - Press the **DISPLAY** button to show the data for the displayed image (p. 24).
- ② Turn the zoom lever toward .
 - Index playback cancels and the display reverts to single image playback.

JUMP Jumping Between Images

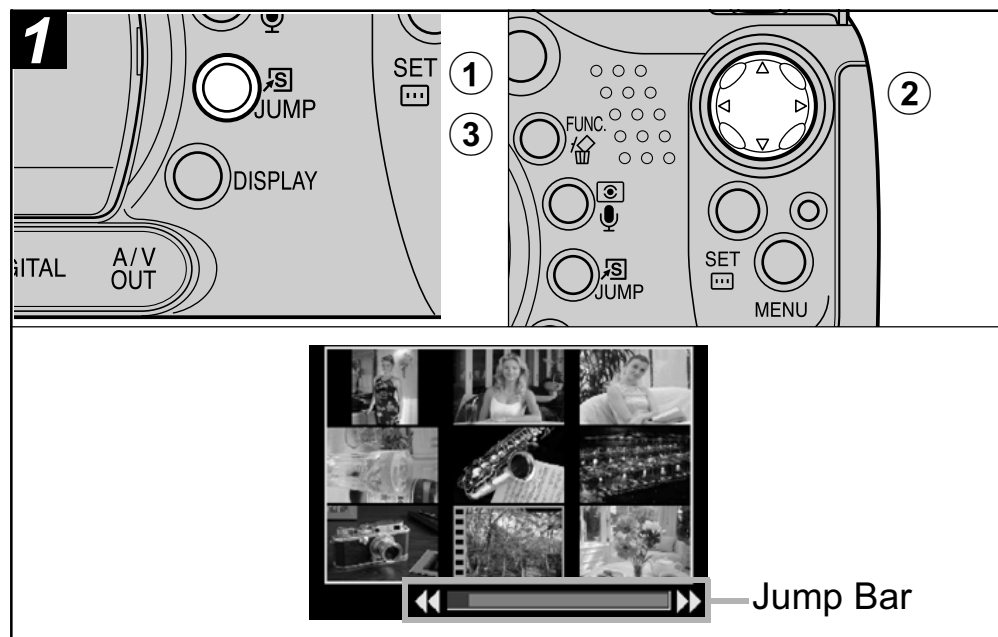

- **Index Playback:** The previous or next 9 images are displayed.

③ Press the JUMP button.

The jump bar disappears and the camera reverts to single image playback or index playback.

① Press the JUMP button while in single image playback (p. 39) or index playback (p. 41).

The jump bar appears.

② Change the image selection using the ◀ or ▶ arrow on the omni selector.

- **Single Image Playback:** The 10th image ahead or behind is displayed.

Please note that erased images cannot be recovered. Exercise caution before erasing a file.

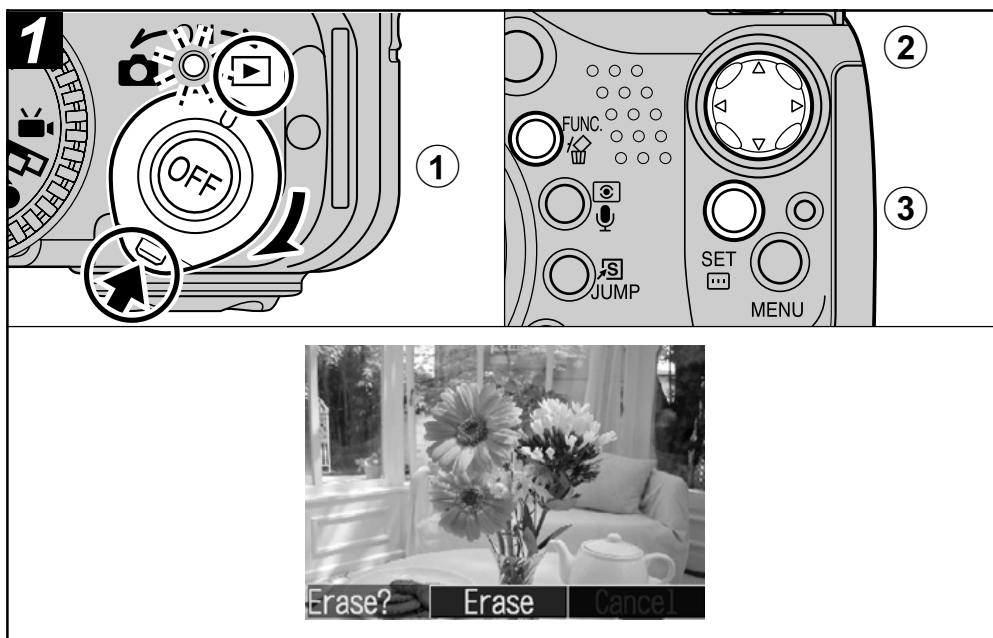

- ① Turn the mode lever to the right to set the camera to Playback mode.

The last recorded image appears on the LCD monitor (or viewfinder).

- ② Select the image you wish to erase using the ◀ or ▶ arrow on the omni selector and press the .
- ③ Select [Erase] using the ◀ or ▶ arrow on the omni selector.
 - To cancel instead of erasing, select [Cancel].
 - Protected images cannot be erased with the erase function (p. 106).

Erasing All Images

Please note that erased images cannot be recovered. Exercise caution before erasing a file.

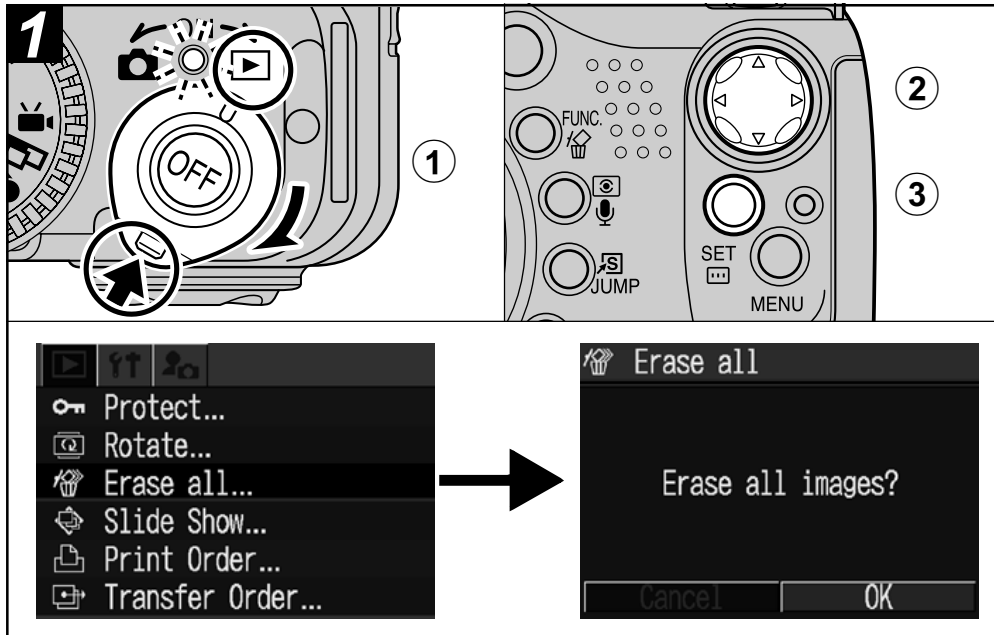

① Turn the mode lever to the right to set the camera to Playback mode.

The [ (Play)] menu appears.

② Select [Erase all] using the ▲ or ▼ arrow on the omni selector.

③ Select [OK] using the ◀ or ▶ arrow on the omni selector.

- To cancel instead of erasing, select [Cancel].
- Protected images cannot be erased with the erase function (p. 106).

 The [Erase all] function erases all the image data recorded on the CF card. You should format the CF card when you want to erase not only image data but also all the data contained on the card (p. 18).

Settings fitting the shooting conditions of your subject can easily be set using the mode dial.

Landscape



Use this mode to shoot spacious landscape scenes.

Portrait



Use this mode when you want the subject to appear sharp and the background to blur.

Movie (p. 53)

Use this mode to shoot movies. Sound is also recorded simultaneously.



Stitch Assist (p. 47)



Night Scene



Use this mode to capture human subjects against the backdrop of an evening sky or night scene. The subject is illuminated with light from the flash while the backdrop is captured at a slow shutter speed.

Fast Shutter



Use this mode to shoot fast moving objects.

Slow Shutter



Use this mode to shoot moving objects to make them appear blurred, such as river rapids.

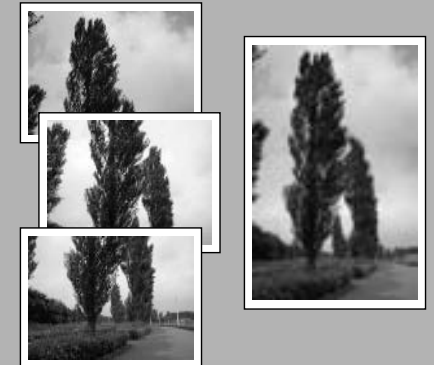

Use this mode when taking shots that you want to combine into a panorama.

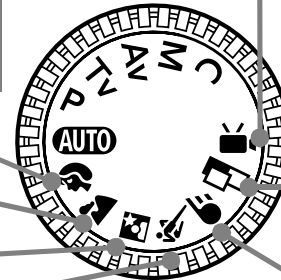

Shooting Panoramic Images (Stitch Assist)

Use this mode to shoot a series of overlapping frames for merging (stitching) into a large panoramic image using a computer.

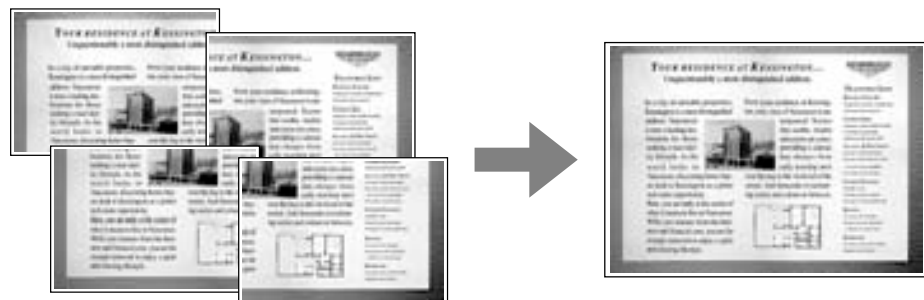
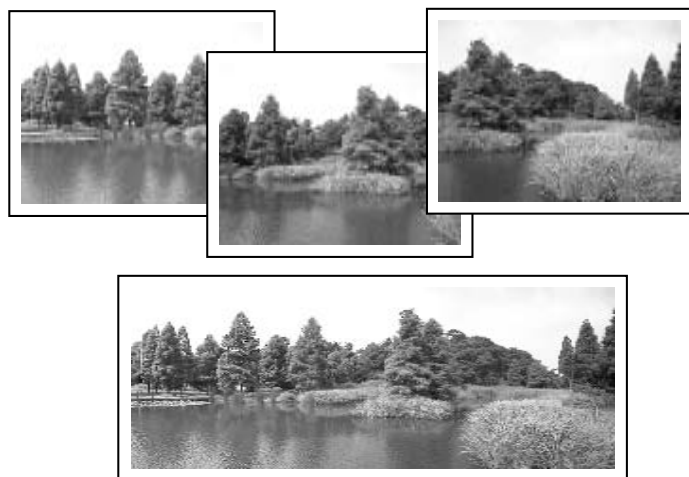

Please use the bundled PhotoStitch program to merge the images on a computer.

Framing a Subject

PhotoStitch detects the overlapping portions of adjoining images and merges them. When composing shots, try to include a distinctive item (landmark, etc) in the overlapping portions.









- ◆ Compose each frame so that it overlaps 30 to 50% of the adjoining image. Try to keep the vertical misalignment to within 10% of the image height.
- ◆ Do not include moving items in the overlap.
- ◆ Do not try to stitch images that include both distant and close subjects. Objects may appear warped or doubled up.
- ◆ Make the brightness in each image consistent. The final image will appear unnatural if the difference in brightness is too great.
- ◆ For good results, pan (swivel) the camera to take successive shots.

- ◆ To shoot close-ups, slide the camera over the subject, keeping it parallel as you move.

Shooting

Images can be shot in the following 5 sequences in Stitch Assist mode.

	Horizontally, left to right
	Horizontally, right to left
	Vertically, bottom to top
	Vertically, top to bottom
	Clockwise starting at the top left

- ◆ See page 166 for settings that can be changed in this mode.
- ◆ A custom white balance setting (p. 79) cannot be set in  mode. To use a custom white balance setting, first set it in another shooting mode.
- ◆ The settings in place for the first image are locked in and cannot be changed for subsequent shots.
- ◆ A TV cannot be used as the monitor for shooting in this mode.

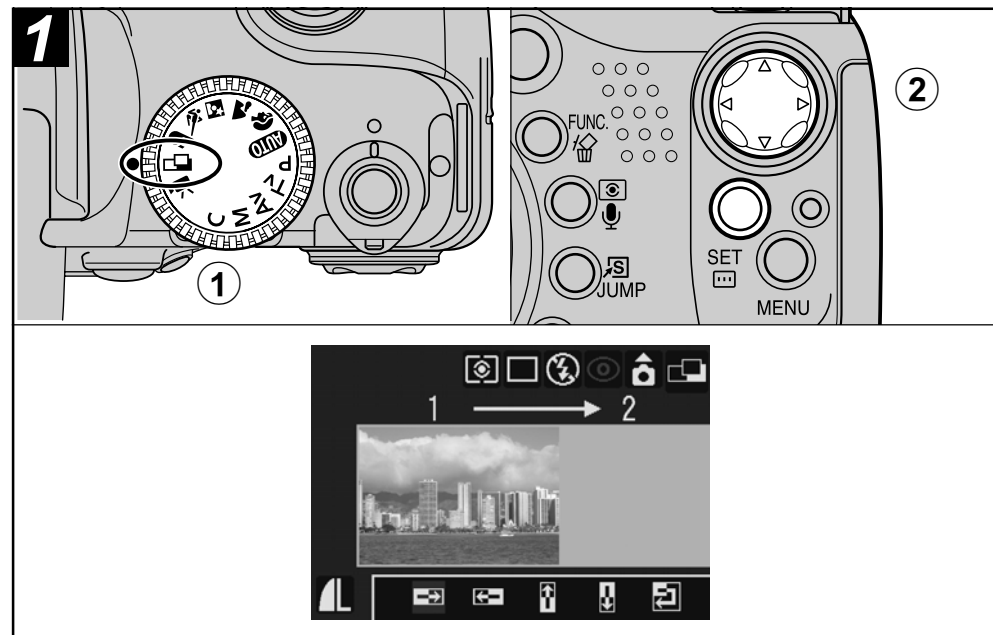

- ① Turn the mode dial to .
- ② Select the shooting sequence using the ◀ or ▶ arrow on the omni-selector, then press the SET button.
The shooting sequence is set.
 - You can also press the shutter button directly to shoot without pressing the SET button.
- ③ Shoot the first image.
 - The exposure and white balance settings are set and locked with the first image.

Using the Self-timer

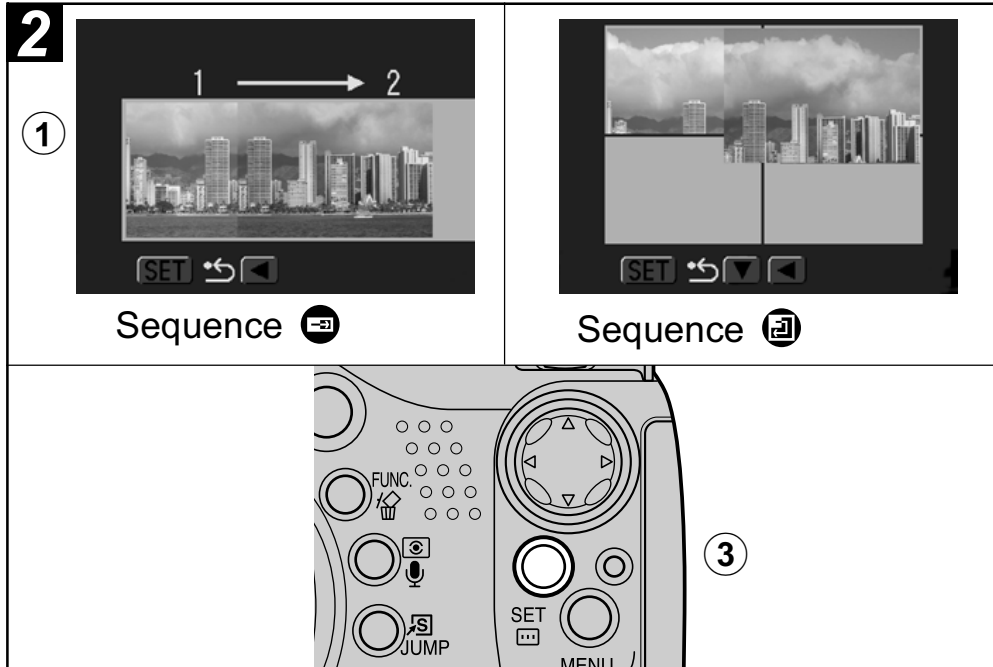

① Compose and shoot the second image so that it overlaps the first.

- Minor discrepancies in the overlap can be corrected with the software.
- An image can be retaken. Press the ◀, ▶, ▲ or ▼ arrow on the omni selector to return to that frame.
- A maximum of 26 images can be recorded either horizontally or vertically.

② Use the same procedures to shoot the remaining frames.

③ Press the SET button after the last shot.

Mode Dial

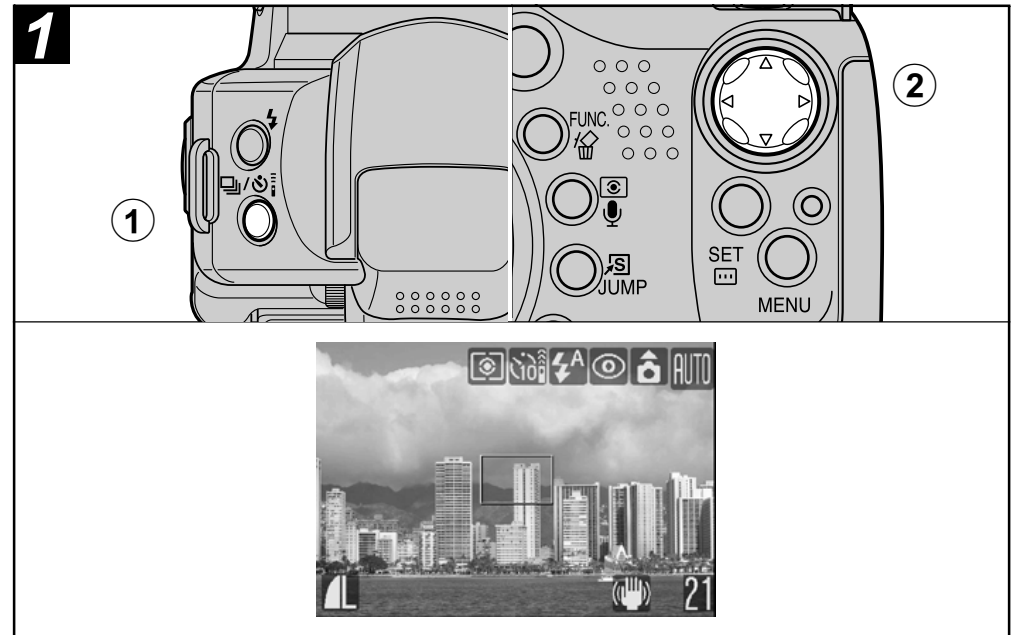

① Press the button.

The current setting is displayed.

- Pressing the  button cycles between settings.

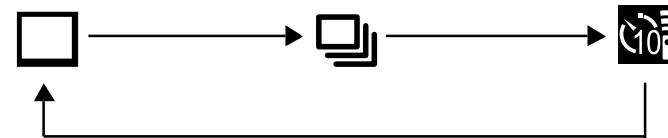



Digital Zoom





Mode Dial





With the combined optical and digital zoom functions, images can be zoomed as follows: 13x, 16x, 20x, 25x and 32x.



- ◆ Images become coarser the more they are digitally zoomed.
- ◆ The lens will zoom the maximum optical telephoto setting and stop. To further zoom the image digitally, turn the zoom lever toward  once more.
- ◆ To zoom back out, turn the zoom lever toward .



- You can switch between the  and  options through the [ (Rec.)] menu (p. 64).
- When the self-timer is set to  () , the shutter activates 10 (2) seconds after the shutter button is pressed fully.

② Check that or is displayed and shoot the image.

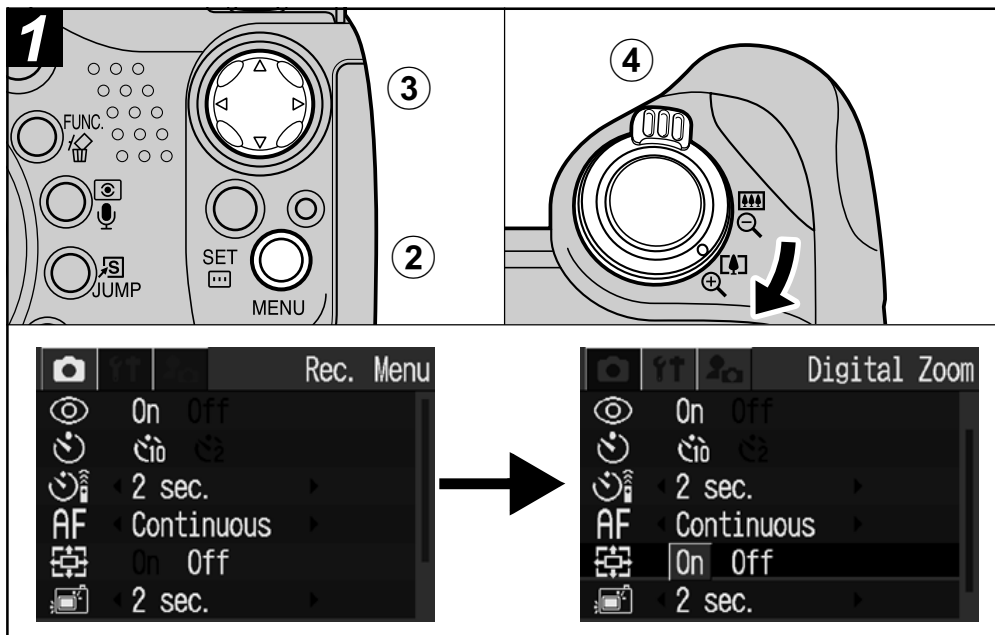
- When  is selected, the self-timer sounds and the self-timer lamp starts blinking when the shutter button is pressed all the way. The self-timer sound and the blinking get faster two seconds before the shutter activates.
- When  is selected, the self-timer lamp blinks fast from the beginning. The shutter activates in two seconds.
- You can change the self-timer sound by changing the setting in [Selftimer Sound] in the [ (My Camera)] menu (p. 67).



④ Turn the zoom lever toward  and shoot the image.

- ① Turn the mode dial to any Shooting mode except for  or .
- ② Press the MENU button to display the  (Rec.) menu.
- ③ Select [Digital Zoom] using the ▲ or ▼ arrow, select [On] using the ◀ or ▶ arrow on the omni selector and press the MENU button.

Continuous Shooting

Mode Dial



Use this mode to shoot successive frames while the shutter button is fully pressed.



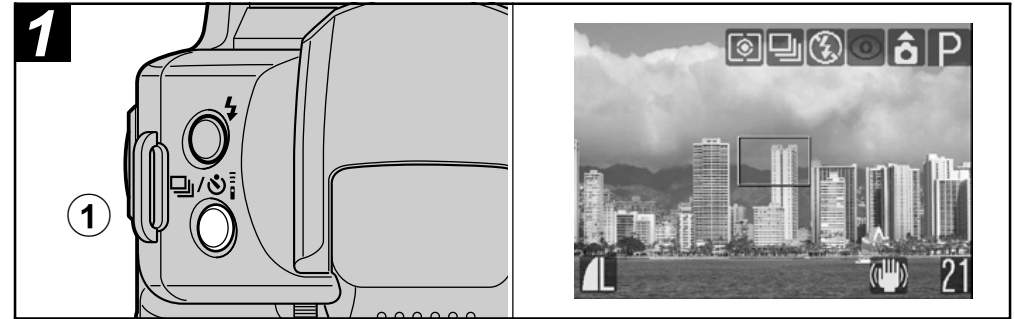

- ◆ The interval between frames may lengthen somewhat when the internal memory becomes full.
- ◆ The flash can be used, but the interval between images will lengthen to accommodate the flash recharge time.



① Press the / button.

The current setting is displayed.

- Pressing the  /  button cycles between settings.

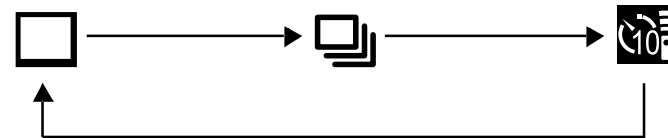

② Select .

Movie Mode

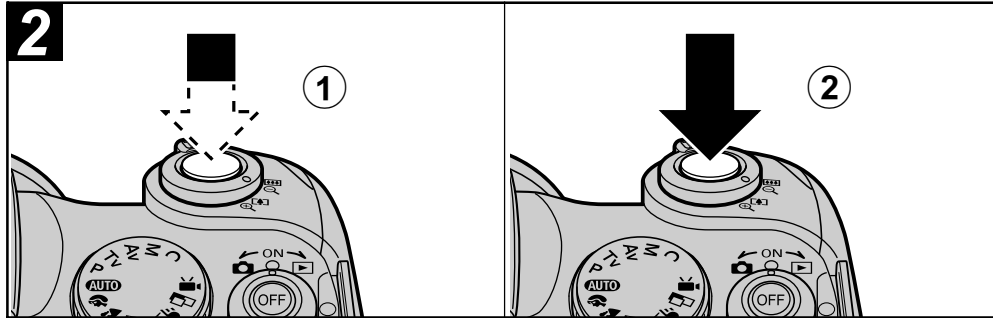

① Press the shutter button halfway to lock the focus.

② Press the shutter button all the way to shoot.

- Shooting will stop when the shutter button is released.

- The shooting speed is 1.7 shots/second.*

* Large/Fine (These figures reflect Canon's testing standard. The actual figures will vary according to the shooting conditions and settings.)

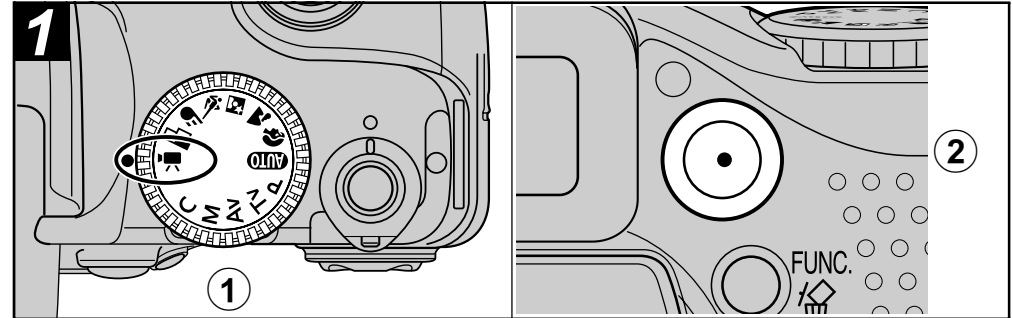

① Turn the mode dial to .

The maximum recording time in seconds appears.

② Press the Movie button.



The camera beeps once and shooting starts. Sound is recorded simultaneously.

- When the Movie button is pressed again, the camera beeps twice and shooting stops.

- The tally lamp blinks red during movie recording and goes off when the recording session is over. When [Tally Lamp] is set to [Off] in the Rec. menu, the lamp does not blink (p.65).

- The maximum movie recordable time in one movie shooting is approx. 1 hour and the maximum recording capacity is 1 GB. These figures will vary according to the type of CF cards and their capacity.
When recording time reaches 1 hour, when the CF card is about to become full or when the file size is about to reach 1 GB, the remaining shooting time displayed on the lower right corner of the LCD monitor (or viewfinder) will blink red and recording will stop automatically approximately 10 seconds later.
- Recording times and recording capacities may vary according to your camera usage (shooting conditions, exterior conditions, etc.) and the capacity of your CF card. When the camera's internal available memory is low, the ! mark appears in the lower right corner of the LCD monitor (or viewfinder), indicating that shooting will automatically end soon, regardless of the remaining shooting time and recording capacity.

If the ! mark frequently appears, try the following methods to solve the problem.

- Format the CF card before recording (p. 18).
- Avoid using the zoom during shooting.
- Set the resolution to  (320 x 240) or set the frame rate to  (15fps).
- Use a high speed CF card (such as the CF-512MSH CF card).



- The recording time may not display properly during shooting or filming may stop unexpectedly with the following types of CF cards.

- Slow recording cards
- Cards formatted on a different camera or a computer
- Cards which have had images recorded and erased repeatedly

Although the recording time may not display properly during shooting, the movie will be recorded correctly on the CF card. Recording time will display properly if you format the CF card in this camera (excluding slow recording CF cards).

- Be careful not to touch the microphone while shooting.
- If the indicator blinks after a shot, this indicates that the movie is being written to the CF card. You cannot shoot again until it stops blinking.

- When the camera's internal temperature rises,  appears in red on the lower left corner of the LCD monitor (or viewfinder). If the temperature continues to rise, shooting ends automatically to protect the CF card or micro drive from overheating, the [Overheated! Shutting down.] message appears and the camera powers off. If this happens, store the camera for approximately 30 minutes and wait until it has completely cooled down before resuming use. The CF card or micro drive may heat up but this does not constitute a malfunction. However, for still image shooting, there is no need to wait 30 minutes before resuming use.



- ◆ See page 166 for settings that can be changed in this mode.
- ◆ See page 32 for resolution and frame rate information.
- ◆ Sound is recorded monaurally.
- ◆ There is no shutter sound in Movie mode.
- ◆ QuickTime 3.0 or higher is required to play back movie files (AVI/Motion JPEG) on a computer. (QuickTime (for Windows) is bundled on the supplied Digital Camera Solution Disk. On the Macintosh platform, QuickTime 3.0 or later is generally bundled with Mac OS 8.5 or later operating system.)

- ◆ The following operations are available during movie recording:
 - Zooming (excluding the digital zoom)
 - AF lock: Press the **MF** button. **AF-L** appears on the LCD monitor (or viewfinder). You can cancel AF lock by pressing the **MF** button again.
 - AE lock, exposure compensation: Press the **AE-L/AF-ON** button. The exposure compensation bar appears on the LCD monitor (or viewfinder). You can change the exposure using the ◀ or ▶ arrow. You can cancel AE lock by pressing the **AE-L/AF-ON** button again.
 - Image Stabilizer: Press the **IS** button to turn it on or off.

Changing the Frame Rate

The number of frames shot per second when shooting movies can be selected.

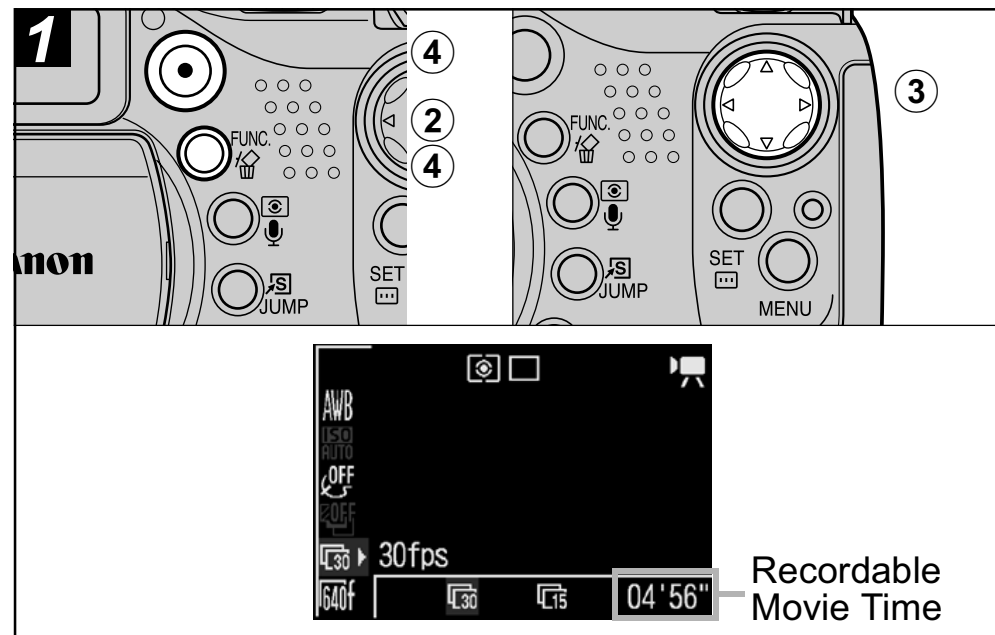

- ① Turn the mode dial to **MOVIE**.
- ② Press the **FUNC.** button.
- ③ Select **30*** (30fps) using the ▲ or ▼ arrow on the omni selector and select the frame rate you wish to set using the ◀ or ▶ arrow.

Viewing/Editing Movies

* The current setting is displayed.

: Shoots 30 frames per second

: Shoots 15 frames per second

- The number of recordable frames per second varies according to the selected resolution setting (p. 151).
- You can shoot the movie right after selecting settings by pressing the Movie button. This screen will appear again once the movie is shot.

④ Press the FUNC. button then press the Movie button to start shooting.



You can play back movies recorded with the Movie mode and delete unwanted portions from the beginning or the end of movie clips.



- Protected movies cannot be edited (p. 106).
- It may take some time to save an edited movie as a new file depending on the file size. If the batteries run out of charge partway through, edited movie clips cannot be saved. When editing movies, use separately sold, fully charged AA-size NiMH batteries or Compact Power Adapter CA-PS700.



You may experience frame dropping if you are using a slow reading CF card and the recording resolution and frame rate are set to the following settings.

-  (640 x 480 Fine) resolution
-  (640 x 480) resolution and  (30fps) frame rate

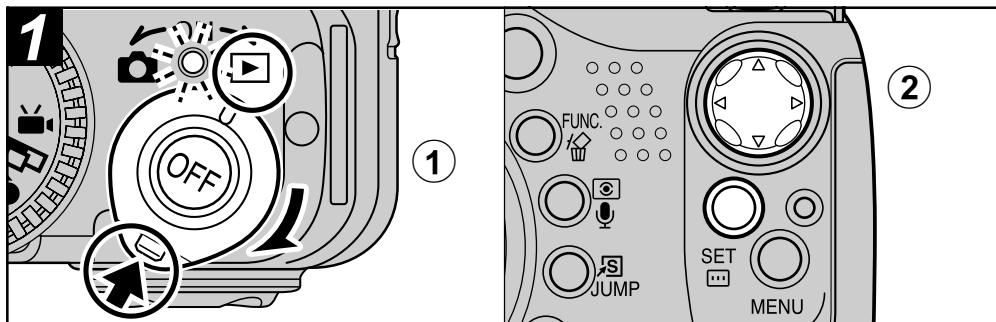

This mark appears on movie files



- ① Turn the mode lever to the right to set the camera to Playback mode.
- ② Select a movie using the ◀ or ▶ arrow on the omni selector, then press the SET button.

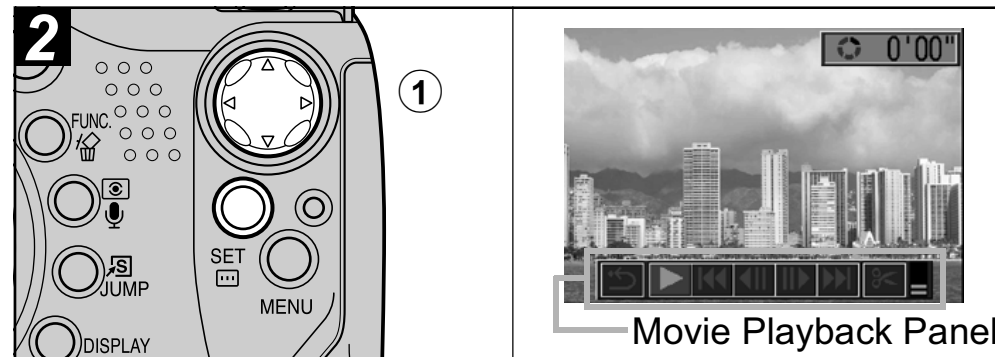

- ① Select a button from the movie playback panel using the ◀ or ▶ arrow on the omni selector, then press the SET button.

Movie Playback Panel

- ◀ (Exit): Returns to the screen in Step 1
- ▶ (Play): Plays back the movie images and sounds
- ◀◀ (First Frame): Shows the first frame
- ◀|| (Previous Frame): Rewinds if the SET button is held down
- ||▶ (Next Frame): Fast forwards if the SET button is held down
- ▶▶ (Last Frame): Shows the last frame
- ✂ (Edit): Edits the movie → Step 3

Playback Operations

▲▼: Adjusts the volume during playback

SET: Pauses playback. Press again to resume playback.

When Playback Ends



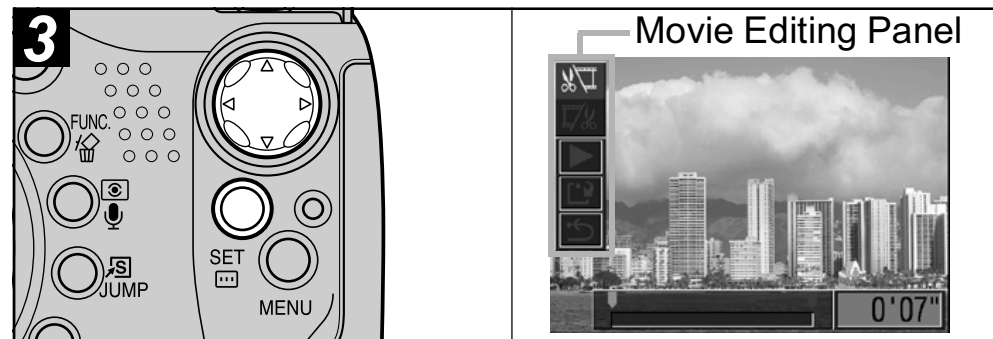

The last frame remains displayed when playback ends.

SET: Displays the movie playback panel. Press again to play back the movie again from the first frame.

- You may experience frame dropping and audio breakup when playing back a movie on a computer with insufficient system resources.
- The volume at which movies play back can also be adjusted in the Play menu.
- Please adjust the audio sound level on the TV when viewing movie files on a TV.
- If you are not editing the movie, operations end here.



① **Select a button from the movie editing panel using the ▲ or ▼ arrow on the omni selector, then press the SET button.**

-  (Cut Beginning): Deletes frames in the first half of the movie
-  (Cut End): Deletes frames in the second half of the movie
-  (Play): Plays back the temporarily edited movie
-  (Save): Saves the movie
-  (Exit): Cancels movie editing and reverts to the screen in step

2

- Movies with an original length of 1 second or more can be edited in 1-frame units.

② **Select the range you wish to edit using the ◀ or ▶ arrow.**

③ **Select ▶ (Play) using the ▲ or ▼ arrow and press the SET button.**

The temporarily edited movie will start playing.

- The movie will stop if you press the **SET** button while it is playing.

④ **Select ↶ (Save) using the ▲ or ▼ arrow and press the SET button.**

- When ↷ (Exit) is selected, the edited movie is not saved and the camera reverts to the screen in Step ②.

⑤ **Select [Overwrite] or [New File] using the ◀ or ▶ arrow and press the SET button.**

[Overwrite]: Saves the edited movie under the same file name as the original movie. The original data is deleted.

[New File]: Saves the edited movie under a new file name. The original data is not deleted.

- When there is not enough space left on the CF card, only the overwrite function is available. If this happens, ▲ appears on the counter of the movie editing bar.

Selecting Settings by Pressing the FUNC. Button (Only in Shooting Mode)

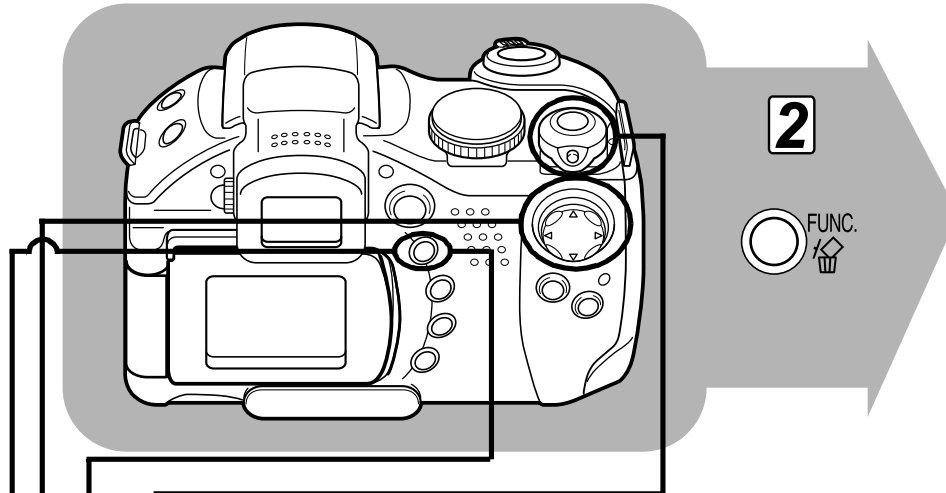

- 1 Turn the mode lever to .
- 2 Press the **FUNC.** button.
- 3 Press the **▲** or **▼** arrow to select a function item.
- 4 Press the **◀** or **▶** arrow to select setting contents.
- 5 Press the **FUNC.** button.
- 6 Shoot the image.

3 Select a function item using **▲** or **▼**

Exposure Compensation (± 0) → p. 78

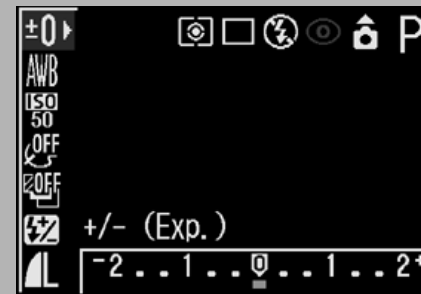

White Balance () → p. 79



ISO Speed () → p. 81



Photo Effect () → p. 82

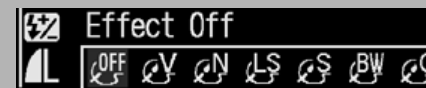

Bracket () → p. 84

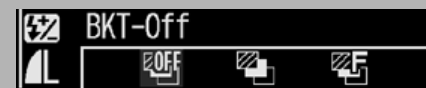

() items in parentheses show default settings.

4 Select setting contents using **◀** or **▶**

Flash Adjust (± 0) → p. 89

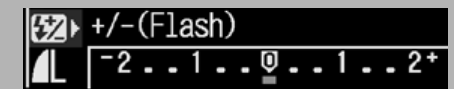

Flash Output → p. 89

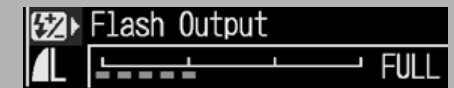

Resolution (L) → p. 32

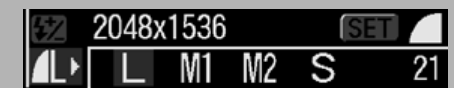

Compression () → p. 32



Resolution and Movie () → p. 32

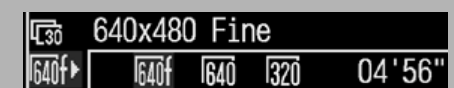

Frame Rate () → p. 56

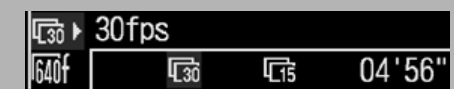

5



6

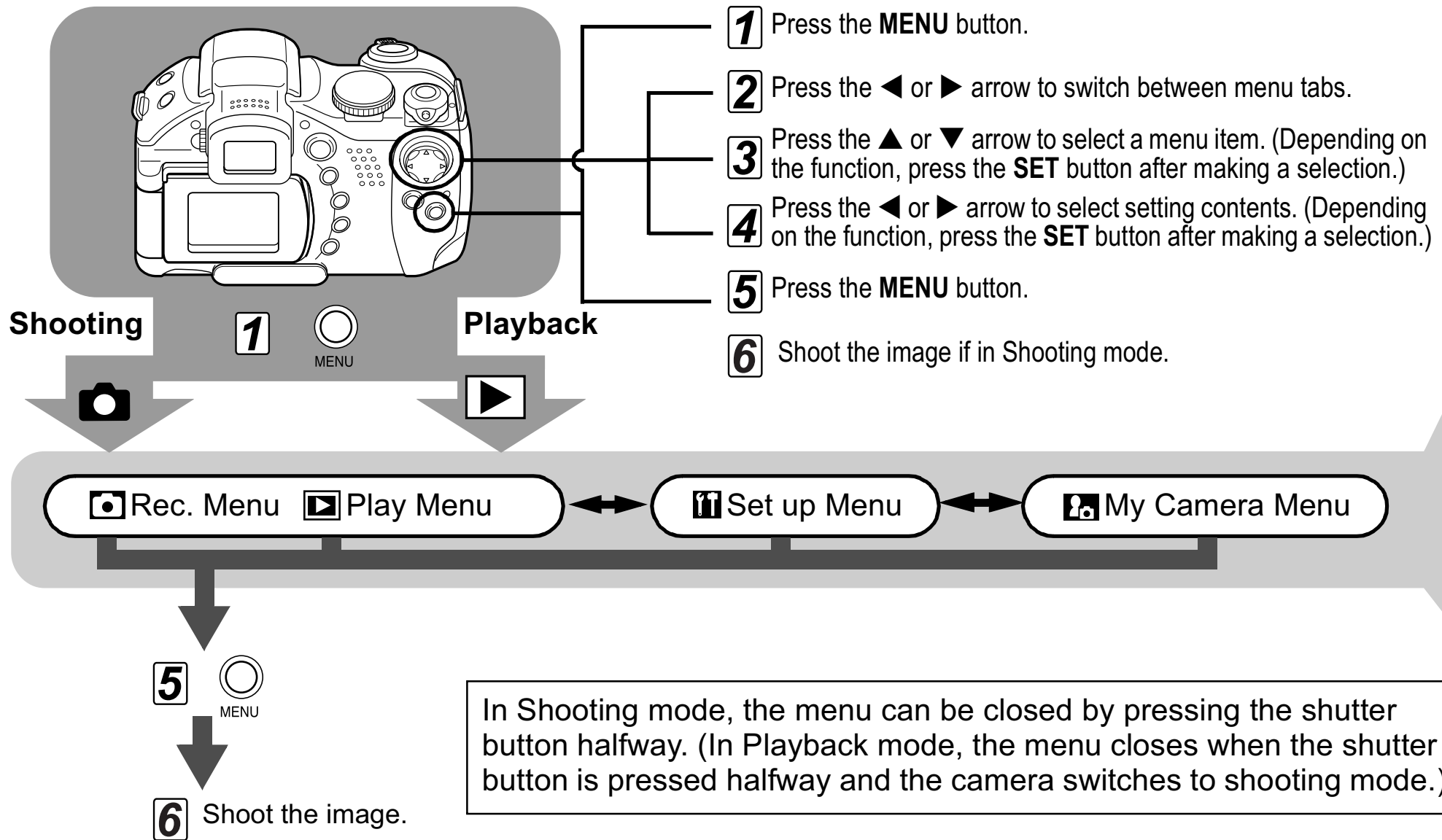

Shoot the image.

Selecting Settings by Pressing the **MENU** Button

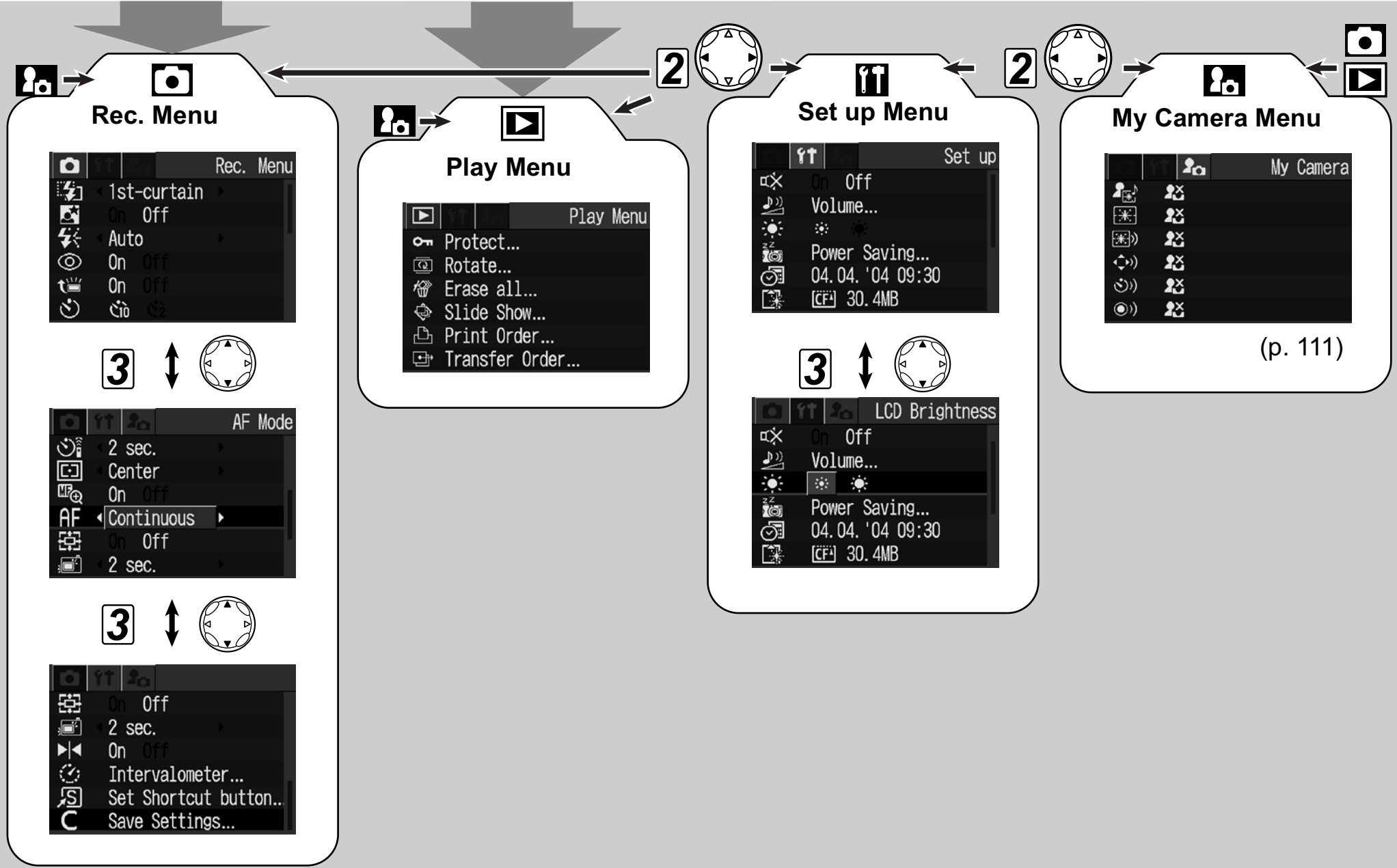







- ◆ Some menu items may not be available for selection according to the shooting mode (p. 166).
- ◆ You can apply a desired image and sound to  and  in the My Camera menu. For details, see *Registering the My Camera Settings* (p. 111) or the *Canon Digital Camera Software Starter Guide Disk*.
- ◆ Camera settings can be reset to the default values (p. 68).

Rec. Menu

Menu Item	Setting content	Reference Page
Flash Sync	Sets the timing at which the flash fires. 1st-curtain*/2nd-curtain	p. 90
Slow Synchro	Sets whether or not the flash will fire with a slow shutter speed. On/Off*	p. 36
Flash Adjust	Sets whether or not the flash is adjusted automatically. Auto*/Manual	p. 89
Red-eye	Sets whether or not the red-eye reduction lamp fires when the flash fires. On*/Off	p. 35
Flash Pop-up	Sets whether or not the flash pops up automatically. On*/Off When set to [Off] the flash will not fire automatically.	p. 34
Self-timer	Sets the duration before the self-timer releases the shutter once the shutter button is pressed.  10 sec.* /  2 sec.	p. 49
Wireless Delay	Sets the duration before the self-timer releases the shutter once the remote control shutter button is pressed. 0 sec./2 sec.* / 10 sec.	p. 136

Menu Item	Setting content	Reference Page
Spot AE Point	Sets the option of [Spot AE Point] (one of the light metering modes) to Center (the AE point is fixed to the center) or AF Point (the AE point corresponds to the AF point). Center*/AF Point	p. 76
MF-Point Zoom	Sets whether or not the focusing point is magnified when using the manual focus. On*/Off	p. 95
AF Mode	Sets the frequency of autofocus activation. Continuous*/Single	p. 97
Tally Lamp	Sets whether or not the tally lamp blinks during movie recording. On*/Off	p. 53
Digital Zoom	Sets whether or not the digital zoom combines with the optical zoom to zoom images. On/Off*	p. 50
Review	Sets the duration images display on the LCD monitor (or in the viewfinder) after the shutter button is released. Off/2 sec.* to 10 sec.	p. 31
Reverse Disp.	Sets whether or not the image is reversed when the LCD monitor is tilted 180 degrees toward the lens. On*/Off	p. 26

Menu Item	Setting content	Reference Page
Intervalometer	Shoots automatically at set intervals. 2* to 100 shots 1* to 60 min.	p. 91
Set shortcut button	Selects functions to be registered on the  (Shortcut) button.	p. 69
Save Settings	Saves settings selected in the Rec. menu and the function menu to the mode dial's C mode.	p. 98

* Default setting







Play Menu

Menu Item	Setting content	Reference Page
Protect	Protects images from accidental erasure.	p. 106
Rotate	Rotates images 90 or 270 degrees clockwise in the display.	p. 100
Erase all	Erases all images from a CF card (excluding protected images).	p. 44
Slide Show	Plays images in an automated slide show.	p. 102
Print Order	Sets the images that will be printed on a direct print compatible printer or at a photo lab service, the number of copies and other parameters.	p. 121

Menu Item	Setting content	Reference Page
Transfer Order	Specifies images before downloading to a computer.	p. 126

11 Set up Menu



Menu Item	Setting content	Reference Page
Mute	<p>Set [On] to mute the start-up sound, operation sound, selftimer sound and shutter sound all at once.</p> <ul style="list-style-type: none"> ● If you set [Mute] to [On], no sound will be heard even when any sound item in the My Camera menu is set to 1, 2 or 3 (On). ● Note that the error warning signal beeps even when the Mute setting is [On]. <p style="text-align: center;">On/Off*</p>	-
Volume	Adjusts the volume of camera operations.	-
① Start-up Vol.	Adjusts the Start-up Sound volume when the camera powers up.	p. 19
② Operation Vol.	Adjusts the Operation Sound volume for operation buttons other than the shutter button.	-
③ Selftimer Vol.	Adjusts the volume of the Selftimer Sound informing you that the photo will be taken in 2 seconds.	p. 49

Menu Item	Setting content	Reference Page
④ Shutter Vol.	Adjusts the Shutter Sound volume when the shutter button is pressed all the way. There is no shutter sound in Movie mode.	p. 28
⑤ Playback Vol.	Adjusts the sound volume when a movie or sound memo is played.	p. 57, 101
Settings of Above Items (① - ⑤)	<p>Off  1  2*  3  4  5</p>	-
LCD Brightness	<p>Sets the brightness level of the LCD monitor.</p> <p> (Normal)* /  (Bright)</p>	-
Power Saving	<p>Sets whether or not the camera automatically powers down or the LCD monitor (or viewfinder) goes off after a specified period of time elapses without camera operation.</p> <p>Auto Power Down</p> <p style="text-align: center;">On*/Off</p> <p>Display Off</p> <p>10 sec./20 sec./30sec./1 min.*/2 min./3 min.</p>	p. 107
Date/Time	Sets the date, time and date format.	p. 21
Format	Formats (initializes) a CF card.	p. 18
File No. Reset	<p>Sets how file numbers are assigned to images when new CF cards are inserted.</p> <p style="text-align: center;">On/Off*</p>	p. 110

Menu Item	Setting content	Reference Page
Auto Rotate	Sets whether or not images shot with the camera on end are automatically rotated in the display. On/Off*	p. 108
Distance Units	Sets the format of the displayed distance units of the MF indicator. m/cm* or ft/in	p. 96
Language	Sets the language used in the menus and messages on the LCD monitor (or in the viewfinder). English*/Deutsch/Français/Nederlands/Dansk/Suomi/Italiano/Norsk/Svenska/Español/Chinese/Japanese You can change the language during image playback by holding the SET button and pressing the JUMP button. (Except when the camera is connected to a printer)	p. 23
Video System	Sets the video output signal standard. NTSC/PAL	p. 118



* Default setting

My Camera Menu

You can select the theme, start-up image and sound, shutter sound, operation sound and selftimer sound used on this camera. These are called My Camera settings. You can also customize the  and  options for each item with images from the CF card and newly recorded sounds or by using the supplied software. See the *Canon Digital Camera Software Starter Guide Disk* for details.

Menu Item	Setting content	Reference Page
Theme	Selects a common theme for each my Camera settings item.	p. 111
Start-up Image	Sets the start-up image when you turn on the camera.	p. 111
Start-up Sound	Sets the start-up sound when you turn on the camera.	p. 111
Operation Sound	Sets the sound when the omni selector or any button other than the shutter button is operated.	p. 111
Selftimer Sound	Sets the sound informing you that the photo will be taken in 2 seconds.	p. 111
Shutter Sound	Sets the shutter sound when you depress the shutter button. There is no shutter sound while a movie is being shot.	p. 111

Resetting the Settings to Default

Menu Item	Setting content	Reference Page
My Camera menu settings content	 (Off)/ 1 */  / 	—

* Default setting

You can reset the menu and button operation settings to default.

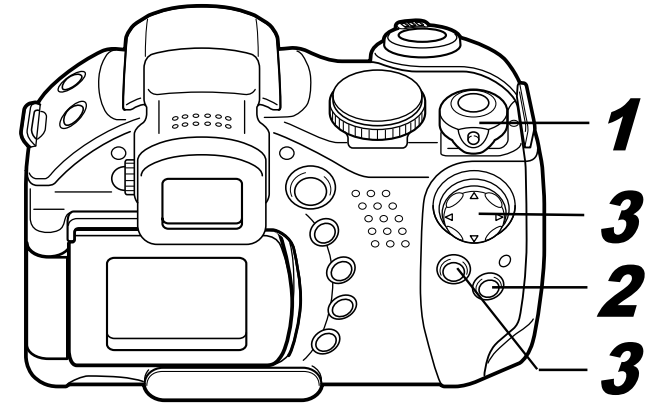

1 Turn the mode lever to  or  to power up the camera.

2 Press the MENU button for longer than 5 seconds.

The message "Reset settings to default?" appears on the LCD monitor (or viewfinder).



3 Select [OK] using the  or  arrow on the omni selector, then press the SET button.

Resetting starts.

- The normal screen resumes when resetting is complete.
- To cancel resetting, select [Cancel] instead of [OK].



- The following settings cannot be reset to default:
 - The [Date/Time], [Language] and [Video System] options in the [f1] (Set up) menu (p. 66, 67)
 - White balance data set with the custom white balance function (p. 79)
 - Newly registered My Camera settings
- Settings cannot be reset when the camera is connected to a computer or printer.



When the camera is in Shooting mode and the mode dial is set to **C**, only the **C** mode settings will revert to default.

Registering Settings to the Shortcut Button

Frequently used functions can be registered to the  (Shortcut) button.

The following functions can be registered:

- Resolution (Still Images Only)*
- Image Quality (Movies Only)
- ISO Speed (Still Images Only)
- Frame Rate (Movies Only)
- Photo Effect
- AF Lock (Still Images Only)
- AE Lock (Still Images Only)
- White Balance
- Display Off

* Default setting

Registering a Function

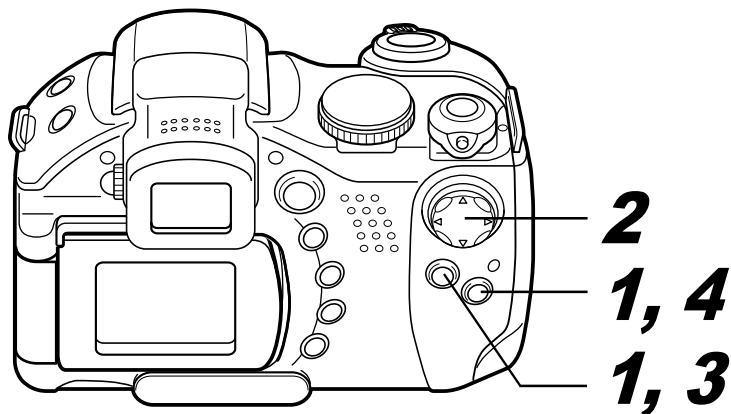

1 Select [Set shortcut button] from the [Rec.] menu and press the SET button.

- See *Selecting Menus and Settings* (p. 62).

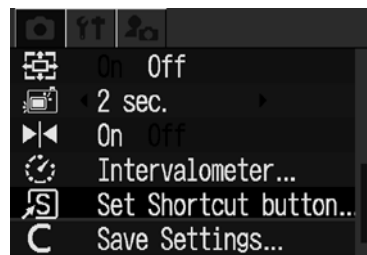

2 Select the function you wish to register using the ◀ or ▶ arrow.



- If an "x" mark appears on the lower right of the icon, Mode dial set to **AUTO**, you can still register this function but the current shooting mode will be retained and pressing the shortcut button will not activate the function (the icon of the registered function will not appear). If this happens, change the setting of the mode dial.

3 Press the SET button.

4 Press the MENU button.

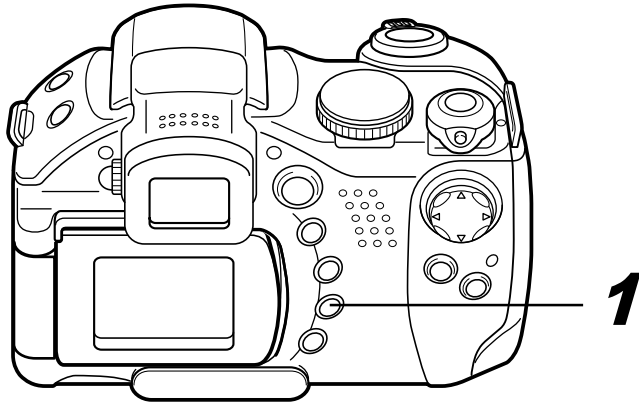

Using the Mode Dial (Creative Zone)

Using the Shortcut Button



1 Press the Button.

The registered function is recalled and its icon appears on the LCD monitor or viewfinder (except if the display is off).

- Pressing the  button cycles between setting values of the registered functions.
- Functions that are not available in the current shooting mode will not appear even if they are selected. Change the shooting mode setting and press the  button again.



2 Shoot the image.

Mode Dial

P Tv Av M

You can freely select camera settings such as the shutter speed and aperture value to suit your shooting purposes.

After settings are made, shooting procedures are the same as for the **AUTO** mode (p. 27).

How to Use the Mode Dial

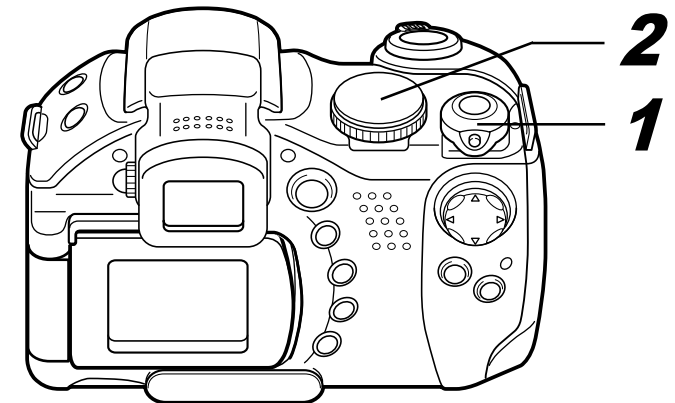

1 Check that the camera is in Shooting mode.

- The power/mode indicator lights orange.

2 Turn the mode dial, select the function you wish to use and shoot the image.

- The camera operates in the following ways according to the selected function:





Shutter Speed Aperture value

P	The camera automatically sets the shutter speed and aperture value.
Tv	The user selects a shutter speed using the ◀ or ▶ arrow.
Av	The user selects an aperture value using the ◀ or ▶ arrow.
M	The user selects the shutter speed using the ◀ or ▶ arrow and the aperture value using the ▲ or ▼ arrow.

- The shutter speed and aperture value will show on the LCD monitor (or viewfinder). The correct exposure has been set if the shutter speed and aperture value show in white on the LCD monitor (or viewfinder).
- The shutter speed and aperture value will show in red on the LCD monitor (viewfinder) when the correct exposure cannot be obtained.

- In **P**, **Tv** or **Av**, the combinations of shutter speeds and aperture values can be changed within the same exposure setting (p. 73).



- ◆ See page 166 for settings that can be changed in this mode.
- ◆ For information on the relation between the aperture value and shutter speed, see page 73.
- ◆ Please note that camera shake becomes a factor at low shutter speeds. If the camera shake warning  appears in the LCD monitor (or viewfinder), try the following procedures to solve the problem.
 - Use the  (image stabilizer) function (p. 29).
 - Use a tripod.

P Program AE

Use the program AE mode to have the camera automatically set the shutter speed and aperture value to match the brightness of the scene.

- If a correct exposure cannot be obtained, use the following methods to solve the problem.
 - Use the flash.
 - Change the ISO speed setting.
 - Change the light metering mode.

Differences between the P and AUTO Modes.

The following settings can be adjusted in P mode, but not in AUTO mode.

- Exposure Compensation
- ISO Speed
- Flash Exposure Compensation
- Flash (Flash on, Slow Synchro, 2nd-curtain)
- Photo Effect
- Light Metering Mode
- Intervalometer
- FE Lock
- White Balance
- Bracket Mode
- Continuous Shooting
- Manual Focus
- AE Lock

TV Setting the Shutter Speed

When you set the shutter speed in the shutter speed-priority AE mode, the camera automatically selects an aperture value to match the brightness. Faster shutter speeds allow you to catch an instantaneous image of a moving subject while slower speeds create a flowing effect and allow you to shoot without a flash in dark areas.

- Adjust the shutter speed using the ◀ or ▶ arrow when the image is underexposed (insufficient light) or overexposed (too much light) and the correct exposure cannot be obtained.

- The nature of CCD image sensors is such that noise in the recorded image increases at slow shutter speeds. This camera, however, applies special processing to images shot at shutter speeds slower than 1.3 seconds to eliminate the noise, thereby producing high-quality images. Nevertheless, a certain amount of processing time may be required before the next image can be shot.
- The aperture value and shutter speed change according to the zoom state as follows.

	Aperture value	Shutter Speed (seconds)
Wide Angle End*1	f/2.8 – f/5.0	to 1/1250
	f/5.6 – f/8.0	to 1/2000
Telephoto End*2	f/3.1 – f/5.6	to 1/1250
	f/6.3 – f/8.0	to 1/2000

*1 Maximum wide angle

*2 Maximum telephoto

- The fastest shutter speed for flash synchronization is 1/250 second. The camera automatically resets the shutter speed to 1/250 second if a faster speed is selected.

Shutter Speed Display

The numbers in the table below indicate the shutter speed in seconds. 1/160 indicates 1/160 second. Also, quote marks indicate the decimal place, so that 0"3 indicates 0.3 second and 2" indicates 2 seconds.

15"	13"	10"	8"	6"	5"	4"	3"2	2"5	2"	1"6	1"3	1"
0"8	0"6	0"5	0"4	0"3								
1/4	1/5	1/6	1/8	1/10	1/13	1/15	1/20	1/25				
1/30	1/40	1/50	1/60	1/80	1/100	1/125						
1/160	1/200	1/250	1/320	1/400	1/500	1/640						
1/800	1/1000	1/1250	1/1600	1/2000								

Av Setting the Aperture

When you set the aperture in the aperture-priority AE mode, the camera automatically selects a shutter speed to match the brightness.

Selecting a lower aperture value (opening the aperture) allows you to fade the background and create a beautiful portrait. A higher aperture value (closing it) brings the entire range from foreground to background into focus. The larger the aperture value, the greater the range of the image brought into clear focus.

- Adjust the aperture value using the ◀ or ▶ arrow when the image is underexposed (insufficient light) or overexposed (too much light) and the correct exposure cannot be obtained.
- Some aperture values cannot be selected depending on the zoom position.
- In this mode, the maximum shutter speed with synchronized flash is 1/250 second. The aperture value setting may therefore be changed automatically to match the synchronized flash speed even if its value was set previously.

Aperture Setting Display



The larger the aperture value, the smaller the lens aperture.

f/2.8	f/3.1	f/3.2	f/3.5	f/4.0	f/4.5	f/5.0	f/5.6	f/6.3
f/7.1	f/8.0							

M Manually Setting the Shutter Speed and Aperture

You can manually set the shutter speed and aperture to achieve a particular effect. This is convenient for shooting fireworks and other images where it is difficult to set the correct exposure automatically.

Selecting an AF Frame

- The brightness of the LCD monitor (or viewfinder) matches the selected shutter speed and aperture value. When you select a fast shutter speed or shoot a subject in a dark place and set the flash to  (Flash On (red-eye reduction)) or  (flash On) the image will always be bright.
- When you press the shutter button halfway, the difference between the standard exposure* and the selected exposure appears on the LCD monitor (or viewfinder). If the difference is more than 2 stops, "-2" or "+2" appears on the LCD monitor (or viewfinder).

* The standard exposure is calculated by the AE function according to the selected metering method.

Mode Dial

P Tv Av M

The AF frame indicates the area of the composition on which the camera focuses and can be set manually to the desired area. This is convenient for focusing accurately on an off-center subject to obtain the composition you desire.

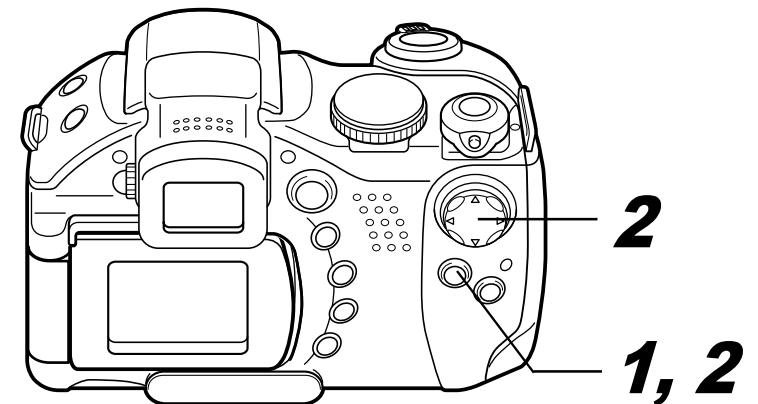

However, the AF frame is fixed to center-point when the digital zoom is used, even if you previously set the AF frame to the position you desire.



1 Press the button.

The AF frame appears in green.

2 Move the AF frame to the desired area using the ▲, ▼, ◀ or ▶ arrow, then press the button.

- You can immediately shoot the image using the selected AF frame by pressing the shutter button instead of pressing the  button.
- The AF frame will move back to its original position (Center) if you hold down the  button.





- ◆ For an explanation of the AF frame colors, please refer to page 24.
- ◆ The AF frame is locked to center-point when using the digital zoom.
- ◆ When the Spot AE Point is selected as the light metering mode, you can use the selected AF frame as the Spot AE Point (p. 76).

Switching between Light Metering Modes

Mode Dial

P Tv Av M

Evaluative metering is the default light metering mode. This can be switched to another metering mode.

	Evaluative Light Metering	The camera divides images into several zones for light metering. The camera evaluates the complex lighting conditions, such as the position of the subject, the brightness, the background, the direct light, and the backlighting, and adjusts the settings to the correct exposure for the main subject. This mode is particularly well-suited for backlight conditions and general photography.
	Center-Weighted Averaging	Averages the exposure from the entire image, but places more weight on the subject at the center.
	Spot AE Point	Meters the area within the spot AE point frame.
	Center	Locks the spot metering frame to the center of the LCD monitor.
	AF Point	Moves the spot AF point to the AF frame.

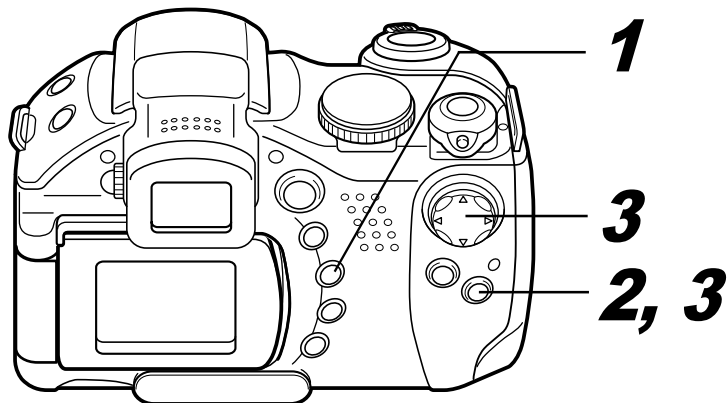

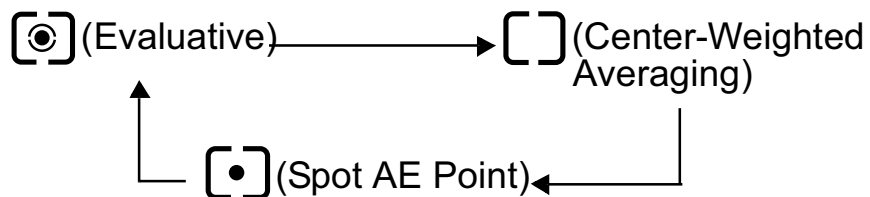

1 Press the button to select a metering mode.

- Each press of the  button changes the metering mode as follows.



- The icon of the currently selected light metering mode appears on the LCD monitor (or viewfinder).

If you have selected  (Spot AE point), go to step 2. If you have selected  (Evaluative Light Metering) or  (Center-Weighted Averaging), shoot the image.

2 In the [(Rec.)] menu, select [Spot AE Point].

- See *Selecting Menus and Settings* (p. 62).

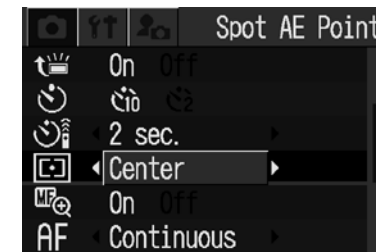

3 Select [Center] or [AF Point] using the ◀ or ▶ arrow, then press the MENU button.

- When [Spot AE point] is set to [Center], the spot AE point frame appears at the center of the LCD monitor (or viewfinder), and when [Spot AE Point] is set to [AF point], it appears inside the selected AF frame.



e.g. Center

Spot AE Point

Adjusting the Exposure

Mode Dial



Adjust the exposure compensation setting to avoid making the subject too dark when it is backlit or shot against a bright background.

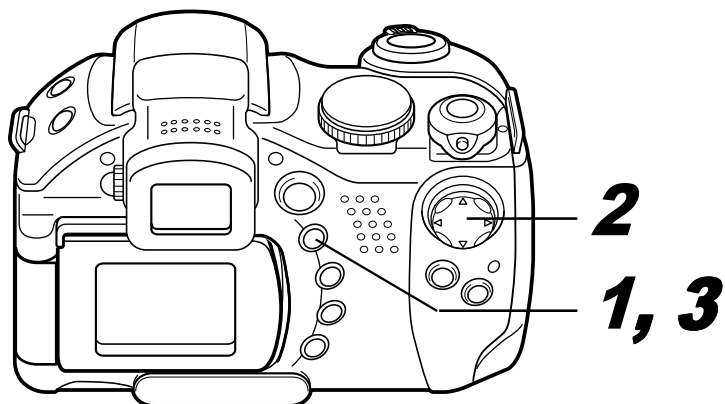

1 Press the **FUNC.** button.

2 Select **±0*** (+/- (Exp.)) using the **▲** or **▼** arrow, and set the exposure using the **◀** or **▶** arrow.



* The current setting is displayed.

- The settings can be adjusted in 1/3-stops in the range of -2EV to +2EV.
- You can shoot the image right after selecting settings by pressing the shutter button. This screen will appear again, once the image is shot.

3 Press the **FUNC.** button.

- To cancel the exposure compensation, return the setting to **0** using the **◀** or **▶** arrow.

 Exposure settings can be made/canceled even in [movie icon] mode (p. 53).

WB Adjusting the Tone (White Balance)

Mode Dial



When the white balance mode is set to match the light source, the camera reproduces colors more accurately.

Combinations of setting contents and light source are as follows.

	Auto	Settings are automatically set by the camera
	Daylight	For recording outdoors on a bright day
	Cloudy	For recording under overcast, shady or twilight skies
	Tungsten	For recording under tungsten and bulb-type 3-wavelength fluorescent lighting
	Fluorescent	For recording under warm-white, color-white or warm-white (3-wavelength) fluorescent lighting
	Fluorescent H	For recording under daylight fluorescent, or daylight fluorescent-type 3-wavelength fluorescent lighting
	Flash	For flash photography
	Custom	For setting a custom value with a white sheet of paper, etc., to obtain the optimal white balance for the conditions.

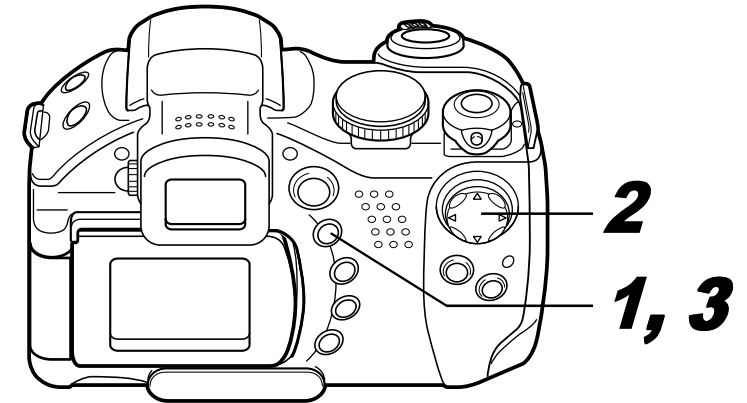

1 Press the **FUNC.** button.

2 Select **AWB*** (Auto) using the **▲** or **▼** arrow and select the desired setting using the **◀** or **▶** arrow.



* The current setting is displayed.

- Please see page 80 regarding the custom setting.
- You can shoot the image right after selecting settings by pressing the shutter button. This screen will appear again, once the image is shot.

3 Press the **FUNC.** button.

The white balance cannot be adjusted when the photo effect is set to (Sepia) or (B/W) (p. 82).

Setting a Custom White Balance

In the following cases, the white balance may not be correctly adjusted. Use  (Custom) to adjust the white balance.

- Shooting subjects of monotone color (such as sky, sea or forest)
- Shooting with a peculiar source of light (such as a mercury-vapor lamp)

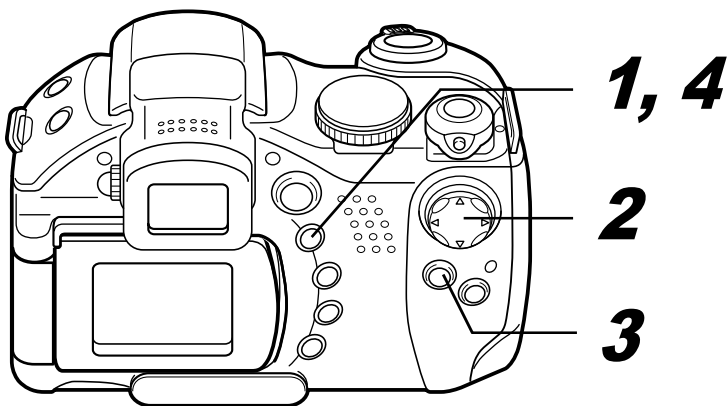

1 Press the **FUNC.** button.

2 Select **AWB*** (Auto) using the **▲** or **▼** arrow and select  (Custom) using the **◀** or **▶** arrow.



* The current setting is displayed.

3 Aim the camera at a white paper or cloth, or gray card and press the **SET** button.

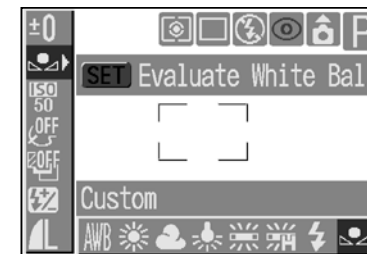

The white data is recorded.

- Aim the camera so that the white paper or cloth, or gray card, completely fills the center of the frame.
- You can shoot the image right after selecting settings by pressing the shutter button. The menu displays again after the shot, allowing you to change the settings easily.

4 Press the **FUNC.** button.









◆ You are recommended to set the white balance when shooting in the following conditions.

- The shooting mode is set to **P** and the exposure compensation and flash exposure adjustment are set to **±0**.

The correct white balance may not be obtained when the exposure is incorrect (image is completely black or white).

ISO Changing the ISO Speed

- **The zoom is positioned to the telephoto end setting.**
Set the digital zoom to [Off].
 - **A mode other than  is selected.**
In  mode, white balance data cannot be read.
 - **The flash is set to  (Flash On) or  (Flash Off).**
Use the same flash setting as the one that will be used for shooting when you set the white balance. If the white balance setting conditions and shooting conditions are not the same, the correct white balance may not be obtained.
When the flash is set to   (Auto with red-eye reduction) or  (Auto), the flash may fire while the white data is recorded to the custom white balance. If this happens, make sure the flash also fires when you shoot the image.
 - **The ISO speed is set to the same setting to shoot the image.**
- ◆ The custom white balance will not be canceled even if you reset camera settings to default (p. 68).

Mode Dial

P Tv Av M

By raising the ISO speed, you can shoot bright images even poor lighting conditions. This function is convenient when you want to prevent camera shake, shoot without the flash or shoot with a faster shutter speed in dark conditions.

You can choose from the following speeds: Auto, 50, 100, 200 and 400.

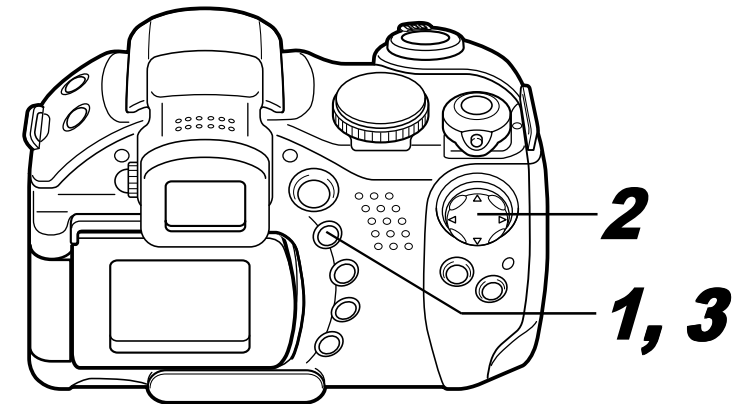

1 Press the FUNC. button.

2 Select * (ISO Speed) using the ▲ or ▼ arrow and select the desired setting using the ◀ or ▶ arrow.



* The current setting is displayed.

- You can shoot the image right after selecting settings by pressing the shutter button. The menu displays again after the shot, allowing you to change the settings easily.

3 Press the **FUNC.** button.







- Higher ISO speeds increase the image noise. To take clean images, use as low an ISO speed as possible.
- The AUTO setting selects the optimal ISO speed. It will automatically raise the speed when the light from the flash is insufficient to illuminate the subject matter.

Changing the Photo Effect

Mode Dial



You can shoot with different saturation and contrast color effects.

	Photo Effect Off	Records with no effect.
	Vivid	Emphasizes the contrast and color saturation to record in bold color.
	Neutral	Tones down the contrast and color saturation to record neutral hues.
	Low Sharpening	Records subjects with softened outlines.
	Sepia	Records in sepia tones.
	B/W	Records in black and white.
	Custom Effect*	You can freely set the contrast, sharpness and color saturation.

* **P**, **Tv**, **Av** and **M** modes only

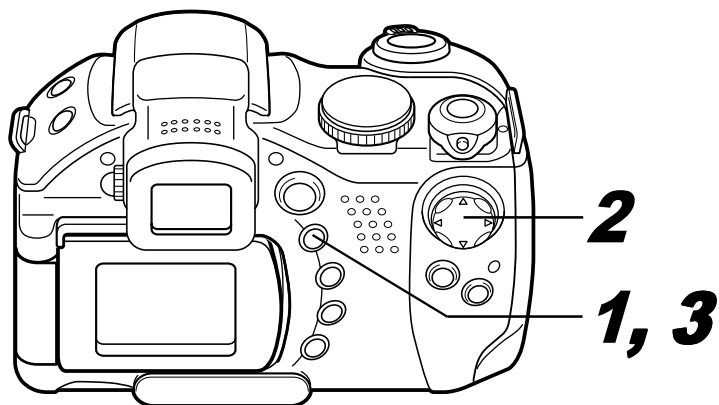

1 Press the FUNC. button.

2 Select * (Effect Off) using the ▲ or ▼ arrow and select the desired setting using the ◀ or ▶ arrow.

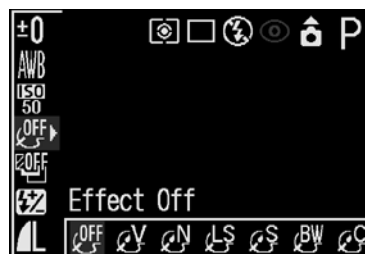

* The current setting is displayed.

When is selected

- A screen allowing you to set the contrast, sharpness and color saturation appears when you press the **SET** button. Select the item you wish to set using the ▲ or ▼ arrow, set it using the ◀ or ▶ arrow and press the **SET** button.

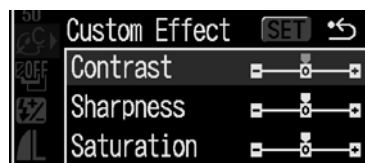

- You can shoot the image right after selecting settings by pressing the shutter button. The menu displays again after the shot, allowing you to change the settings easily.

Contrast

- This function allows you to adjust the degree of brightness.
- Select from - (Weak), 0 (Neutral) and + (Strong).



Sharpness

- This function allows you to adjust how sharply outlines are defined.
- Select from - (Weak), 0 (Neutral) and + (Strong).

Saturation

- This function allows you to adjust the color depth.
- Select from - (Weak), 0 (Neutral) and + (Strong).

3 Press the FUNC. button.

 The white balance cannot be set when  (Sepia) or  (B/W) mode is selected.

Auto Exposure Bracketing (AEB Mode)

Mode Dial

P Tv Av

In this mode, the camera automatically changes the exposure within a set range to take three shots after you press the shutter button once.

You can adjust AEB settings in 1/3 stops within the range of -2EV to +2EV of the standard exposure setting. AEB settings can be combined with exposure compensation settings (p. 78) to extend the adjustment range. The images are recorded in the following order: Standard exposure, underexposure and overexposure.

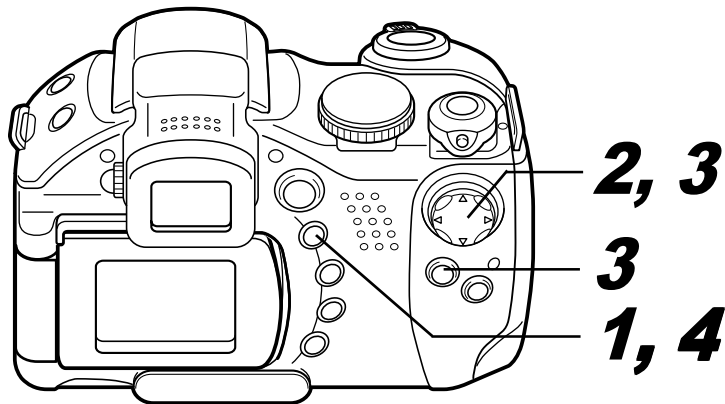

1 Press the **FUNC.** button.

2 Select * (BKT-Off) using the **▲** or **▼** arrow.

* The current setting is displayed.





3 Select , press the **SET** button and adjust the compensation range using the **◀** or **▶** arrow.



- Use **▶** to expand the range and **◀** to contract it.
- You can shoot the image right after selecting settings by pressing the shutter button. The menu displays again after the shot, allowing you to change the settings easily.

4 Press the **FUNC.** button.

- Select  (BKT-Off) in Step **3** to cancel the AEB mode.

 The AEB mode cannot be used for flash photography. If the flash fires, only one image gets recorded.

Focus Bracketing (Focus-BKT Mode)

Mode Dial



P Tv Av M

You can shoot three images while the focus changes automatically when shooting with the manual focus.

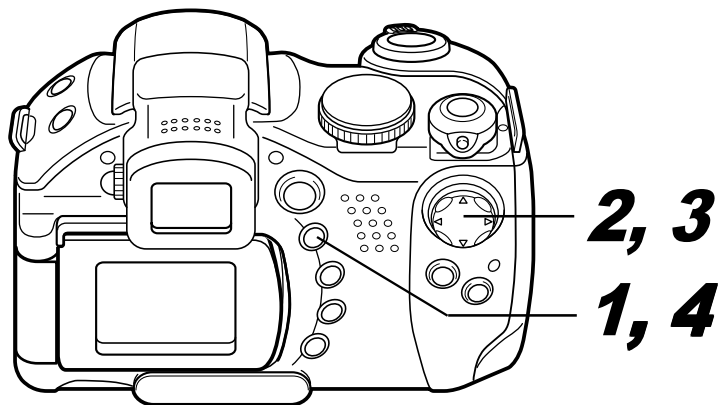
Three ranges -small, medium or large- can be selected. Images are shot with the focus position changing in the following order; current position, backwards and forward.



1 Press the **FUNC.** button.

2 Select * (BKT-Off) using the **▲** or **▼** arrow, select  (Focus-BKT) using the **◀** or **▶** arrow and press the **SET** button.



* The current setting is displayed.

3 Select a range using the **◀** or **▶** arrow.



- Use **▶** to expand the range and **◀** to contract it.
- You can shoot the image right after selecting settings by pressing the shutter button. The menu displays again after the shot, allowing you to change the settings easily.

4 Press the **FUNC.** button and shoot the image with the manual focus (p. 95).

 The Focus-BKT mode is not available when shooting with the flash on. The camera will revert to shooting only one image when the flash is on.

Locking the Exposure Setting (AE Lock)

Mode Dial

P Tv Av

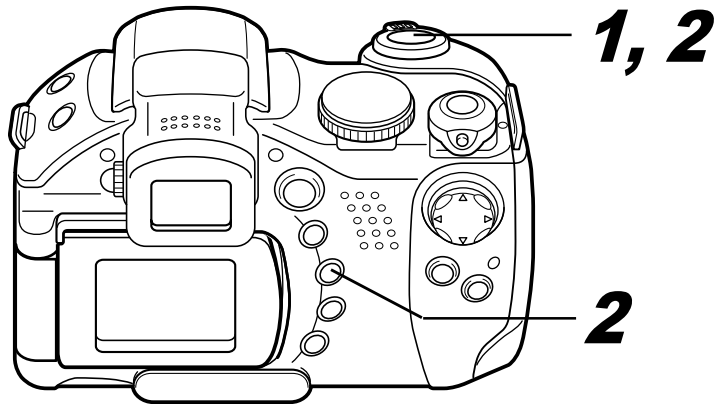

You can set the exposure and focus separately. This is effective when the contrast is too strong between the subject and background or when a subject is backlit.



1 Focus the AF frame or the spot metering frame on the subject on which you wish to lock the exposure setting and press the shutter button halfway.

- See *Selecting and AF Frame* (p. 75)
- See *Switching Between Light Metering Modes* (p. 76)

2 While pressing the shutter button halfway, press the  button.

- The exposure setting locks (AE Lock) and the  icon appears on the LCD monitor (or viewfinder).
- Pressing the  button again cancels the AE lock.



AE lock

3 Recompose the image and shoot.

The camera focuses on the subject in the AF frame.



- ◆ In  mode, AE lock can be set or canceled even during movie recording (p. 56).
- ◆ The automatically selected combinations of shutter speeds and aperture values can be freely changed without altering the exposure with the following procedures.
 1. Turn the mode dial to **P**, **Tv** or **Av**.
 2. Focus on the subject on which you wish to lock the exposure and press the shutter button halfway.

Locking the Flash Exposure Setting (FE Lock)

3. Press the  button.

The exposure setting will lock and the ✖ icon will appear in the LCD monitor (or viewfinder).

4. Press the ◀ or ▶ arrow until the desired shutter speed or aperture value is reached.

5. Recompose the image and shoot. The setting will cancel after the shot is taken.

Mode Dial

P Tv Av

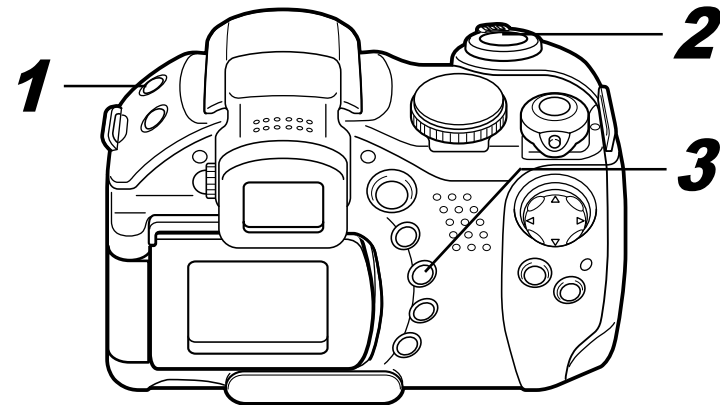

You can obtain the correct exposure regardless of the location of your subject in the composition.



1 Press the  button and set the flash to fire (p. 34).

2 Focus the AF frame or the spot metering frame on the subject on which you wish to lock the flash exposure setting and press the shutter button halfway.

3 While pressing the shutter button halfway, press the button.

- The flash exposure compensation setting locks (FE Lock) and the  icon appears on the LCD monitor (or viewfinder).
- The flash will fire a pre-flash and lock the flash exposure to the required intensity to illuminate the subject.
- Each time you press the  button, the flash exposure locks at the required intensity for that composition.
- Using any button or lever other than the omni selector cancels the FE lock.

4 Recompose the image and shoot.



- ◆ The FE lock function is not available when [Flash Adjust] is set to [Manual].

Switching between Built-in Flash Adjustment Settings

Mode Dial

Tv Av

The built-in flash fires with automatic flash adjustments (except in the **M** mode), but it is possible to set it so that it fires without any adjustments.

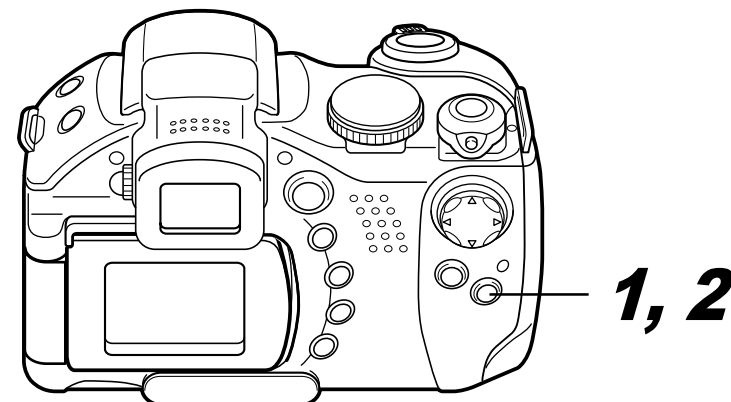

1 Select [Flash Adjust] from the [(Rec.)] menu.

- See *Selecting Menus and Settings* (p. 62).

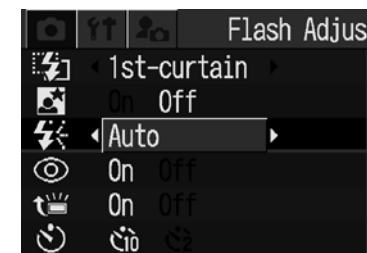

2 Select [Auto] or [Manual] using the or arrow and press the MENU button.

Setting the Flash Adjustment/Flash Output

Mode Dial



*1 When [Flash Adjust] is set to [Manual], flash output settings can be made.

*2 [Flash Output] can be set.

Flash Adjust	<ul style="list-style-type: none"> ● When [Flash Adjust] is set to [Auto], settings can be adjusted in 1/3-stop increments in the range of -2EV to +2EV. ● You can enjoy flash photography with exposure adjustments with the combined use of the camera's exposure compensation function.
Flash Output	<ul style="list-style-type: none"> ● In M mode or when [Flash Adjust] is set to [Manual], the flash output can be controlled in three steps, starting from FULL, when shooting.

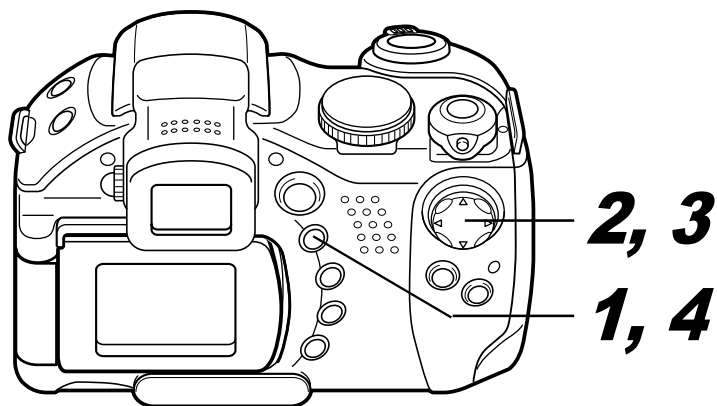

1 Press the FUNC. button.

2 Select (+/- (Flash) or Flash Output) using the ▲ or ▼ arrow.



e.g. [Flash Adjust] set to [Auto]

3 Adjust the compensation using the ◀ or ▶ arrow.



e.g. [Flash Adjust] set to [Manual]

- You can shoot the image right after selecting settings by pressing the shutter button. The menu displays again after the shot, allowing you to change the settings easily.

4 Press the FUNC. button.

Switching the Timing at which the Flash Fires

Mode Dial

P Tv Av M

1st-curtain	The flash fires right after the shutter opens, regardless of the shutter speed. Usually, the 1st-curtain is used when shooting.
2nd-curtain	The flash fires right before the shutter closes, regardless of the shutter speed. Compared with the 1st-curtain, the flash fires later and this allows you to shoot images in which, for example, a car's rear lamps seem to trail off behind.



Image shot with the 1st-curtain setting



Image shot with the 2nd-curtain setting

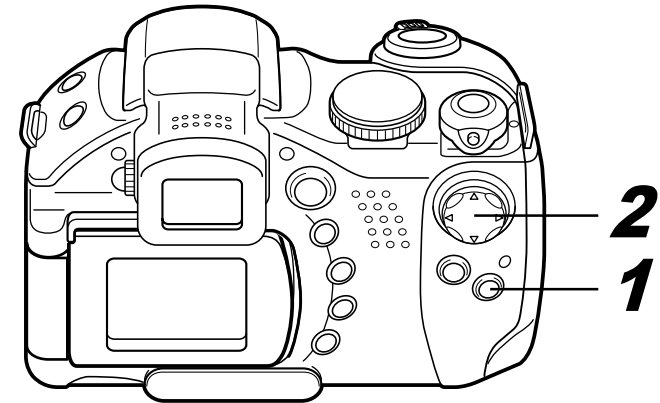

1 From the [] (Rec.) menu, select [**Flash Sync**].

2 Select [**1st-curtain**] or [**2nd-curtain**] using the ◀ or ▶ arrow.

● See *Selecting Menus and Settings* (p. 62).

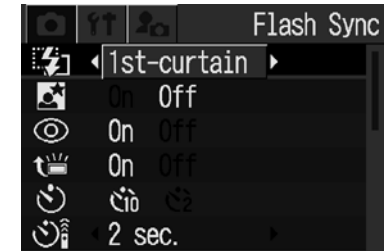

Shooting Images at Set Intervals (Intervalometer)

Mode Dial

P Tv Av M

You can shoot images at a set interval. This function can be used for fixed-point observation of plants and blooming flowers. The shooting interval time can be set from 1 to 60 minutes and 2 to 100 images can be shot.

! Since the camera may shoot continuously for an extended period of time, the use of the Compact Power Adapter CA-PS700 (sold separately) is recommended (p. 143).

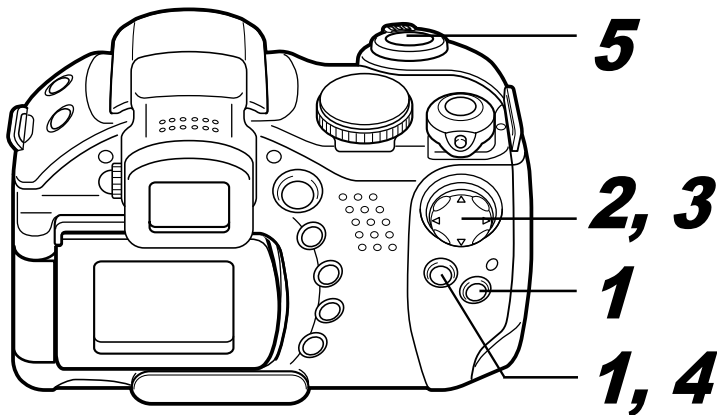

1 Select [Intervalometer] from the [(Rec.)] menu and press the **SET** button.

- See *Selecting Menus and Settings* (p. 62).

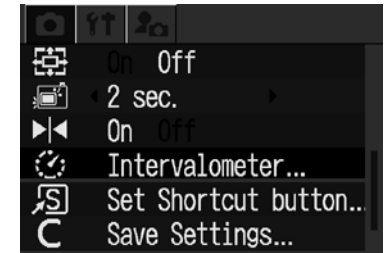

2 Select an interval time using the ◀ or ▶ arrow.

- If you press the ◀ or ▶ arrow continuously, the interval time changes in units of 5 minutes at a time.

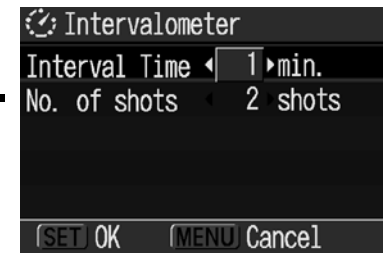

3 Press the ▼ arrow and select the number of shots using the ◀ or ▶ arrow.

- If you press the ◀ or ▶ arrow continuously, the number of shots changes in units of 5 shots at a time.
- The maximum number of shots* is determined according to the CF card's remaining capacity.
- * The maximum number of shots may decrease according to the images shot.

4 Press the SET button.

- The camera exits the menu screen and **Int.** appears at the lower right of the LCD monitor (or viewfinder).

5 Press the shutter button.

- The first image is shot and the interval shooting session starts.
- Once the set number of shots is taken the camera automatically powers down regardless of the power saving function settings.
- If the below operations are accessed while the interval shooting is in process, the interval shooting session will be canceled.
 - Turning the mode dial while the camera is waiting to shoot the next image
 - Pressing the shutter button halfway while the camera is waiting to shoot the next image
 - Opening the CF card slot cover or the battery cover
 - Switching to Playback mode
 - Turning off the power



- Once the interval shooting session is started, all operation buttons become inactive.
- The lens stays extended until the next image is shot.
- Images are not displayed on the LCD monitor (or viewfinder) right after being shot.
- Interval shooting is not available when the date and time are not set.
- Continuous shooting and self-timer shooting are not available.
- AEB mode and the Focus-BKT mode settings cannot be set.

Shooting Problem Subjects for the Autofocus

The autofocus may not work well on the following types of subjects.

- Subjects with extremely low contrast to the surroundings
- Subjects mixing close and far objects
- Subjects with extremely bright objects at the center of the composition
- Subjects that are moving quickly
- Subjects with horizontal stripes

To shoot these subjects, first aim the camera at an object at a similar distance, lock the focus and recompose the image with the desired subject, or use manual focus or AF lock.

Shooting with Focus Lock

Mode Dial

AUTO      **P Tv Av M**

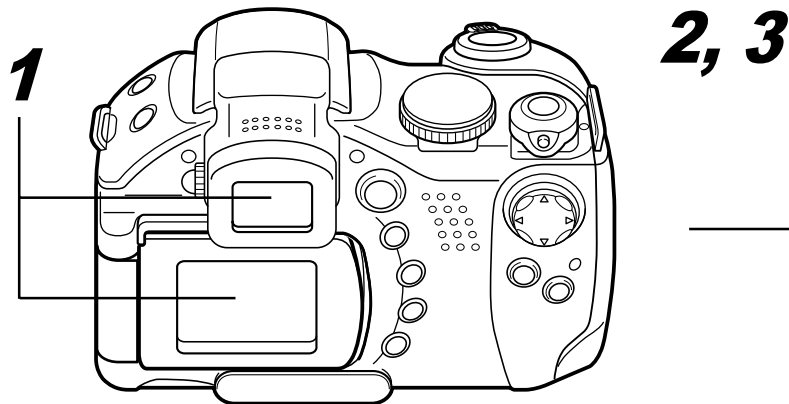

1 Aim the AF frame at an object at a similar distance to the subject you wish to shoot.

2 Press the shutter button halfway to lock the focus.

- The AE setting will also lock when you do this. The exposure may occasionally be incorrect if the difference between the two items is too great. Use AF lock or AE lock when this happens.

3 Keep it pressed while you recompose the image and press the shutter button all the way to shoot the image.

Shooting in AF Lock Mode

Mode Dial

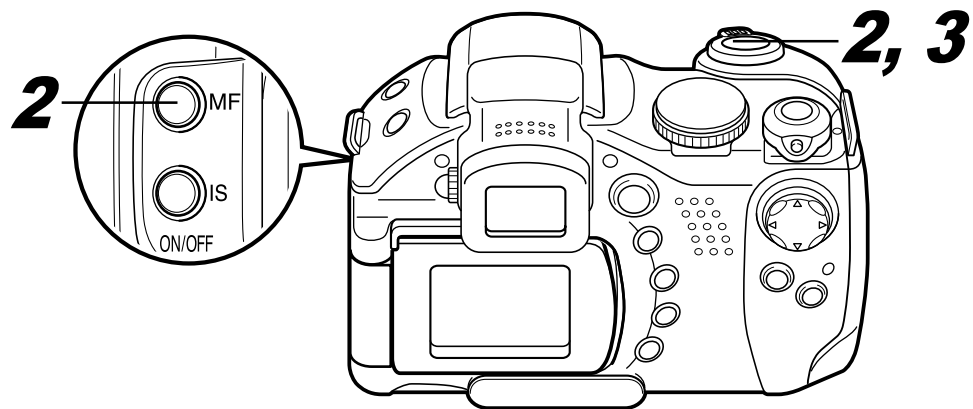

1 Aim the AF frame at an object at a similar distance to the subject you wish to shoot.

2 Press the shutter button halfway and while keeping it pressed, press the MF button.

- MF appears on the LCD monitor (or viewfinder).
- The focus will stay locked even if you release the shutter button and MF button.

- Pressing the MF button a second time cancels the manual focus mode.

3 Recompose the image and press the shutter button all the way to shoot the image.



- ◆ AF lock is convenient because you can let go of the shutter button to recompose the image. In addition, since the focus stays locked to the same position even after the shot is taken, you can immediately shoot the next image with the same focus position.
- ◆ When shooting through glass, get as close as possible to avoid reflection off the glass.
- ◆ In  mode, AF lock can be set or canceled even during movie recording (p. 56).

Shooting in Manual Focus Mode

Mode Dial



The focus can be manually set.

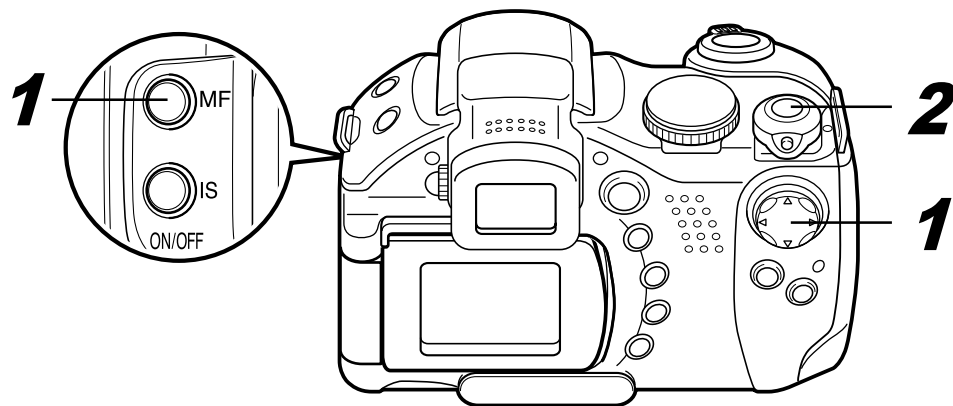

1 Press and hold the MF button, then press the ▲ or ▼ arrow.

- The focus will lock and the MF icon and the MF indicator will appear on the LCD monitor (or viewfinder).



2 Press the shutter button all the way to shoot the image.



Reset the manual focus after the flash pops up.

- When the [] (Rec.) menu's [MF-Point Zoom] is set to [On], if a particular AF frame has been manually selected (p. 75), the portion of the image in that frame will appear magnified.*¹
- * Except in the [], when the digital zoom is activated or a TV is used as the display.
- ¹ Can also be set so that the image displayed is not magnified (p. 65).
- The MF indicator shows approximate figures. Use them as a shooting guideline only.
- Adjust the focus using the ▲ or ▼ arrow until the image appears focused.
- Pressing the MF button a second time cancels the manual focus mode.

Using the Manual Focus in Combination with the Auto Focus

Mode Dial

 P Tv Av M

The camera automatically searches for a more suitable focusing point from the current manually focused location.

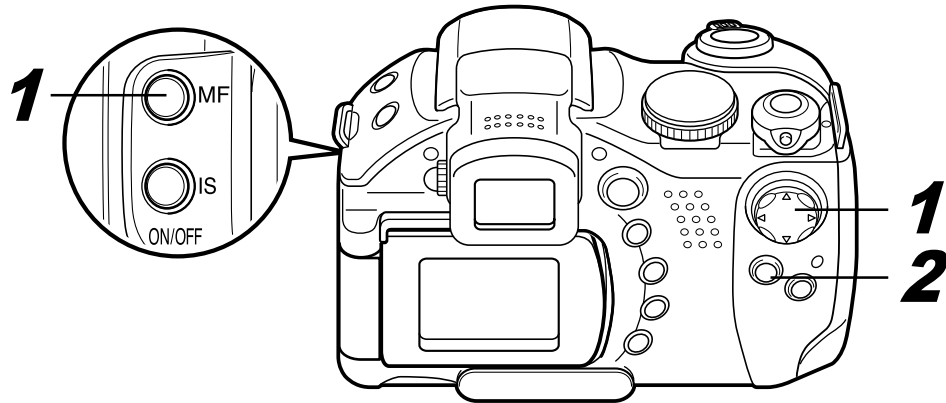



1 Focus the camera with the manual focus.

2 Press the SET button.

- The camera focuses automatically to a more accurate focusing point near the current focusing point.

3 Press the shutter button all the way to shoot the image.

 You cannot change the AF frame setting while focusing manually. Cancel the manual focus mode, then change the AF frame setting.

 You can change the MF indicator displayed distance units (p. 67).

Switching between Focus Settings

Mode Dial

AUTO       **P Tv Av M**

You can switch between focus settings to shoot.

Continuous	The camera is continually focusing on whatever it is aimed even when the shutter button is not pressed, allowing you to shoot without missing opportunities. This is the default setting.
Single	The camera only focuses when the shutter button is pressed halfway, conserving battery power.

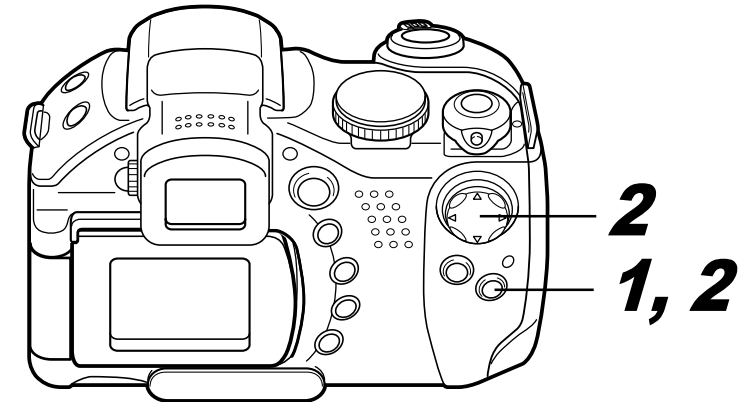

1 In the [] (Rec.) menu, select [AF Mode].

- See *Selecting Menus and Settings* (p. 62).

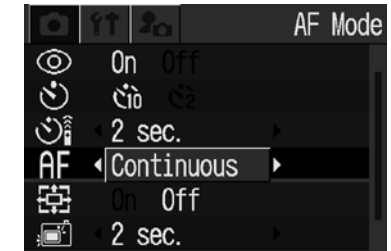

2 Select [Continuous] or [Single] using the ◀ or ▶ arrow and press the MENU button.

C Saving Custom Settings

Mode Dial

P Tv Av M C

You can save frequently used shooting modes and various shooting settings to the **C** (Custom) mode. When necessary, you can then shoot images with previously saved settings by simply turning the mode dial to **C**. Settings that are usually forgotten when the shooting mode is changed or when the power is turned off (such as Continuous Shooting and Self-timer mode) are also remembered.

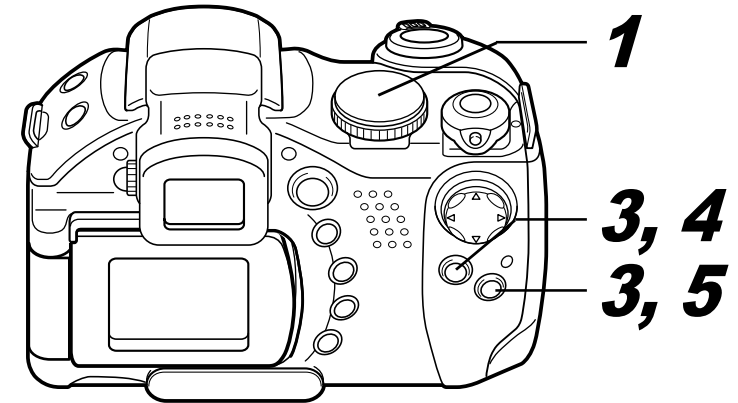

1 Turn the mode dial to P, Tv, Av, M or C.

- When you wish to re-save partially modified settings (except shooting mode) that were previously saved in the **C** mode, select **C**.

2 Set the setting contents you wish to save.

Settings that can be saved to the **C** mode

- Shooting mode (**P**, **Tv**, **Av**, **M**)
- Items that can be set in **P**, **Tv**, **Av** and **M** modes (p. 166)
- Shooting menu settings
- Zoom location
- Manual focus location

3 Select [Save Settings] from the [📷(Rec.)] menu and press the SET button.

- See *Selecting Menus and Settings* (p. 62).

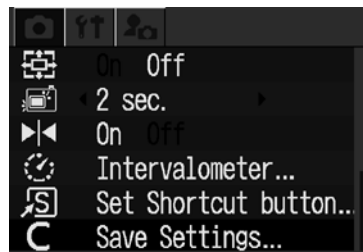

4 Select [OK] and press the SET button.

5 Press the MENU button.



- ♦ The setting contents do not influence other shooting modes.
- ♦ Saved settings can be reset (p. 68).

Images can be rotated 90° and 270° clockwise on the LCD monitor.

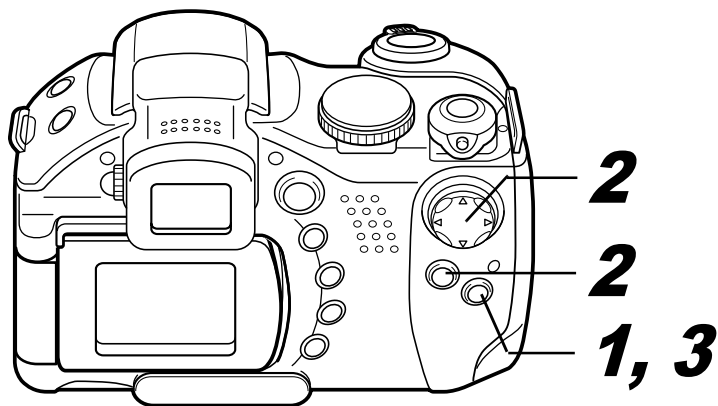

1 Select [Rotate] from the [Play] menu and press the SET button.

- See *Selecting Menus and Settings* (p. 62).

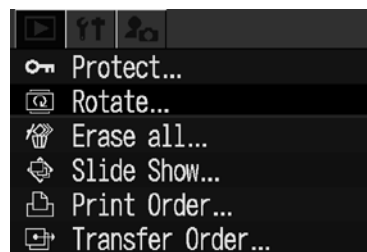

2 Select an image you want to rotate using the ◀ or ▶ arrow and press the SET button.



- The image cycles to the next orientation (90° → 270° → original) each time the SET button is pressed.

3 Press the MENU button.

- The Play menu appears again. Press the MENU button again to close the menu.



- Movies cannot be rotated.
- When images are downloaded to a computer, the orientation of images rotated by the camera will depend upon the software used to download the images.



- ◆ Images can be magnified when rotated (p. 40).
- ◆ Images taken vertically with the auto rotate function (p. 108) set to [On] will automatically be rotated to the vertical position when viewed on the LCD monitor (or viewfinder).

🎤 Attaching Sound Memos to Images

In Playback mode (including single image playback, index playback, magnified playback and the review immediately after shooting in Shooting mode) you can attach sound memos (up to 60 seconds) to an image. The sound data is saved in WAVE format.

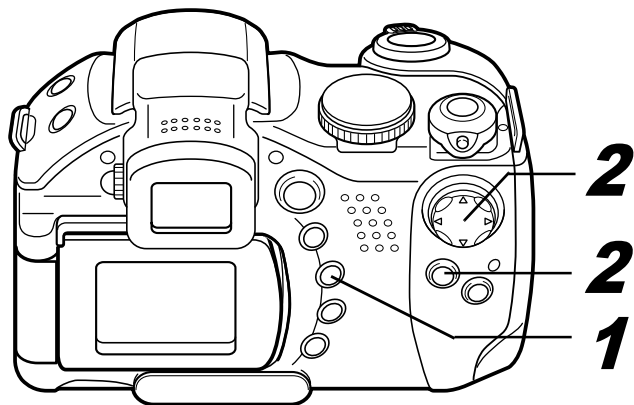

1 Press the 🎤 button while playing back images.

- The Sound Memo panel appears.

2 Select using the ◀ or ▶ arrow and press the SET button.



Sound Memo Panel

- The recording starts and the elapsed time is displayed. Speak towards the microphone of the camera.
- To stop recording, press the **SET** button. To restart recording, press the **SET** button again.
- You can add as many sound memos as you like until their total time reaches 60 seconds.

Playing back the Sound Memos

- Select . Images with sound memos are displayed with the 🎵 mark (they do not display in No Information display mode). To stop playback, press the **SET** button. To restart playback, press the **SET** button again. You can adjust the volume using the ▲ or ▼ arrow.

Erasing the Sound Memos

- Check that 🎵 is displayed and select .

Exiting the Sound Memos Menu

- Press the 🎤 button.

Automated Playback (Slide Show)



- You cannot attach sound memos to movies.
- You cannot record or playback sound notes for images that already have an incompatible sound file attached. If you attempt to record or play such images, the "Incompatible WAVE format" message will display. Incompatible sound files can be deleted with this camera.
- Sound memos for protected images cannot be erased (p. 106).



The volume can be adjusted in the Set up menu (p. 66). If you set [Mute] to [On] in the Set up menu, no sound is reproduced, however, you can resume the sound and adjust the volume by pressing the ▲ or ▼ arrow.

Slide show image settings are based on DPOF standards (p. 119).

Starting a Slide Show

All images, or a selection of images, can be displayed one-by-one in an automated slide show.

All Images	Plays all the images on the CF card in order
Slide Show 1 - 3	Plays the images selected for each show in order (p. 103)

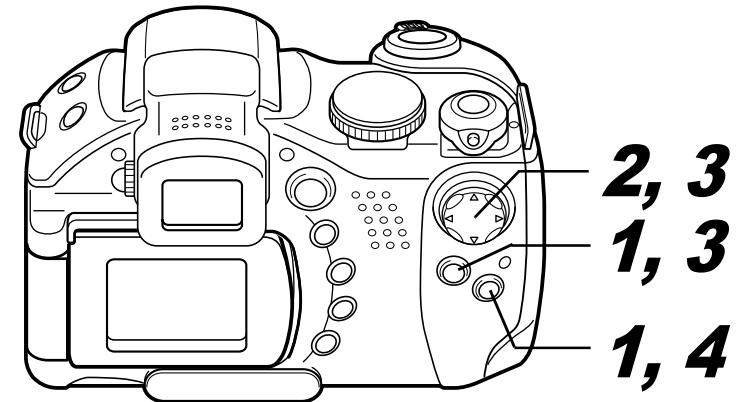

1 In the [] (Play) menu, select [Slide Show] and press the SET button.

- See *Selecting Menus and Settings* (p. 62).

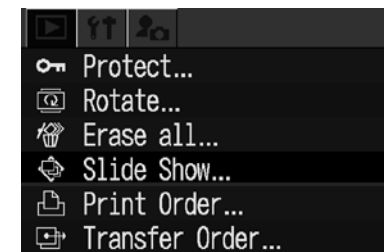

2 Select [Program] using the ▲ or ▼ arrow and select between [All images] or one of [Show 1]-[Show 3] using the ◀ or ▶ arrow.



3 Select [Start] using the ▲ or ▼ arrow and press the SET button.

The show will start and automatically stop when the show is done.

Pausing and Resuming a Slide Show

- Press the **SET** button to pause the show. Press it again to resume.

Fast Forward/Rewinding a Slide Show

- Use the ◀ or ▶ arrow to move to the previous or next image.

Stopping a Slide Show

- Press the **MENU** button during a slide show to stop it and display the slide show menu.

4 When the slide show is over, press the **MENU** button.

The slide show menu appears again. Press the **MENU** button again to close the menu.



- ◆ Movie images play for the length of time that they were recorded regardless of the time set in the slide show settings.
- ◆ The power saving function is disabled while a slide show plays on the camera (p. 107).

Selecting Images for Slide Shows

You can mark images for inclusion in slide shows 1-3. Up to 998 images may be marked per slide show. Images display in the order of their selection.

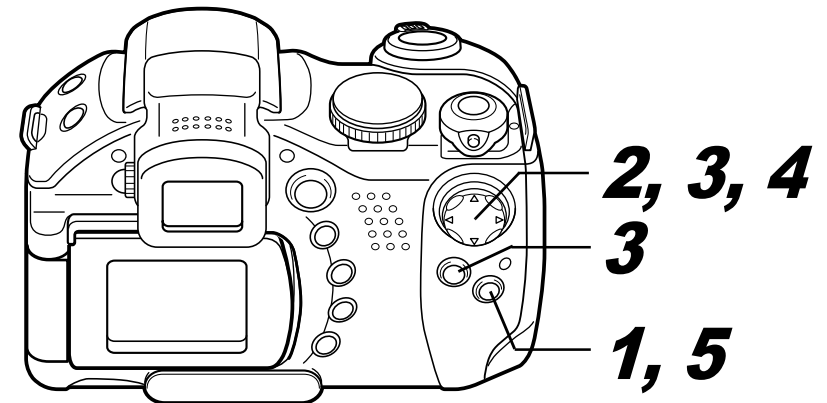

1 Display the slide show menu (p. 102).

2 Select [Program] using the ▲ or ▼ arrow and select [Show 1], [Show 2] or [Show 3] using the ◀ or ▶ arrow.

- A checkmark (✓) will appear beside a show already containing images.

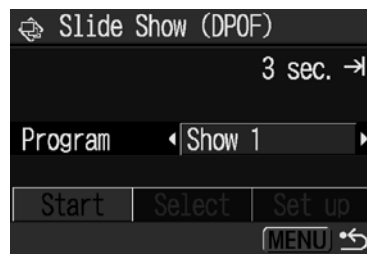

3 Choose [Select] using the ▼ and ◀ or ▶ arrows and press the SET button.

4 Mark images to include in the show.

Single Image Playback

- Move between images using the ◀ or ▶ arrow and mark or remove marks from images using the ▲ or ▼ arrow.
- The selection number and a check mark (✓) appear at the bottom of selected images.



Index Playback

- Turn the zoom lever toward Q to switch to index playback (3 images).
- Select an image using the ◀ or ▶ arrow and mark or remove marks from images using the ▲ or ▼ arrow.
- The selection number and a check mark (✓) appear at the bottom of selected images.
- After you press the **SET** button, you can select all the images by selecting [Mark all] using the ▲ or ▼ arrow and pressing the **SET** button again. You can deselect all the images by selecting [Clear all].
- You can select images using the ◀ or ▶ arrow and change the settings using the ▲ or ▼ arrow after [Mark all] or [Clear all] has been selected.



5 Press the MENU button.

- The image selection screen will close.

Adjusting the Play Time and Repeat Settings

Play Time	Sets the duration that each image in a slide show is displayed. The options are any one of 3-10 seconds, 15 seconds, 30 seconds and Manual.
Repeat	Sets whether the slide show stops when all the slides have been displayed or continues to display until stopped.

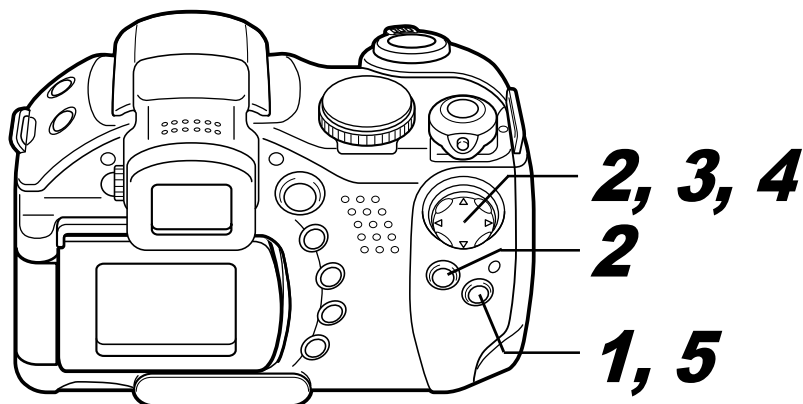

1 Display the slide show menu (p. 102).

2 Select [Set up] using the ◀ or ▶ arrow and press the SET button.



3 Select [Play Time] or [Repeat] using the ▲ or ▼ arrow.

4 Select a setting using the ◀ or ▶ arrow.

Play time

- Select a play time.

Repeat

- Select [On] or [Off].

5 Press the MENU button.

The set up menu closes.



- ◆ The display interval may vary somewhat for some images.
- ◆ Slide shows can be easily edited on a computer with the supplied software (*ZoomBrowser EX* or *ImageBrowser*).



Protecting Images

You can protect important images from accidental erasure.

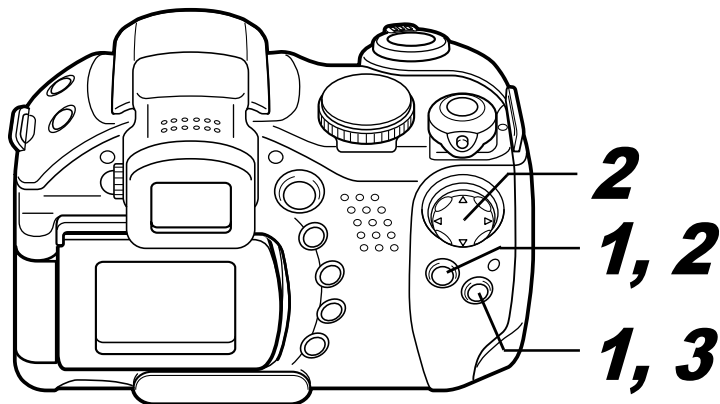

1 In the [▶] (Play) menu, select [Protect] and press the SET button.

- See *Selecting Menus and Settings* (p. 62).

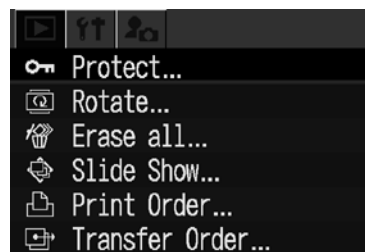

2 Select an image you want to protect using the ◀ or ▶ arrow and press the SET button.



- The  icon appears on protected images.
- To remove the protection, press the SET button again (in protection mode).
- You can make the selection of images easier by toggling between single image playback and index playback with the zoom lever.

3 Press the MENU button.

The protect window closes.

 Please note that formatting (initializing) a CF card erases all data, including protected images (p. 18) and other file types. Please check the contents of a CF card before formatting it.

This camera is equipped with a power saving function. Depending on the power saving setting, the camera may power down or the LCD monitor (or viewfinder) may go off automatically.

● Auto Power Down

[On]: ● **Shooting mode**
Powers down approximately 3 minutes after the last time a camera control is accessed. The LCD monitor (or viewfinder) automatically shuts off approximately 1 minute*¹ after the last time a camera control is accessed even if [Auto Power Down] is set to [Off]. Press any button except the **OFF** button to turn the LCD monitor (or viewfinder) back on.

*¹ This time can be changed (p. 108).

● **Playback mode**
Powers down approximately 5 minutes after the last time a control is accessed on the camera.

● **Printer Connection mode**
Powers down approximately 5 minutes after the last time a control is accessed on the camera or something is printed on the printer.

[Off]: The power saving function does not activate.

● Display Off (Shooting Mode Only)

The LCD monitor (or viewfinder) shuts off after a specified period of time elapses and no camera control is accessed. The following time settings can be selected: 10 sec./20 sec./30 sec./1 min.*²/2 min./3 min.

*² Default setting

When the Auto Power Down Function Activates

Turn the power on again.

Playback/Printer Connection mode: Turn the mode lever to the right again to power the camera.

When the Display Off Function Activates

The LCD monitor (or viewfinder) display turns back on if any button other than the shutter button is pressed.



- ◆ Please note that the camera continues to consume a minimal amount of power even when the power saving function shuts it down.
- ◆ The power saving function is disabled while a slide show plays on the camera or during a computer connection (p. 102, 115).
- ◆ You can turn off the power saving function in the Set up menu (p. 66).

Setting the Auto Rotate Function

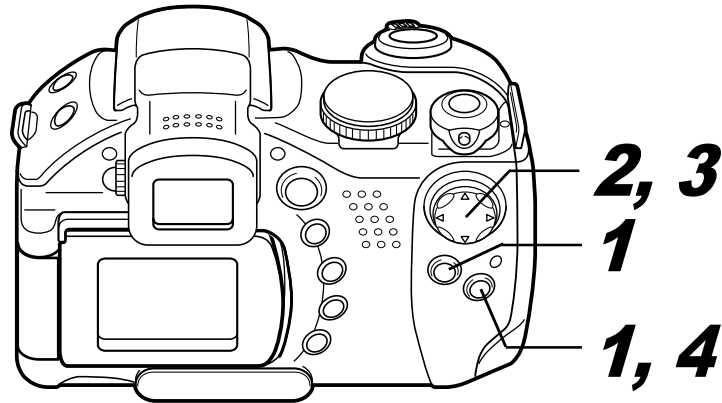

1 Select [Power Saving] in the [ⓘ (Set up)] menu and press the SET button.

- See *Selecting Menus and Settings* (p. 62).

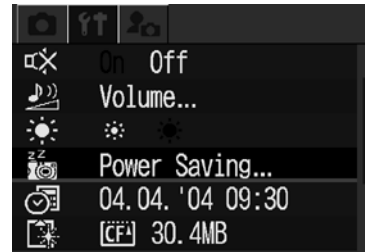

2 Select [Auto Power Down] using the ▲ or ▼ arrow and select [On] or [Off] using the ◀ or ▶ arrow.

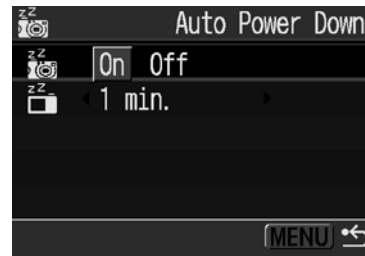

3 Select [Display Off] using the ▲ or ▼ arrow and select a time using the ◀ or ▶ arrow.

4 Press the MENU button.

Mode Dial



This camera is equipped with an Intelligent Orientation sensor that detects the orientation of an image shot with the camera on end and automatically rotates it to the correct viewing orientation in the display. You can set this function on/off.

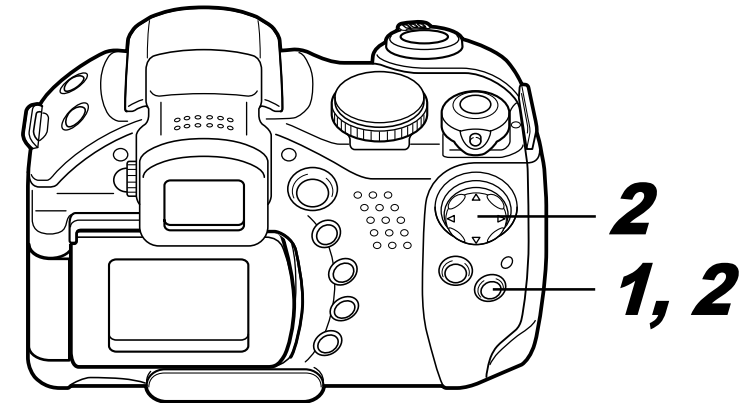

1 Select [Auto Rotate] in the [ⓘ (Set up)] menu.

- See *Selecting Menus and Settings* (p. 62).



2 Select [On] using the ◀ or ▶ arrow and press the MENU button.

- When this function is On, an icon showing the orientation of the camera appears at the upper right corner of the LCD monitor (or viewfinder) if it is set to Information View.

 : Normal

 : Camera on right end

 : Camera on left end



● This function may not operate correctly when the camera is pointed straight up or down. Check that the correct camera orientation icon (e.g. ) is displayed and if it is not, then set the Auto Rotate function to Off.

● Even if the Auto Rotate function is set to On, the orientation of images downloaded to a computer will depend upon the software used to download the images.



- ◆ When the camera is held on end to shoot, the Intelligent Orientation sensor judges the upper end to be "up" and the lower end to be "down". It then regulates the optimal white balance and exposure for vertical photography. This function operates regardless of the On/Off status of the Auto Rotate function.
- ◆ When changing the camera's orientation between the horizontal and vertical positions, you may hear noise coming from the orientation detection mechanism. This is not a malfunction.

Resetting the File Numbers

You can select the way file numbers are assigned.

On	The file numbers are reset to the start (100-001) each time a new CF card is inserted. New images recorded on CF cards with existing files are assigned the next available number.
Off	The file number of the last image to be shot is memorized so that images recorded to a new CF card start from the next number.

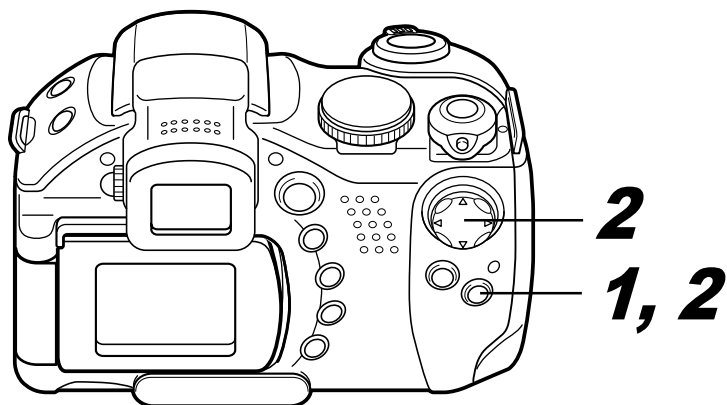

1 In the [M] (Set up) menu, select [File No. Reset].

- See *Selecting Menus and Settings* (p. 62).

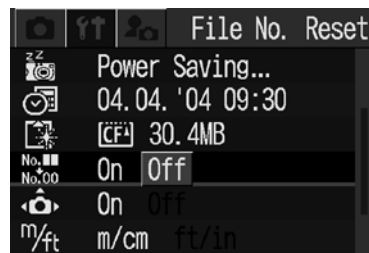

2 Select [On] or [Off] using the ◀ or ▶ arrow and press the MENU button.



- ♦ Setting the [File No. Reset] to [Off] is useful for avoiding file name duplication when images are downloaded to a computer.
- ♦ See *Managing Image Files* (p. 155).

Customizing the Camera (My Camera Settings)

My Camera allows you to customize the start-up image and start-up, shutter, operation and self-timer sounds. Each menu item has three choices.

Changing My Camera Settings

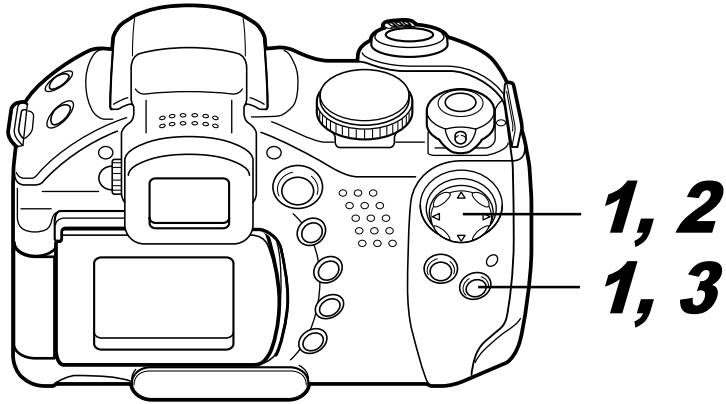

1 Press the MENU button and press the ► arrow twice.

The [My Camera] menu appears.

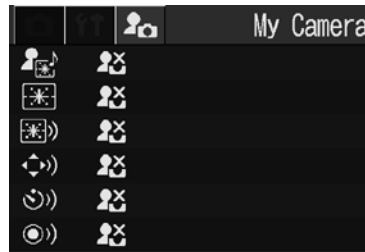

2 Select a menu item using the ▲ or ▼ arrow, then select setting content using the ◀ or ▶ arrow.

[Off] icon : Off

[1] icon : General

[2] icon : Science fiction theme

[3] icon : Animal theme

- The contents of the [2] and [3] options can be changed (p. 67).

3 Press the MENU button.



The menu closes and settings are activated.

- In Shooting mode, the menu can be closed by pressing the shutter button halfway.



- ♦ If you select [Theme] in Step 2, you can select a consistent theme for each of the My Camera settings.
- ♦ If [Mute] in the [1] (Set up) menu is set to [On], no sound is reproduced except for the error warning signal regardless of the selected My Camera settings. The Start-up image displays (p. 67).

Registering My Camera Settings

This function registers new contents to the  and  options.

Images recorded onto the CF card and newly recorded sounds can be added to the camera. You can also use the supplied software to upload your computer's images and sounds to the camera. The following menu items can be saved to the camera.

- Start-up Image
- Start-up Sound
- Operation Sound
- Selftimer Sound
- Shutter Sound

The CF card images and sounds can be registered to the camera with the following procedures.

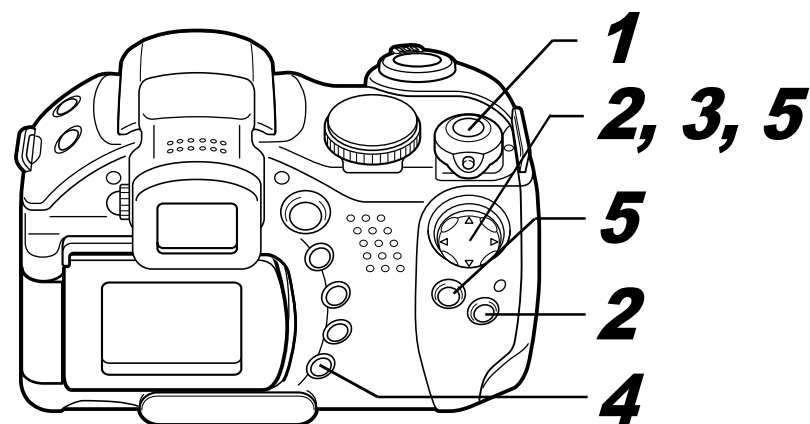





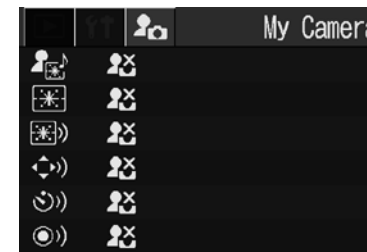

1 Turn the mode lever toward  (Playback).

2 Press the MENU button and press the  arrow twice.

The [ (My Camera)] menu appears.



3 Select the menu item you wish to register using the  or  arrow and select  or  using the  or  arrow.

DISPLAY  appears.

4 Press the DISPLAY button.

- The start-up image screen or the sound recording menu appears

Registering a Start-up Image

- Select the image you wish to register using the ◀ or ▶ arrow and press the **SET** button.



Registering Start-up, Operation, Self-timer and Shutter Sounds

- Select (Record) using the ◀ or ▶ arrow and press the **SET** button.
- Recording will start and automatically stop when the time is exceeded.



Start-up Sound: 1 sec. Operation Sound: 0.3 sec.
Self-timer Sound: 2 sec. Shutter Sound: 0.3 sec.

- Select (Register) and press the **SET** button.

5 Select [OK] using the ◀ or ▶ arrow and press the SET button.



- Sounds recorded using the Sound Memo function (p. 101) and movies cannot be registered as My Camera settings.
- When you register new My Camera settings, the previously registered settings are erased.

File Format of My Camera Settings

My Camera settings should conform to the below file formats. However, CF card images shot with this camera can be registered as My Camera settings regardless of the below formats.





● Start-up Image

- Recording image format JPEG (Base line JPEG)
- Sampling rate 4:2:0 or 4:2:2
- Image size 320 x 240 pixels
- File size 20 KB or less

● Start-up Sound, Operation Sound, Selftimer Sound and Shutter Sound

- Recording format WAVE (monaural)
- Quantization bit 8 bit
- Sampling frequency 11.025 kHz and 8.000 kHz

- Recording time

	11.025 kHz	8.000 kHz
 Start-up Sound	1.0 sec. or less	1.3 sec. or less
 Operation Sound	0.3 sec. or less	0.4 sec. or less
 Selftimer Sound	2.0 sec. or less	2.0 sec. or less
 Shutter Sound	0.3 sec. or less	0.4 sec. or less

Any file format other than those described above cannot be used with this camera.

An example of this function is to record "Say cheese" as a self-timer sound so the camera will play back this sound 2 seconds before the photo is taken. You could also record cheerful music to bring out the natural smiles of your subjects, or so they can strike a pose fitting the music. In these ways, you can customize your camera by creating and adding new My Camera settings.

See the supplied *Canon Digital Camera Software Starter Guide Disk* for more information on creating and adding My Camera files.

Download images taken with the camera to a computer in one of the following ways:

Connect the camera to a computer with the USB cable

You can then download images directly from the camera to a computer.

Directly from the CF card

Using a card adapter or a card reader, you can download images directly from the CF card.

After the software is installed, you can use it to easily download images and print them or send them by e-mail.

You must install the software and driver bundled on the supplied Canon Digital Camera Solution Disk onto your computer if you are using any of the following operation systems:

- Windows 98 (including Second Edition)/
Windows 2000/Windows Me
- Mac OS 9.0 - 9.2



- ◆ It is recommended to power the camera with the separately sold Compact Power Adapter CA-PS700 when connected to a computer (p. 143).
- ◆ All procedures performed with a connection to a USB 2.0 compliant board are not guaranteed.

Refer to the *Canon Digital Camera Software Starter Guide Disk* in the following circumstances

- You connected the camera to the computer before installing the driver and software and the camera is not being recognized by the computer (see the *Troubleshooting* section of the *Canon Digital Camera Software Starter Guide Disk*)
- You want to find out about the computer system requirements or about driver and software installation procedures.
- You want to find out about how to operate the camera/computer after the connection is made.

1 Install the driver and the software applications bundled on the Canon Digital Camera Solution Disk.

2 Connect the supplied interface cable to the computer's USB port and the camera's DIGITAL terminal.

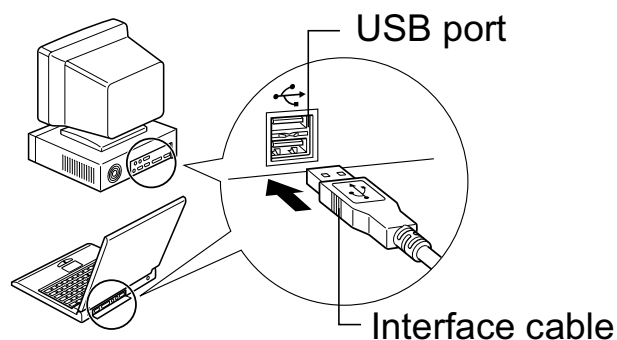

DIGITAL Terminal

- ① Open the terminal cover with your fingernail.
- ② Hold the USB connector so the  side is up, then insert it into the **DIGITAL** terminal securely.

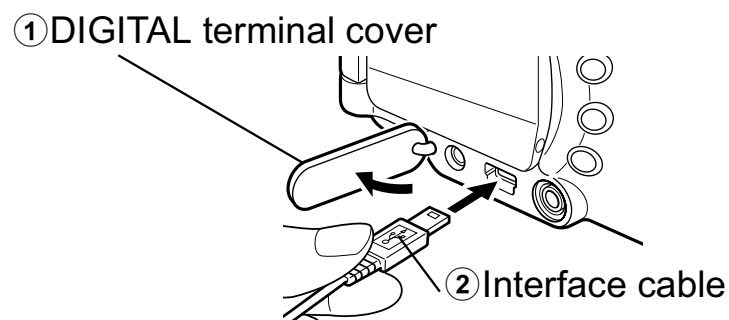

- To disconnect the cable from the camera: Hold the cable connector firmly at both sides and pull it straight out.

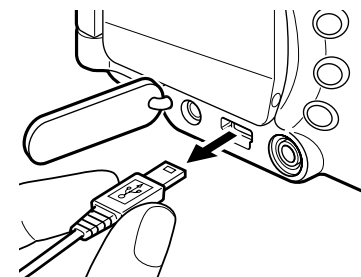

- You do not need to turn off the computer or camera when making a USB connection.
- Please refer to your computer manual for information regarding the location of the USB port.
- The camera's LCD monitor (or viewfinder) will blank out when the connection to the computer is complete and the power/mode indicator will light yellow. .

Downloading Images without Installing the Software (Windows XP and Mac OS X (v10.1 or v10.2) only)

If you are using Windows XP or Mac OS X (v10.1 or v10.2), you can use the software distributed with these operating systems to download images (JPEG format only) without installing the software bundled on the Canon Digital Camera Solution Disk. This is useful for downloading images to a computer in which the software is not installed.

However, please note that there are certain limitations to downloading images with this method. For more details, please refer to the supplied *For Windows® XP and Mac OS X Users* leaflet.

1. Connect the supplied interface cable to the computer's USB port and the camera's DIGITAL terminal. (Refer to Step 2 of page 116).
2. Follow the onscreen instructions to download the images.

Mac OS X (v10.1 or v10.2)

When downloading images that have sound memos with iPhoto, the sound memo file will not be downloaded. In addition, please note if [Erase camera contents after transfer] is selected when you download images, sound memo files will also be deleted.

Downloading Directly from a CF Card

1 Eject the CF card from the camera, and insert it into a CF card reader connected to the computer.

- If you are using a PC card reader or PC card slot in your computer, first insert the CF card into a PC card adapter (sold separately) ①, and then insert the PC card adapter into the computer's PC card reader or PC card slot ②.

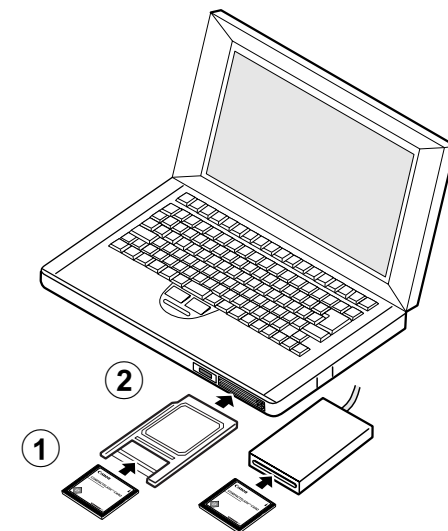

2 Double-click the icon of the drive with the CF card.

- Depending on the OS, the CF card screen may automatically open.

3 Copy images from the card into a folder of your choice on the hard disk.

- The images are stored in the [xxxCANON] folders located under the [DCIM] folder (where xxx is a three-digit number from 100 to 998) (p. 155).

Viewing Images on a TV Set

A video-compatible television connected via the supplied AV cable AVC-DC300 can be used to view images as you shoot or play back them.

- 1 Turn off the camera (p. 19) and the TV.**
- 2 Attach the AV cable to the A/V OUT terminal on the camera.**

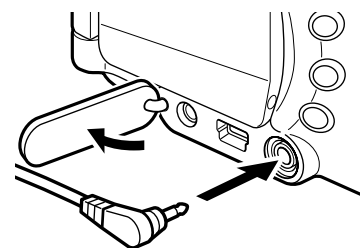

- 3 Plug the other ends of the AV cable to the video in and audio in jacks on the TV.**

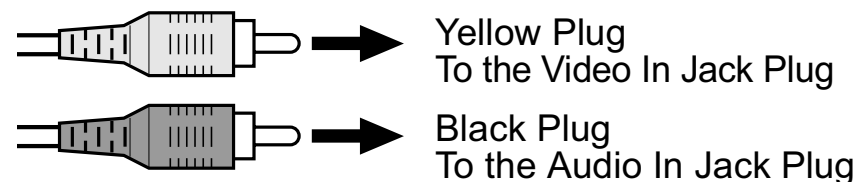

4 Turn on the TV and switch it to Video mode.

5 Power the camera into Shooting mode or Playback mode (p. 19).

- The image will appear on the TV. Shoot or play back images as usual.



- ◆ No image will appear on the LCD monitor (or viewfinder) when the camera is connected to a TV monitor.
- ◆ The video output signal can be switched (NTSC or PAL) to accommodate different regional standards. The default setting will vary between regions.
NTSC:Japan, U.S.A., Canada, Taiwan, etc.
PAL:Europe, Asia (excluding Taiwan), Oceania, etc.
If an incorrect vide system is set, the output image will not display properly.
- ◆ If the TV is a stereo model, you can plug the audio plug into either the left or right Audio In jack. Please refer to the TV's manual for details.
- ◆ A TV set cannot be used in the  (Stitch Assist) mode.

About Printing

There are two ways of printing images shot with this camera.

- You can easily print images stored in the CF card by connecting the camera to a direct print compatible printer*¹ with a cable and operating the camera buttons.
- You can specify the images on your CF card you want to print and how many copies you want (DPOF*² Print Settings), and then take the CF card to a participating photo lab that supports DPOF to have them printed out later.

*¹ This camera complies with the industry standard *PictBridge*, therefore, you can connect the camera to non-Canon *PictBridge* compliant printers and print images.

*² Digital Print Order Format

This manual explains the DPOF print settings. For information on how to print images, refer to the *Direct Print User Guide* supplied with the camera. Also, refer to your printer's manual.

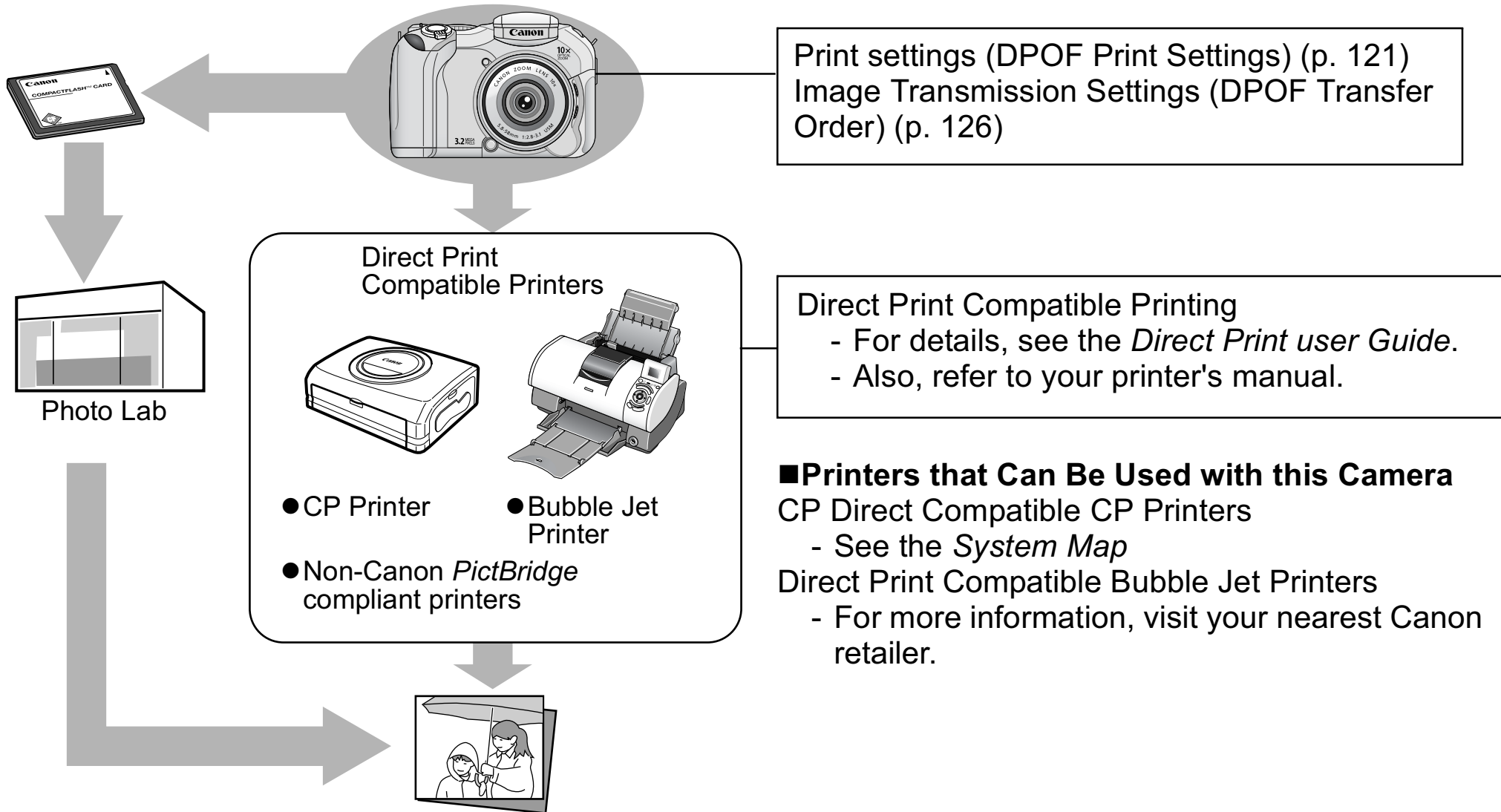

Print Settings (DPOF Print Settings)

You can select images on a CF card for printing and specify the number of print copies in advance using the camera. This is extremely convenient for sending the images to a photo developing service or for printing on a direct print function compatible printer. Refer to the *Direct Print User Guide* for instructions on how to select print settings from the printer.



- The  mark may appear on images that have had print marks set by another DPOF compliant camera. These settings will be overwritten by any print marks set by your camera.
- The output of some digital printers or photo lab services may not reflect the specified print settings.
- Print settings cannot be set for movies.

Selecting Images for Printing

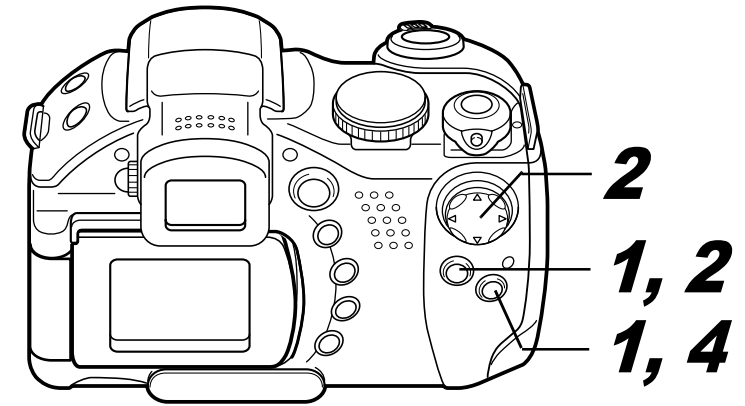

1 In the [ (Play)] menu, select [**Print Order**] and press the **SET** button.

- See *Selecting Menus and Settings* (p. 62).

2 Select [**Order**] using the **◀** or **▶** arrow and press the **SET** button.

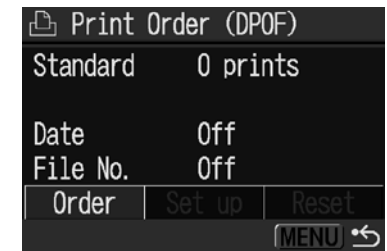
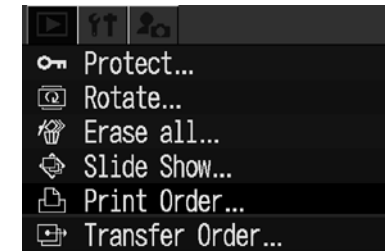

3 Select images for printing.

Single Images

- When the print type (p. 123) is set to [Standard] or [Both], select an image using the ◀ or ▶ arrow. You can set the number of copies (up to 99) to be printed using the ▲ or ▼ arrow.
- When the print type (p. 123) is set to [Index], select an image using the ◀ or ▶ arrow and mark or remove marks from images using the ▲ or ▼ arrow. A check mark appears on the marked image.
- You can use the same procedures to select images in index playback (3 images). Turn the zoom lever toward Q to switch between single image playback and index playback.



All the Images on the CF Card

- Turn the zoom lever toward Q to switch to index playback (3 images).
- You can set one copy of each image to print by pressing the **SET** button, then selecting [Mark all] using the ▲ or ▼ arrow, and pressing the **SET** button again.
- When the print type is set to [Standard] or [Both], the setting for the number of print copies can be changed for each image. When [Index] is selected, the print settings can be deleted. For the instructions on changing settings, please reread Step 3 from the beginning.
- You can cancel all the settings by selecting [Clear all].
- After having marked all images or cleared all images, you can choose a specific image and select settings.



Number of copies

4 Press the MENU button.

The selection mode will turn off and the Print Order menu will reappear.







- ◆ Images are printed in order from oldest to newest by the shooting date.
- ◆ A maximum of 998 images can be marked per CF card.
- ◆ When [Print Type] is set to [Both], the number of copies can be set. When it is set to [Index], the number of copies cannot be set (only one copy will be printed).
- ◆ Print settings can also be assigned to images with the supplied software programs (ZoomBrowser EX or ImageBrowser) on a computer.

Setting the Print Style

Always select a print style after having selected the image you wish to print.

The following print settings can be selected.

Print Type	 Standard	Prints one image per page
	 Index	Prints the selected images together at a reduced size in an index format
	  Both	Prints the images in both the standard and index formats
Date		Adds the date to the print
File No.		Adds the file number to the print

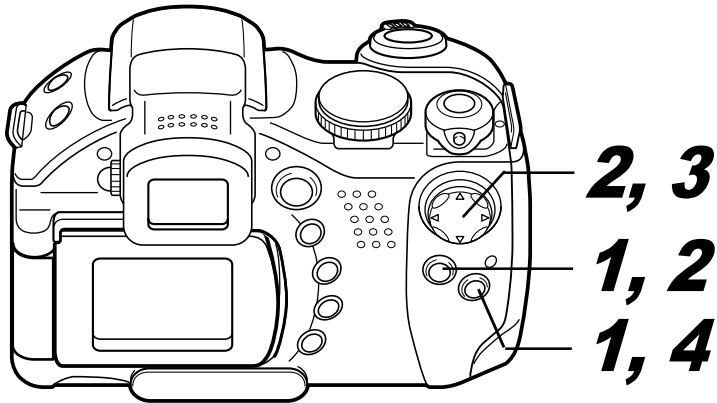

1 In the [] (Play) menu, select [Print Order] and press the SET button.

- See *Selecting Menus and Settings* (p. 62).

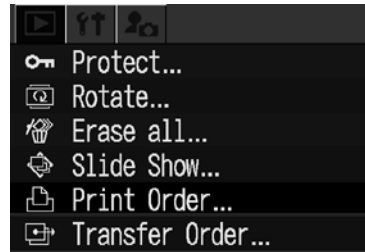

2 Select [Set up] using the ◀ or ▶ arrow and press the SET button.

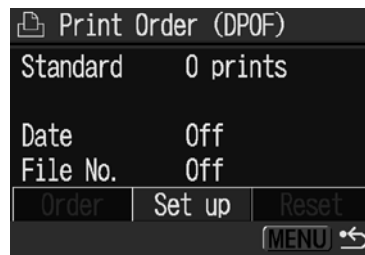

3 Select [Print Type], [Date] or [File No.] using the ▲ or ▼ arrow and select settings using the ◀ or ▶ arrow.

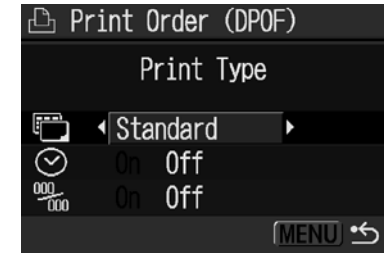

Print Type

- Select [Standard], [Index] or [Both].

Date

- Select [On] or [Off].

File No.

- Select [On] or [Off].

4 Press the MENU button.

The set up menu will close and the Print Order menu will reappear.

- When [Print Type] is set to [Index], the [Date] and [File No.] cannot be set to [On] at the same time.
- With CP printers, if [Print Type] is set to [Both], both [Date] and [File No.] can be set to [On], however, only the file number is printed for the index print.



The date prints as the date and time in the format specified in the Set Date/Time menu (p. 21).

Resetting the Print Settings

The print settings can all be removed at once. The print type is reset to [Standard] and the date and file number options are set to [Off].

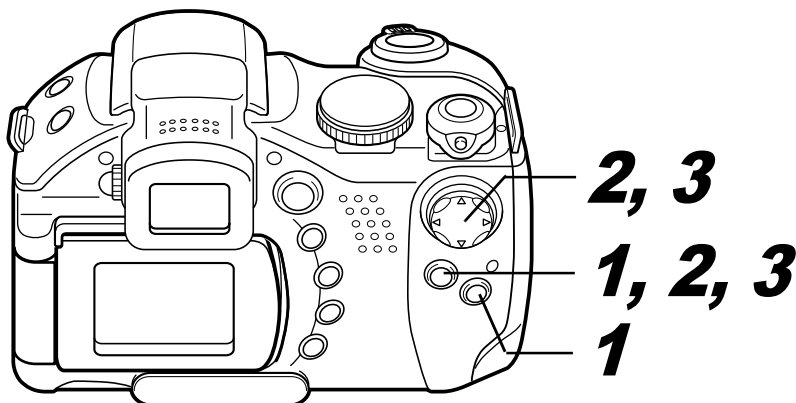

1 In the [(Play)] menu, select [Print Order] and press the SET button.

- See *Selecting Menus and Settings* (p. 62).

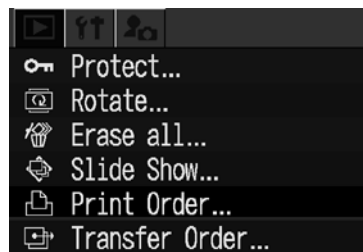

2 Select [Reset] using the ◀ or ▶ arrow and press the SET button.

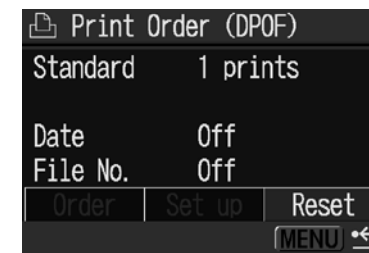

3 Select [OK] using the ◀ or ▶ arrow and press the SET button.

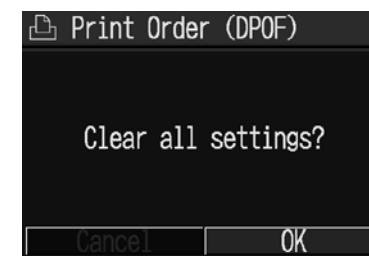

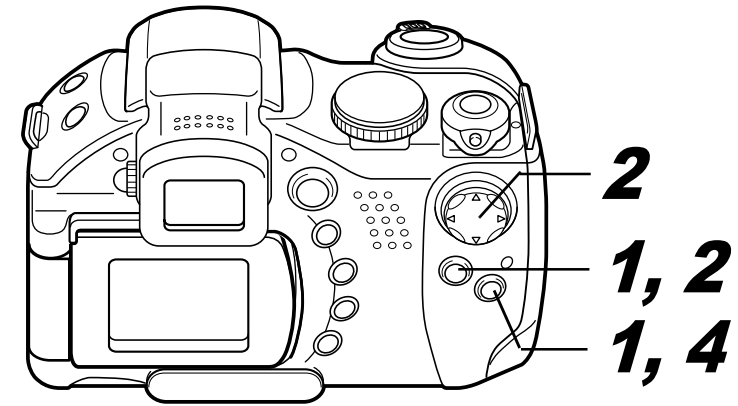



Image Transmission Settings (DPOF Transfer Order)

You can use the camera to specify settings for images before downloading to a computer. Refer to the *Canon Digital Camera Software Starter Guide Disk* for instructions on how to transfer images to your computer. You cannot use this function to transfer several images at once on Mac OS X computers. The settings used on the camera comply with the Digital Print Order Format (DPOF) standards.

 The  mark may appear on images that have had transfer marks set by another DPOF compliant camera. These settings will be overwritten by any transfer marks set by your camera.



Selecting Images for Transferring

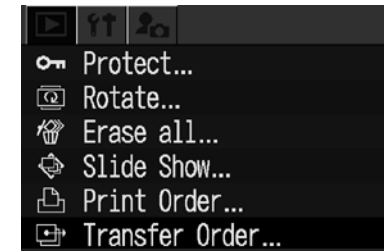

1 In the [ (Play)] menu, select [**Transfer Order**] and press the **SET** button.

- See *Selecting Menus and Settings* (p. 62).



2 Select [**Order**] using the  or  arrow and press the **SET** button.

- To cancel the image transfer settings, select [**Reset**] instead.

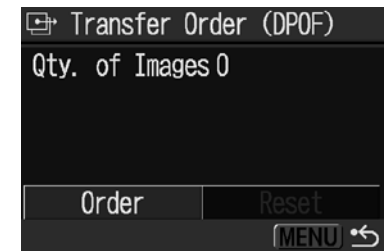

3 Select images for transferring.

Single Images

- Select an image using the ◀ or ▶ arrow and mark or remove marks from images using the ▲ or ▼ arrow. A check mark (✓) appears on the marked image.
- You can use the same procedures to select images in index playback (3 images). Turn the zoom lever toward 🔍 to switch between single image playback and index playback.



All the Images on a CF Card

- Turn the zoom lever toward 🔍 to switch to index playback (3 images).
- Press the **SET** button and select [Mark all] using the ▲ or ▼ arrow, then press the **SET** button again to select all the images.
- If you select [Clear all] instead of [Mark all], you can remove marks from all the images.



- You can select images using the ◀ or ▶ arrow and change the settings using the ▲ or ▼ arrow after [Mark all] or [Clear all] has been selected.

4 Press the MENU button.

The selection mode will turn off and the Transfer Order menu will reappear.



- ◆ Images are transferred in order from oldest to newest by the shooting date.
- ◆ A maximum of 998 images can be marked per CF card.

The following messages may appear on the LCD monitor (or viewfinder).

- For messages which may appear when a printer is connected, refer to the *Direct Print User Guide*.

Busy...	Image is being recorded to, or read from, CF card. Resetting all the camera and menu settings to default
No memory card	You attempted to shoot or play back images without a CF card installed.
Cannot record!	You attempted to shoot an image without a CF card installed.
Memory card error!	CF card has experienced an anomaly.
Memory card full	CF card is too full to accommodate more images or print settings.
Naming error!	The file could not be created because there is a file with the same name as the directory that the camera is attempting to create, or the highest possible file number has already been reached. In the Set up menu, please set [File No. Reset] to [On]. After you save all the images you wish to retain onto a computer, format the CF card (p. 18). Please note that formatting will erase all the existing images and other data.
Change the batteries	Battery charge is insufficient to operate the camera. Replace with new AA-size alkaline batteries or fully charged Canon AA-size NiMH batteries (p. 15) (be sure to replace all the batteries at the same time).
Overheated! Shutting down.	The internal temperature of the camera became too hot and the camera powered down.
No image	No images recorded on CF card.
Image too large	You attempted to play back an image larger than 4064 x 3048 pixels.
Incompatible JPEG format	You attempted to play back an incompatible JPEG file.
Corrupted data	You attempted to play back an image with corrupted data.
RAW	You attempted to play back an image recorded in an incompatible RAW format.
Cannot magnify!	You attempted to magnify a movie or an image that was photographed with another camera, recorded in a different format, or edited on a computer.

Cannot rotate	You attempted to rotate a movie or an image that was photographed with another camera, recorded in a different format, or edited on a computer.
Unidentified Image	You attempted to play back an image that was recorded in a special format (proprietary format used by the camera of another manufacturer, etc.) or a movie clip recorded by another camera.
Incompatible WAVE format	Cannot attach sound memos to the image because the image has some sound file recorded in an inappropriate format.
Protected!	You attempted to erase a protected image.
Too many marks	Too many images have been marked with print settings, transfer settings or slide show settings. Cannot process any more.
Unselectable image	You attempted to set the print settings for a non-JPEG file.
Cannot complete!	Couldn't save the print, transfer or slide show settings.
Cannot edit	Slide show settings file is corrupted.
Cannot register this image!	You attempted to register an image recorded with another camera or shot in the RAW format as a start-up image.



Troubleshooting

Problem	Cause	Solution
Camera will not operate	Power is not turned on.	Turn on the camera. → See <i>Turning the Power On/Off</i> (p. 19)
	CF card slot cover or battery cover opened.	Confirm that the CF card slot cover and battery cover are securely closed.
	Batteries are loaded in the wrong direction.	Reload the batteries in the correct direction.
	Insufficient battery voltage.	<ul style="list-style-type: none"> ● Replace with unused alkaline or fully recharged batteries (four AA-size batteries). ● Use the Compact Power Adapter.
	Batteries are not the right type.	Use only unused AA-size alkaline batteries or Canon AA-size NiMH batteries. For information about alkaline batteries, see <i>Proper Battery Handling</i> (p. 15).
	Poor contact between camera and battery terminals.	Wipe the terminals with a clean, dry cloth.
Camera will not record	Camera is in Playback or computer/printer connection mode.	<ul style="list-style-type: none"> ● Turn the mode lever to the left to switch to Shooting mode. ● During a computer or printer connection, disconnect the interface cable before switching the camera to Shooting mode.
	Flash is charging (Blinking ⚡ on LCD monitor/in viewfinder).	Wait until ⚡ stops blinking and lights steadily, signaling that the flash is charged, then press the shutter button.
	CF card full.	<ul style="list-style-type: none"> ● Insert a new CF card. ● If required, download the images to a computer and erase them from the CF card to make space.
	CF card not formatted correctly.	<ul style="list-style-type: none"> ● Format CF card. → See <i>Formatting a CF Card</i> (p. 18). ● If reformatting doesn't work, the CF card logic circuits may be damaged. Contact the nearest Canon Customer Support Help Desk.

Problem	Cause	Solution
Cannot play back	You attempted to play back images shot with another camera or images edited on a computer.	Computer images that cannot be played back will play back if they are added to the camera using the bundled software program ZoomBrowser EX or ImageBrowser.
	File name was changed with a computer or file location was changed.	Set the file name or location to the file format/structure of the camera. (See <i>About File and Folder Numbers</i> (p. 155).)
Lens will not retract	CF card slot cover or battery cover opened with camera on.	Close the CF card slot cover or battery cover, then turn off the camera.
	CF card slot cover or battery cover opened while camera was recording to CF card (warning signal).	Close the CF card slot cover or battery cover, then turn off the camera.
	Switched to Playback mode from Shooting mode.	The lens does not retract in this case. To make the lens retract, close the lens cover.
Batteries consumed quickly	Batteries are not the right type.	Use only unused AA-size alkaline batteries or Canon AA-size NiMH batteries. For information about alkaline batteries, see <i>Proper Battery Handling</i> (p. 15).
	The batteries are cold.	Battery performance deteriorates at low temperatures. If shooting in a cold area, keep the batteries warm (by placing them in an inner pocket, etc.) until ready to use them.
	Battery terminals are dirty.	Wipe them well with a dry cloth before use.
	The batteries have not been used for over a year.	If batteries are rechargeable: Performance should return to normal after several charging cycles.
	If rechargeable batteries: The batteries have lost their effectiveness.	Replace all 4 batteries with new ones.

Problem	Cause	Solution
If using rechargeable batteries: Batteries do not charge in separately sold battery charger.	Batteries were placed in the charger in the wrong direction.	Put batteries back into the charger in the correct direction.
	Poor electrical contact.	<ul style="list-style-type: none"> ● Be sure to set batteries firmly into the charger. ● Be sure that the power cord is firmly connected to the charger, and is firmly plugged in to the power outlet.
	Battery terminals are dirty.	Wipe them well with a dry cloth before charging.
	Battery life exceeded.	Replace all 4 batteries with new ones.
Image is blurred or out of focus	Camera moved.	<ul style="list-style-type: none"> ● Be careful not to move the camera when pressing the shutter button. ● Use a tripod at slow shutter speeds when the camera shake warning  appears. ● Turn the Image Stabilizer function on.
	Subject out of focal range.	Ensure that there is at least 50 cm (1.6 ft.) between the camera lens and subject.
	Subject is hard to focus on.	Use the focus lock or the manual focus to shoot the image. → See <i>Shooting Problem Subjects for the Autofocus</i> (p. 93).

Problem	Cause	Solution
Subject in recorded image is too dark	Insufficient light for shooting.	Set the built-in flash to on.
	Subject dark in comparison to the background.	<ul style="list-style-type: none"> ● Set the exposure compensation to a positive (+) setting. ● Use the AE lock or spot metering function. <ul style="list-style-type: none"> → See <i>Locking the Exposure Setting (AE Lock)</i> (p. 86) and <i>Switching between Light Metering Modes</i> (p. 76).
	Subject too far for flash to reach.	<ul style="list-style-type: none"> ● To use the built-in flash, shoot within the following ranges: Auto ISO: 1.0 to 4.2 m (3.3 to 14 ft.) of the subject at the maximum wide angle and within 1.0 to 3.0 m (3.3 to 9.8 ft.) at the maximum telephoto setting. ISO 100 equivalent: 1.0 to 3.8 m (3.3 to 12 ft.) of the subject at the maximum wide angle and within 1.0 to 2.5 m (3.3 to 8.2 ft.) at the maximum telephoto setting. ● Raise the ISO sensitivity and then shoot. <ul style="list-style-type: none"> → See <i>Changing the ISO Speed</i> (p. 81).
Subject recorded in image is too bright	Subject too close causing flash to be too bright.	Adjust the flash output with the flash exposure compensation function (p. 89).
	Subject bright in comparison to the background.	<ul style="list-style-type: none"> ● Set the exposure compensation to a negative (-) setting. ● Use the AE lock or spot metering function. <ul style="list-style-type: none"> → See <i>Locking the Exposure Setting (AE Lock)</i> (p. 86) and <i>Switching between Light Metering Modes</i> (p. 76).
	Light shining directly on subject or reflected off subject into camera.	Change the shooting angle.
	Flash set to On.	Set the flash to Auto or Off.
A vertical bar of light (red, purple) appears on the LCD monitor/in the viewfinder	Subject too bright	This is a normal occurrence in devices containing CCDs and does not constitute a malfunction. (This red bar of light will not be recorded when shooting still photos, but it will be recorded when shooting movies.)

Problem	Cause	Solution
White dots or white asterisks appear on the image	Light from the flash has reflected off dust particles or insects in the air. This occurs more frequently in the following conditions: ●When shooting at the wide angle end. ●When shooting with a high aperture value in the aperture-priority AE mode.	This is a phenomenon that occurs with digital cameras and does not constitute a malfunction.
Flash will not fire	Flash set to Off.	Set the flash to Auto or On.
Image not showing on TV	Incorrect video system setting.	Set the video system to the appropriate setting, NTSC or PAL, for your TV (p. 67).
	Shooting mode set to  (Stitch Assist).	The output will not appear on a TV monitor in  (Stitch Assist) mode. Shoot in a different mode.
CF card image reading is slow	Currently used CF card has been formatted in a different device.	Use a CF card formatted with this camera. → See <i>Formatting a CF Card</i> (p. 18).
Recording images on the CF card takes too long		

Using the Wireless Controller (Sold Separately)

Installing the Battery

Install the date battery (CR2025) into the Wireless Controller WL-DC100 (sold separately) before use.

Warning

Be particularly careful to keep the date batteries out of the reach of children. Seek medical assistance immediately if a child swallows a battery since corrosive battery fluids could damage the stomach or intestinal wall.

1 Place your fingertip on ① and press it in the direction of the arrow while placing another fingertip on ② and removing the battery holder.

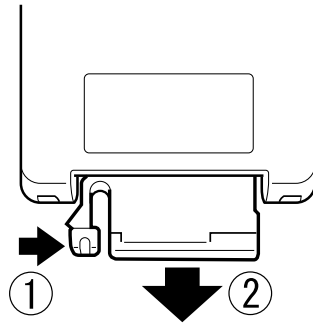

2 Place the date battery in the battery holder with the negative terminal (-) facing up. Then replace the battery holder into the wireless controller.

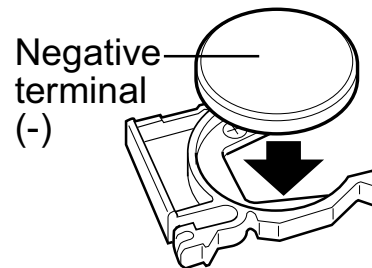

Removing the Battery

To remove the date battery, pull it in the direction of the arrow.

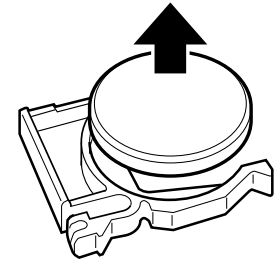

If you ever dispose of your camera, first remove the date battery for recycling according to the recycling system of your country.



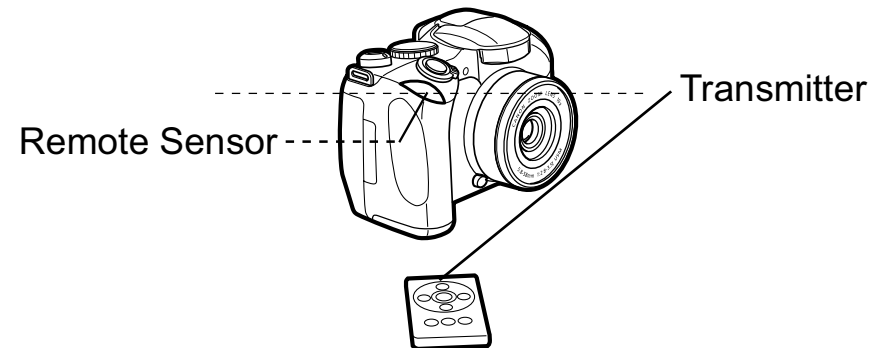

Shooting/Playback

The wireless controller can be used to shoot or play back. The wireless controller can be operated from an approximate distance of up to 5 m (16.4 ft.) from the front remote sensor.



Shooting

Press the  button on the camera until the  or  icon appears in the LCD monitor (or viewfinder), then shoot the image.

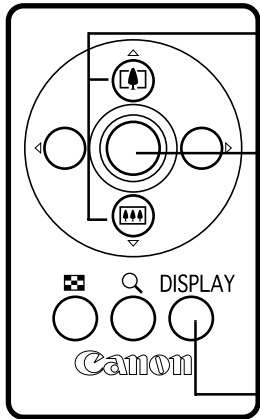

- ① Compose the image with the zoom ring.
 - ② Press the shutter button. The camera will shoot the image after the time set in [Wireless Delay] in the Rec. menu has elapsed (0 seconds, 2 seconds or 10 seconds).
- Each press of this button switches the information view mode between No Information and Information View.

Playback

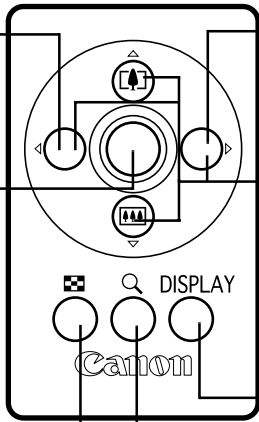
- 
- A line drawing of the camera's playback control panel. It shows a central area with four buttons: 'Previous Image' (left arrow), 'Next Image' (right arrow), 'Play Back Movies' (play button), and 'Magnified Area' (magnifying glass). Below these are three buttons labeled 'No Information', 'Information', and 'DISPLAY'. The 'No Information' button has a camera icon, the 'Information' button has a magnifying glass icon, and the 'DISPLAY' button has a camera icon. The Canon logo is at the bottom.
- Display the previous image
 - Display the next image
 - In magnified mode, these buttons move the magnified area around the image.
 - In index playback, these buttons move the image selection.
 - Each press of this button cycles the information view mode.
 - The display cycles between magnifications of approximately 2.5, 5 and 10.
 - Play back movies
 - Display images in sets of nine (index playback)



The operable range of the wireless controller will shorten under the following circumstances.

- When strong light strikes the camera.
- When the battery is weak.



The movie editing and printing functions are not available.

Using Conversion Lenses (Sold Separately)

Conversion Lens Adapter LA-DC52E and Lens Hood LH-DC20 are included in the separately sold Lens Adapter/Hood Kit LAH-DC10.

The camera supports use of the separately sold Wide Converter WC-DC52A and Tele-converter TC-DC52B. In order to attach any of these lenses, you also need to use the separately sold Conversion Lens Adapter LA-DC52E (included with LAH-DC10). When shooting in backlit conditions without the flash and at the wide angle end, the use of the lens hood is recommended to prevent external light from entering the lens.

Warning

- When attaching the wide converter or tele-converter, be sure to screw it on securely. If they come loose, they may fall from the lens adapter, posing risk of injury from shattered glass.
- Never look into the sun or into strong light through the wide converter or tele-converter as this can result in blindness or impairment of vision.



- If you use the built-in flash when shooting with the wide converter, the outer area of the recorded image (especially the bottom part of the image) will come out relatively dark.
- When using the wide converter, please set the camera to the wide angle end.
- When using the tele-converter, please set the focal length to the telephoto end. At other zoom settings, the image will appear as if its corners have been cut off.

Wide Converter WC-DC52A	This 52 mm-threaded magnifying conversion lens is for taking wide angle shots. The wide converter changes the focal length of the camera body's lens by a factor of 0.7.
Tele-converter TC-DC52B	This 52 mm-threaded diameter magnifying conversion lens is for taking telephoto shots. The lens changes the focal length of the camera body's lens by a factor of 1.6.



Filters and lens hoods cannot be attached to the wide converter and tele-converter lens.

Attaching a Lens/Lens Hood

1 Be sure that the camera is turned off. Press the ring release button and hold it down, turn the ring in the direction of the arrow and remove it.

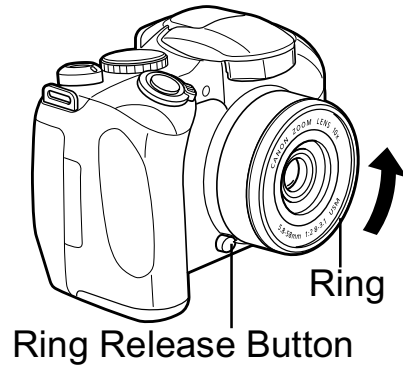

2 Align the ● marks on the conversion lens adapter and the ● mark on the camera, and turn the adapter in the direction of the arrows as far as the ▲ mark on the camera.

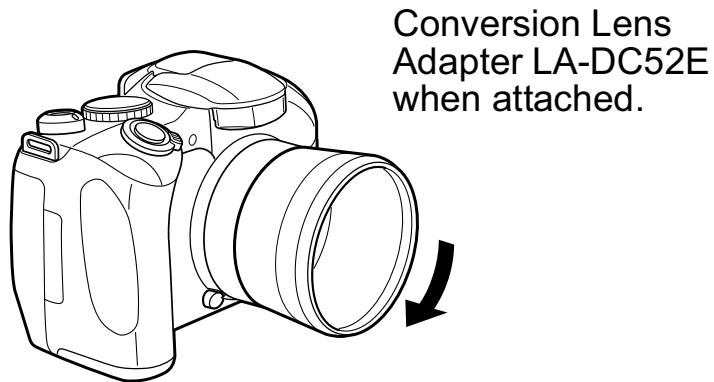

3 Set the lens or lens hood on the adapter, and attach it securely by turning it in the indicated direction.

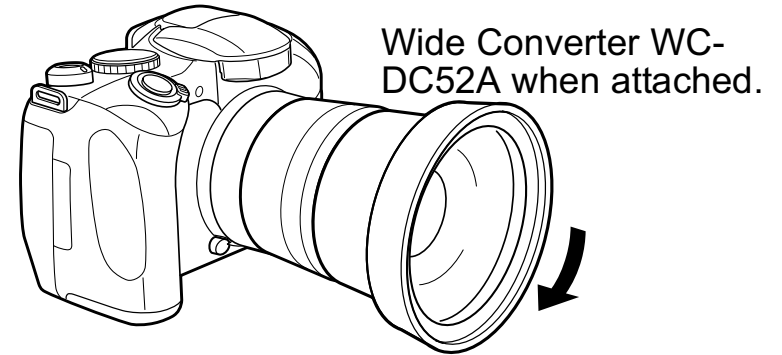



- You should not shoot images in  (Stitch Assist) mode when using these attachments. Although it is possible to select this mode on the camera, the PhotoStitch software will not be able to stitch the images together at the computer.
- To protect the conversion lens, hold the camera's lens with one hand and screw the conversion lens onto the camera with the other hand.
- Completely remove all dust and dirt from conversion lenses with a lens blower brush before use. The camera may focus on any dirt that remains.
- Be careful when handling the lenses so as not to get fingerprints on them.
- Once the lens adapter is screwed on the camera, it locks into place. When removing the wide converter or the tele-converter, do so while firmly pressing on the lens adapter with your hand to avoid damage to the lenses.

Using the Power Kits (Sold Separately)

Using Rechargeable Batteries (Battery and Charger Kit CBK4-200)

Included are the battery charger and four rechargeable AA-size NiMH (nickel metal hydride) batteries. Charge batteries as shown below.

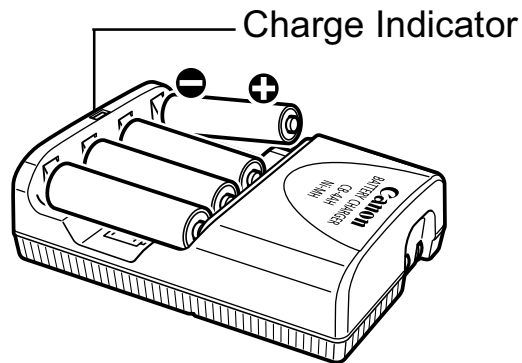

- The charge indicator blinks while charging, then remains lit when charging is finished.
- This charger can be used only to charge Canon AA-size NiMH batteries NB-2AH. Please do not attempt to charge NB-2AH batteries in any other type of charger.
- Never mix new batteries together with batteries that have been used in other devices.
- When recharging batteries from the camera, always recharge all four of them at the same time.

- All batteries you place in the charger should be at approximately the same charge state, and should have been purchased at the same time. Do not mix batteries with different purchase dates or different charge states.
- Do not attempt to recharge fully charged batteries, as doing so may reduce or impair battery performance. Also, do not charge batteries for more than 24 consecutive hours.
- Do not recharge batteries in enclosed areas that tend to retain heat.
- Repeatedly recharging batteries before they become fully depleted may cause batteries to lose capacity. Do not recharge the batteries until the LCD monitor displays the "Change the batteries" message.
- Wipe the battery terminals well with a dry cloth in the following situations, as the terminals may be soiled with oil from one's skin or other dirt:
 - if the battery usage time has considerably diminished
 - If the number of recordable images has considerably diminished

- When charging the batteries (insert and remove the batteries two or three times before charging)
- When charging completes in a matter of a few minutes (the battery charger indicator remains lit)
- You may not be able to fully charge the batteries due to their specifications right after purchase or after long periods of non-use. If this happens, use the batteries until their charge is depleted before charging them again. After doing this several times, battery performance will be restored.
- Since storing fully charged batteries for long periods of time (about 1 year) can shorten their lifecycle or affect performance, you are recommended to use the batteries in the camera until they are completely discharged and to store them at normal temperature (23 °C/73 °F) or less. If you do not use the batteries for long periods of time, charge them fully and discharge them fully in the camera at least once a year before returning them to storage.

- If battery usage time is considerably low despite their terminals being wiped and the battery charger's indicator remaining lit, it is possible that the batteries have reached the end of their lifespan. Switch to different, unused batteries. If you are purchasing new batteries, look for Canon's AA-size NiMH batteries NB4-200 (a NB-2AH four-battery set).
- Leaving batteries in the camera or charger may damage it causing battery leakage. Remove batteries from the camera or charger and store in a dry cool location when not in use.



- ◆ It takes approximately 250 minutes for the charger to fully recharge the batteries (as determined by testing at Canon facilities). Please do not charge batteries in areas where the temperature is outside the range of 0 to 35 °C (32 to 95 °F).
- ◆ Charging time varies according to ambient temperature and to the batteries' initial charge state.
- ◆ The battery charger may emit noise while charging. This is not a malfunction.
- ◆ Battery/Charger Kit CBK100 can also be used. Use Canon AA-size batteries NB-1AH with the charger included in the CBK100 kit.

Compact Power Adapter

You should use the separately sold Compact Power Adapter CA-PS700 when using the camera for long periods of continuous use or for connecting to a computer or printer.

1 Attach the power cord to the compact power adapter and plug it into a power outlet.

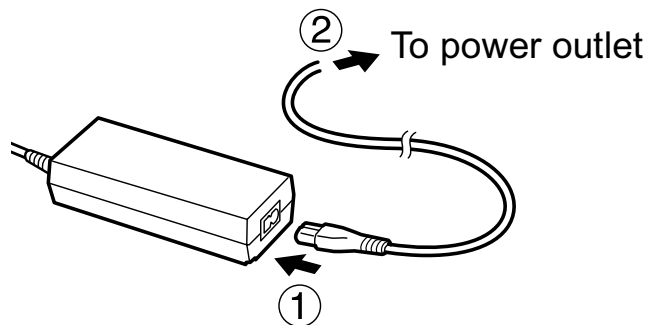

2 Open the terminal cover and connect the DC plug of the compact power adapter to the camera's DC IN terminal.

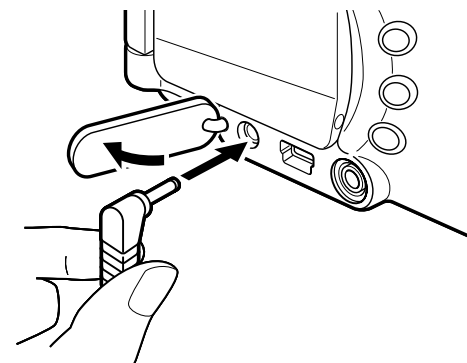

- Always disconnect and unplug the compact power adapter after use.



- Always turn the camera's power off (p. 19) before connecting or disconnecting the compact power adapter.
- Using any other device than Compact Power Adapter CA-PS700 may lead to camera and compact power adapter malfunctions.

Replacing the Date Battery

If the Set Date/Time menu appears when you turn on the camera power, the date battery charge is low and the date and time settings have been lost. Please replace the battery with a commercially available lithium coin battery (CR1220) with the following procedures.

Please note that the first date battery may appear to expire relatively quickly after you purchase the camera. This is because it is installed in the camera at the point of manufacture, not when you make the purchase.

Warning

Be particularly careful to keep the date batteries out of the reach of children. Seek medical assistance immediately if a child swallows a battery since corrosive battery fluids could damage the stomach or intestinal wall.

1 Turn off the power and slide the battery cover in the direction of the arrows.

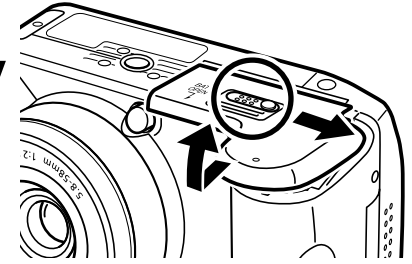

2 Remove the AA-size batteries, then pull out the battery holder by hooking your fingertip under the bottom of the battery holder edge.

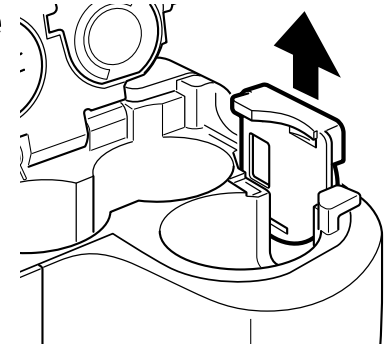

3 Remove the old date battery and place a new date battery into the date battery holder with the negative terminal (-) facing upward.

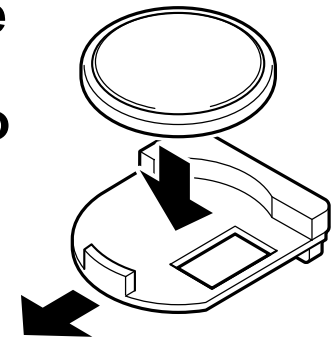

4 Replace the date battery holder, replace the AA-size batteries and close the battery cover.

Camera Care and Maintenance

Use the following procedures to clean the camera body, lens, viewfinder, LCD monitor and other parts.

Camera body	: Wipe the body clean with a soft cloth or eyeglass lens wiper.
Lens	: First use a lens blower brush to remove dust and dirt, then remove any remaining dirt by wiping the lens lightly with a soft cloth. ● Never use synthetic cleansers on the camera body or lens. If dirt remains, contact the nearest Canon Customer Support Help Desk as listed on the separate Canon Customer Support leaflet.
Viewfinder LCD Monitor	: Use a lens blower brush to remove dust and dirt. If necessary, gently wipe the viewfinder and LCD monitor with a soft cloth or an eyeglass lens wiper to remove stubborn dirt. ● Never rub or press forcefully on the LCD monitor or viewfinder. These actions may damage them or lead to other problems.



Never use thinners, benzene, synthetic cleansers or water to clean the camera. These substances may distort or damage the equipment.

Specifications

All data is based on Canon's testing standard. Subject to change without notice.

PowerShot S1 IS

Camera Effective Pixels	Approx. 3.2 million
Image Sensor	1/2.7 -inch CCD (Total number of pixels: Approx 3.3 million)
Lens	5.8 (W) – 58 (T) mm (35mm film equivalent: 38 - 380 mm) f/2.8 (W) – f/3.1 (T)
Digital Zoom	Approx. 3.2x (Up to approx. 32x in combination with the optical zoom)
Viewfinder	Color LCD viewfinder Picture coverage 100 %
LCD Monitor	1.5-inch, low-temperature polycrystalline silicon TFT color LCD (Picture coverage 100%)
AF System	TTL autofocus Focus lock and Manual focus are available Focusing frame: 1-point AF (any position is available)
Shooting Distance (from the front of the lens)	Normal AF: 10 cm (3.9 in.) – infinity (W)/ 93 cm (3.0 ft.) – infinity (T) Manual focus: 10 cm (3.9 in.) – infinity (W)/93 cm (3.0 ft.) – infinity (T)
Shutter	Mechanical shutter + electronic shutter
Shutter Speeds	15 – 1/2000 sec. 1.3 sec. or slower shutter speeds are available in Shutter-priority mode or Manual mode. Slow shutter speeds of 15 to 1.3 sec. or slower operate with noise reduction.
Light Metering System	Evaluative, Center-weighted average or Spot (Center or AF-point)
Exposure Control System	Program AE, Shutter-priority AE, Aperture-priority AE or Manual exposure control AE lock is available.
Exposure Compensation	± 2.0 stops in 1/3-stop increments Auto exposure bracketing (AEB) is available.
Sensitivity	Auto, ISO 50/100/200/400 equivalent

White Balance	TTL auto, pre-set (available settings: Daylight, Cloudy, Tungsten, Fluorescent, Fluorescent H or Flash) or custom
Built-in Flash	Auto*, on*, off * Red-eye reduction is available.
Flash Range	1.0 – 4.2 m (3.3 – 14 ft.) (W), 1.0 – 3.0 m (3.3 – 12 ft.) (T) (When sensitivity is set to ISO 100 equivalent.)
Flash Exposure Compensation	± 2.0 stops in 1/3-stop increments, FE lock, Slow synchro and 1st-curtain/2nd-curtain flash are available.
Shooting Modes	Auto Creative zone: Program, Shutter-speed priority, Aperture priority, Manual, Custom Image zone: Portrait, Landscape, Night scene, Fast shutter, Slow shutter. Stitch assist and Movie
Continuous Shooting	Approx. 1.7 shots/sec. (Large/Fine mode)
Interval Shooting	Shooting interval: approx. 1 – 60 min. (1-min. increments) Number of shots: 2 – 100 shots (Maximum number of shots varies according to CF card capacity.)
Self-timer	Activates shutter after an approx. 10-sec./approx. 2-sec. delay
Wireless Control	Shooting and playback are available (wireless controller is sold separately). When shooting, image is captured instantly/approx. 2-sec./approx. 10-sec. after shutter button is pressed.
PC-controlled Shooting	Available (USB connection only. Exclusive software program is included in the camera kit.)
Recording Media	CompactFlash™ (CF) card (Type I and Type II)
File Format	Design rule for camera file system and DPOF compliant

Image Recording Format	Still images: JPEG (Exif 2.2)*1 Movies: AVI (Image data: Motion JPEG; Audio data: WAVE (monaural))
Compression	Super fine, Fine, Normal
Number of Recording Pixels	Still images: Large: 2048 x 1536 pixels Medium 1: 1600 x 1200 pixels Medium 2: 1024 x 768 pixels Small: 640 x 480 pixels Movies: 640 x 480 pixels Fine 640 x 480 pixels 320 x 240 pixels 15 or 30 frames/second A maximum file size of 1 GB and a maximum of 1-hour recording are available in one movie shooting session
Frame Rate	15 frames/sec. or 30 frames/sec.
Audio Data	Sampling frequency: Approx. 22 kHz Quantization bit: 16 bit
Playback Modes	Single (histogram displayable), Index (9 thumbnail images), Magnified (approx. 10x (max.) in LCD monitor/viewfinder), Sound memos (recording/playback up to 60 sec.) or Slide show
Direct Print	<i>Canon Direct Print</i> and <i>Bubble Jet Direct</i> compatible, and <i>PictBridge</i> compliant
Display Languages	12 languages available for menus and messages (English, German, French, Dutch, Danish, Finnish, Italian, Norwegian, Swedish, Spanish, Chinese and Japanese)
My Camera Settings	The start-up image, start-up sound, shutter sound, operation sound and self-timer sound can be customized using the following methods: 1. Using the images and sounds recorded on a camera. 2. Using downloaded data from your computer using the supplied software.
Interface	USB (mini-B, PTP [Picture Transfer Protocol]) Audio/Video output (NTSC or PAL selectable, monaural audio)

Power Source	1. Four AA-size alkaline batteries (included in the camera kit) 2. Four AA-size rechargeable NiMH batteries (NB4-200) (sold separately) 3. Compact Power Adapter (CA-PS700) (sold separately)
Operating Temperature	0 – 40 °C (32 – 104 °F)
Operating Humidity	10 – 90 %
Dimensions	111 x 78.0 x 66.1 mm (4.4 x 3.1 x 2.6 in.) (excluding protrusions)
Weight	Approx. 370 g (13.1 oz.) (camera body only)

(W): Wide angle end
(T): Telephoto

*1 This digital camera supports Exif 2.2 (also called "Exif Print"). Exif Print is a standard for enhancing the communication between digital cameras and printers. By connecting to an Exif Print-compliant printer, the camera's image data at the time of shooting is used and optimized, yielding extremely high quality prints.

Battery Performance

	Number of Images Shot		Playback Time
	LCD Monitor on	Viewfinder on	
AA Alkaline Batteries (included with the camera)	Approx. 120	Approx. 125	Approx. 5 hours 30 min.
AA NiMH Battery (NB4-200)	Approx. 550	Approx. 570	Approx. 7 hours 30 min.

* The data above reflects standard Canon testing conditions. The actual figures will vary according to the shooting conditions and settings.

* Movie data is excluded.

<Test Conditions>

Shooting: Normal temperature (23 °C/73 °F), alternating wide angle and telephoto end shots at 20-second intervals with flash fired once every four shots and camera power turned off and on every eighth shot. CF card used. LCD monitor brightness set to factory default.















Playback: Normal temperature (23 °C/73 °F), continuous playback at one image per 3 seconds. CF card used. LCD monitor brightness set to factory default.



See *Proper Battery Handling* (p. 15).

CF Cards and Estimated Capacities (Recordable Images)

 With card included with the camera

			FC-32MH	FC-64M	FC-128M	FC-256MH	FC-512MSH
L (Large)	2048 x 1536 pixels		18	38	76	154	308
			33	68	137	276	552
			67	136	274	548	1096
M1 (Medium 1)	1600 x 1200 pixels		30	61	122	246	491
			54	109	219	440	879
			108	217	435	868	1736
M2 (Medium 2)	1024 x 768 pixels		53	107	215	431	855
			94	189	379	762	1524
			174	349	700	1390	2717
S (Small)	640 x 480 pixels		120	241	482	962	1893
			196	393	788	1553	3125
			337	676	1355	2720	5209
Movie*	640 x 480 pixels (Fine)		15 sec./30 sec.	30 sec./61 sec.	62 sec./124 sec.	125 sec./249 sec.	250 sec./499 sec.
	640 x 480 pixels		20 sec./42 sec.	42 sec./85 sec.	85 sec./170 sec.	172 sec./343 sec.	344 sec./686 sec.
	320 x 240 pixels		46 sec./91 sec.	92 sec./183 sec.	186 sec./368 sec.	374 sec./735 sec.	743 sec./1463 sec.

● These figures reflect standard shooting conditions established by Canon. Actual totals may vary according to the subject, shooting conditions and shooting mode.

● **L** (Large), **M1** (Medium 1), **M2** (Medium 2) and **S** (Small) show resolutions.

●  (Superfine),  (Fine) and  (Normal) indicate the relative compression ratio.

● Some CF cards are not sold in some regions.

* First setting is approximately 30 frames/second; second and third settings are approximately 15 frames/second.

Image File Sizes (Estimated)





Resolution		Compression		
				
L	2048 x 1536 pixels	1602 KB	893 KB	445 KB
M1	1600 x 1200 pixels	1002 KB	558 KB	278 KB
M2	1024 x 768 pixels	570 KB	320 KB	170 KB
S	640 x 480 pixels	249 KB	150 KB	84 KB

Image Quality		Frame Rate	
			
Movie	640 x 480 pixels (Fine)	1980 KB/sec.	990 KB/sec.
	640 x 480 pixels	1440 KB/sec.	720 KB/sec.
	320 x 240 pixels	660 KB/sec.	330 KB/sec.

Wireless Controller WL-DC100 (Sold Separately)

Power supply	: Date battery CR2025
Operating temperatures	: 0 – 40 °C (32 – 104 °F)
Dimensions	: 35 x 6.5 x 56.6 mm (1.4 x 0.3 x 2.2 in.)
Weight	: Approx. 10 g (0.4 oz.)

CompactFlash™ Card

Card slot type	: Type I
Dimensions	: 36.4 x 42.8 x 3.3 mm (1.4 x 1.7 x 0.1 in.)
Weight	: Approx. 10 g (0.4 oz.)

Compact Power Adapter CA-PS700 (Sold Separately)

Input voltage	: AC 100 – 240 V (50/60 Hz) 30 VA (100 V) – 40 VA (240 V)
Rated output	: DC 7.4 V/2.0 A
Operating Temperatures	: 0 – 40 °C (32 – 104 °F)
Dimensions	: 112 x 49 x 45 mm (4.4 x 1.9 x 1.8 in.)
Weight	: Approx. 186 g (6.6 oz.)

Battery Charger CB-4AH/CB-4AHE

(Included with the separately sold battery charger Kit CBK4-200)

Input voltage	: 100 - 240 V AC (50/60 Hz) 10W
Rated output	: 565 mA ^{*1} , 1275mA ^{*2}
Charging time	: Approx. 250 min. ^{*1} , Approx. 110 min. ^{*2}
Operating Temperatures	: 0 – 35 °C (32 – 95 °F)
Dimensions	: 65.0 x 105.0 x 27.5 mm (2.6 x 4.1 x 1.1 in.)
Weight	: Approx. 95 g (3.4 oz.)

*1 When using 4 NiMH NB-2AH batteries.

*2 When using 2 NiMH NB-2AH batteries, one at each end of the charger.

Wide Converter WC-DC52A (Sold Separately)

Magnification	: Approx. 0.7
Focal range	: 26.6 mm (35mm film equivalent)
Lens composition	: 3 elements in 3 groups
Shooting distance (from the front of the lens)	: 0 cm - infinity (0 in. - infinity)
Thread diameter	: 52 mm standard filter thread Conversion Lens Adapter LA-DC52E is required to attach this lens to the PowerShot S1 IS
Dimensions	: Diameter: 81.0 mm (3.2 in.) : Length: 46.0 mm (1.8 in.)
Weight	: Approx. 145 g (5.12 oz.)

Tele-converter TC-DC52B (Sold Separately)

Magnification	: Approx. 1.6
Focal range	: 608 mm (35mm film equivalent)
Lens composition	: 5 elements in 3 groups
Shooting distance (from the front of the lens)	: 2.15 m - infinity (7.1 ft. - infinity)
Thread diameter	: 52 mm standard filter thread Conversion Lens Adapter LA-DC52E is required to attach this lens to the PowerShot S1 IS
Dimensions	: Diameter: 69.6 mm (2.7 in.) : Length: 66.5 mm (2.6 in.)
Weight	: Approx. 145 g (5.12 oz.)

NiMH Battery NB-2AH

(Included with the separately sold NiMH NB4-200 or the Battery/Charger Kit CBK4-200)

Type	: Rechargeable nickel metal hydride battery
Nominal Voltage	: 1.2 V DC
Typical Capacity	: 2300 mAh (Lowest: 2150 mAh)
Cycle Life	: Approx. 300 times
Operating Temperature	: 0 – 35 °C (32 – 95 °F)
Dimensions	: Diameter: 14.5 mm (0.6 in.) : Length: 50 mm (2 in.)
Weight	: Approx. 29 g (1 oz.)

Conversion Lens Adapter LA-DC52E

(Included with the separately sold Lens Adapter/Hood Set LAH-DC10)

Thread Diameter	: 52 mm standard filter thread
Dimensions	: Diameter: 56.8 mm (2.2 in.) : Length: 34.5 mm (1.4 in.)
Weight	: Approx. 12 g (0.4 oz.)

Lens Hood LH-DC20

(Included with the separately sold Lens Adapter/Hood Set LAH-DC10)

Thread Diameter	: 52 mm standard filter thread
Dimensions	: Diameter: 73.8 mm (2.9 in.) : Length: 28.2 mm (1.1 in.)
Weight	: Approx. 15 g (0.5 oz.)

Photo Tips and Information

ISO Speed (p. 81)

The ISO speed is the numeric representation of the camera's sensitivity to light. The higher the ISO speed, the higher the sensitivity. A high ISO speed allows you to shoot images in dark indoor or outdoor conditions without a flash and also helps prevent blurred images due to camera shake. This is convenient when shooting images in places where flash photography is prohibited. The ISO speed setting makes full use of the available light, resulting in images that convey the feel of the place they were shot.



ISO 50 equivalent

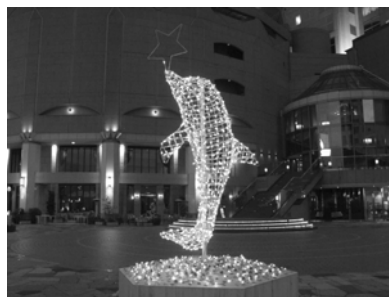

ISO 400 equivalent.

Tip for Using the Self-timer (p. 49)

Normally, the camera shakes a little when you press the shutter button.

Setting the self-timer to  delays the shutter release for two seconds and allows the camera to stop shaking, thus preventing a blurred image.

Even better results can be obtained by placing the camera on a stable surface or by using a tripod to shoot.

Histogram Function (p. 24)

The histogram is a graph that allows you to judge the brightness of the shot image. The greater the bias toward the left in the graph, the darker the image. The greater the bias toward the right, the brighter the image. If the image is too dark, adjust the exposure compensation to a positive value. Similarly, adjust the exposure compensation to a negative value if the image is too bright (p. 78).

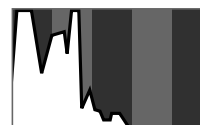

Dark Image



Balanced Image

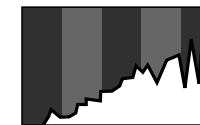

Bright Image

Managing Image Files (p. 110)

About File and Folder Numbers

Images are assigned file numbers from 0001 to 9900, and folders are assigned folder numbers from 100 to 998 (Folder numbers cannot contain 99 in the last two digits).

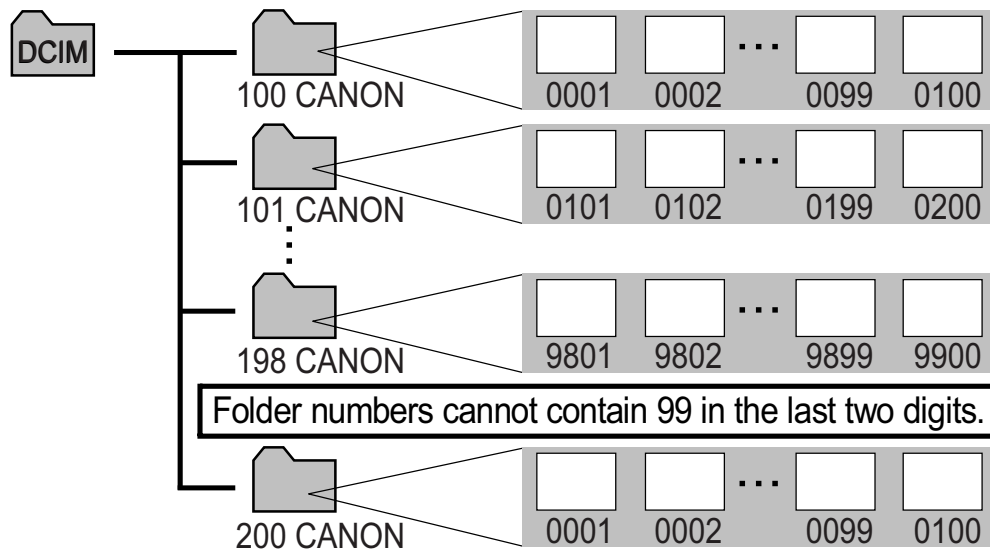

Folder File Capacity

Each folder usually contains up to 100 images. However, since images shot in Continuous mode and Stitch Assist mode are always saved into the same folder, a folder may contain more than 100 images. The number of images may also exceed 100 if a folder contains images copied from a computer or images shot with other cameras.

Please note, however, that the images in folders containing 2001 or more images cannot be played back in this camera.

How to Adjust the Exposure (p. 78)

This camera automatically adjusts the exposure to shoot images with the optimal brightness. However, recorded images may sometimes be brighter or darker than the actual image depending on the shooting conditions. If this happens, adjust the exposure compensation manually (p. 78).

Underexposure

The whole recorded image is dark, which makes white elements of the image appear gray. Shooting bright subjects or in backlit conditions may cause the image to be underexposed. Adjust the exposure compensation towards the + end.



Optimal Exposure



Overexposure

The whole recorded image is bright, which makes black elements of the image appear gray. Shooting dark subjects or in dark places may cause the image to be overexposed. Adjust the exposure compensation towards the - end.





Index

Numerics

- 1st-curtain90
- 2nd-curtain90

A



- Adjusting the Exposure78
- AE Lock86
- AEB Mode84
- AF Frame ()24, 75
- AF Lock Mode94
- AF Mode65
- Aperture value71
- Auto ()27
- Auto Power Down66, 107
- Auto Rotate Function67, 108
- Automated Playback (Slide Show)102

B

- B/W82
- Battery
 - Charge batteries140
 - Handling15
 - Status17

C

- CF Card
 - Formatting18
 - Handling17

- Color Effect ()82
- Compression32
- Continuous Shooting ()52
- Contrast color82
- Creative Zone71

D

- Date/Time21, 66
- Detailed Display24
- Digital Zoom50, 65
- DISPLAY12, 24
- Display Off66, 107
- Distance Units67
- DPOF
 - Print Order65, 121
 - Transfer Order66, 126

Drive Mode





-163







E





- Erase all65
- Erasing
 - Erasing All Images44
 - Erasing Images Individually43

F

- Fast Shutter ()45
- FE Lock87

File No. Reset	66	ISO Speed	81
File Numbers	110	J	
Flash	10, 34, 64	JUMP	12, 42
Adjustment Settings	88	L	
Sync	64	Landscape ()	45
Timing at which the Flash Fires	90	Language	23, 67
Focus	28, 93	LCD Brightness	66
Focus Lock	93	LCD Monitor	12, 24, 26
Focus-BKT Mode	85	Lens Cap	11
Format	66, 113	Lens Hood	137
Formatting	18	Light Metering Modes ()	65, 76
Frame rate	32, 56	M	
FUNC.	61	Magnifying Images ()	40
Function	12	Manual Exposure (M)	74
H		Manual Focus Mode	95
Histogram Function	24, 154	Menu	12, 62
I		My Camera Menu	67
Image Stabilizer	12, 29	Play Menu	65
Image Zone	45	Rec. Menu	64
Index Playback	41	Selecting Menus and Settings	62
Indicator	13	Set up Menu	66
Information View	24	MF	12
Intervalometer	65, 91	MF-Point Zoom	65
IS (Image Stabilizer)	12, 29	Microphone ()	12, 101

Mode Dial	13, 45, 71	Print Order	121
Mode Lever	12	Printing	119
Movie		Protect	65
Editing	57	R	
Recording ()	53	Red-Eye Reduction ()	10, 34, 36, 64
Viewing	57	Remote Sensor	10
Mute	66	Resetting the File Numbers	110
My Camera Settings	111, 112	Resetting the Settings to Default	68
N		Resolution	32
Neck Strap	11	Reverse Disp.	65
Night Scene ()	45	Review	65
O		Rotate	65
Omni selector	12	Rotating Images	100
Operation Sound	67, 111, 112	S	
Operation Vol.	66	Saturation	82
Overexposure Warning	26	Save Settings ()	65
P		Saving Custom Settings	98
Playback	100	Self-timer ()	12, 49, 64
Playback Mode	20, 24	Self-timer Sound	67, 111, 112
Playback Vol.	66	Selftimer Vol.	66
Portrait ()	45	Sharpness	82
Power On/Off	19	Shooting	
Power Saving Function	66, 107	Movie	53
Power/Mode Indicator	13	Shooting Mode	20, 24

Shortcut ()	12, 65, 69	Telephoto ()	12, 27
Shutter		Terminal Cover	12
Button	12	Transfer Order	126
Pressing	28	Transmission settings	
Sound	28, 67, 111, 112	Image Transmission settings	126
Speed	71	V	
Volume	66	Video System	67
Slide Show	65, 102	Viewfinder	12, 26
Play Time	105	Viewing	
Repeat	105	Images on a TV Set	118
Selecting Images	103	Volume	66
Starting	102	W	
Slow Shutter ()	45	White Balance (WB)	79
Slow Synchro	36, 64	Wide Angle ()	12, 27
Sound Memos	101	Wide Converter	137
Speaker	12	Wireless Controller	135
Standard Display	24	Wireless Delay	64
Start-up Image	19, 67, 111, 112	Z	
Start-up Sound	19, 67, 111, 112	Zoom	12, 27, 40, 50
Start-up Vol.	66		
Stitch Assist ()	45, 47		
T			
Tally Lamp	10, 65		
Tele-converter	137		

MEMO

MEMO

MEMO

MEMO

MEMO

Functions Available in Each Shooting Mode

This chart shows the functions available in each shooting mode. You can shoot with the settings saved in the **C** mode (p. 98).

											P	Tv	Av	M	Ref. Page
Resolution (Stills)	Large	L	○*	○*	○*	○*	○*	○*	△*	—	○*	○*	○*	○*	p. 32
	Medium 1	M1	○	○	○	○	○	○	△	—	○	○	○	○	
	Medium 2	M2	○	○	○	○	○	○	△	—	○	○	○	○	
	Small	S	○	○	○	○	○	○	△	—	○	○	○	○	
Resolution (Movies)	640 x 480 pixels (Fine)		—	—	—	—	—	—	—	○	—	—	—	—	p. 56
	640 x 480 pixels		—	—	—	—	—	—	—	○*	—	—	—	—	
	320 x 240 pixels		—	—	—	—	—	—	—	○	—	—	—	—	
Compression	Superfine		○	○	○	○	○	○	△	—	○	○	○	○	p. 34
	Fine		○*	○*	○*	○*	○*	○*	△*	—	○*	○*	○*	○*	
	Normal		○	○	○	○	○	○	△	—	○	○	○	○	
Frame Rate	30 Frames/sec.		—	—	—	—	—	—	—	○*	—	—	—	—	p. 35
	15 Frames/sec.		—	—	—	—	—	—	—	○	—	—	—	—	
Flash	Auto		○*	○*	○	○*	○*	○	—	—	○	—	—	—	p. 36
	On		—	○	○	○	○	○	△	—	○	○	○	○	
	Off		○	○	○*	○	○	○*	△*	—	○*	○*	○*	○*	
Red-eye Reduction			○	○	○	○	○	○	△	—	○	○	○	○	p. 35
Slow Synchro	On		—	—	○	○	—	○	△*	—	○	—	○	—	p. 36
	Off		○	○	—	—	○	—	△	—	○*	○	○*	○	

										P	Tv	Av	M	Ref. Page
Flash Adjust	On	○	○	○	○	○	○	○	○	○	○*	○*	—	p. 88
	Off	—	—	—	—	—	—	—	—	—	○	○	○	
Flash Sync	1st-curtain	○	○	○	○	○	—	○	—	○*	○*	○*	○*	p. 90
	2nd-curtain	—	—	—	—	—	○	—	—	○	○	○	○	
Flash Pop-up	On	○	○	○	○	○	○	○	—	○*	○*	○*	○*	p. 34
	Off	—	—	—	—	—	—	—	—	○	○	○	○	
Drive Mode	Single Shot	○*	○*	○*	○*	○*	○*	○*	○*	○*	○*	○*	○*	—
	Standard Continuous Mode	—	○	○	○	○	○	—	—	○	○	○	○	p. 52
	10-second Self-timer	○	○	○	○	○	○	○	○	○	○	○	○	p. 49
	2-second Self-timer	○	○	○	○	○	○	○	○	○	○	○	○	
Intervalometer		—	—	—	—	—	—	—	—	○	○	○	○	p. 91
AF Frame	Center Point	○	○	○	○	○	○	○	○	○*	○*	○*	○*	p. 75
	Manual	—	—	—	—	—	—	—	—	○	○	○	○	
AF Lock		—	○	○	○	○	○	○	○	○	○	○	○	p. 86
Manual Focus		—	○	○	○	○	○	○	—	○	○	○	○	p. 95
Digital Zoom	On	○	○	○	○	○	○	—	—	○	○	○	○	p. 50
	Off	○*	○*	○*	○*	○*	○*	—	—	○*	○*	○*	○*	

										P	Tv	Av	M	Ref. Page
Exposure Compensation		-	○	○	○	○	○	△	△ ⁽²⁾	○	○	○	-	p. 78
Light Metering System	Evaluative Metering	○	○	○	○	○	○	○	○	○*	○*	○*	○*	p. 76
	Center-Weighted Averaging	-	-	-	-	-	-	-	-	○	○	○	○	
	Spot Metering	-	-	-	-	-	-	-	-	○	○	○	○	
	Center	-	-	-	-	-	-	-	-	○*	○*	○*	○*	
	AF Point	-	-	-	-	-	-	-	-	○	○	○	○	
AE Lock/FE Lock		-	-	-	-	-	-	-	○ ⁽³⁾	○	○	○	-	p. 86, 87
Bracket	AEB	-	-	-	-	-	-	-	-	○	○	○	-	p. 84
	Focus-BKT	-	-	-	-	-	-	-	-	○ ⁽¹⁾	○ ⁽¹⁾	○ ⁽¹⁾	○ ⁽¹⁾	p. 85
White Balance ⁽⁴⁾ WB		- ⁽⁵⁾	○	○	○	○	○	△	○ ⁽⁶⁾	○	○	○	○	p. 79
Photo Effect		-	○	○	○	○	○	△	○	○	○	○	○	p. 82
Contrast/Sharpness/Saturation		-	-	-	-	○	○	-	-	○	○	○	○	
Focus Settings	Continuous	○*	○*	○*	○*	○	○	△*	○	○*	○*	○*	○*	p. 97
	Single	○	○	○	○	○	○	△	-	○	○	○	○	
ISO Speed ISO		- ⁽⁷⁾	- ⁽⁷⁾	- ⁽⁷⁾	- ⁽⁷⁾	- ⁽⁷⁾	- ⁽⁷⁾	- ⁽⁷⁾	- ⁽⁷⁾	○	○	○	○ ⁽⁸⁾	p. 81
Auto Rotate	On	○*	○*	○*	○*	○*	○*	△*	-	○*	○*	○*	○*	p. 108
	Off	○	○	○	○	○	○	△	○	○	○	○	○	